

TECHNICAL MANUAL
OPERATOR'S MANUAL

This copy is a reprint which includes current pages from Change 1.

WATER PURIFICATION UNIT,
REVERSE OSMOSIS,
600 GPH TRAILER MOUNTED,
FLATBED CARGO,
5 TON 4 WHEEL TANDEM
ROWPU MODEL WPES-1
(4610-01-295-2720)
AND
600 GPH SKID MOUNTED
(4610-01-300-0918)
MODEL WPES-3
(4610-01-295-2719)

TABLE OF
CONTENTS i

EQUIPMENT
DESCRIPTION 1-2

OPERATING
INSTRUCTIONS 2-1

PREVENTIVE
MAINTENANCE 2-17

LUBRICATION
INSTRUCTIONS 3-1

TROUBLESHOOTING
PROCEDURES 3-1

MAINTENANCE
PROCEDURES 3-16

SUBJECT INDEX
INDEX-1

Approved for public release; distribution is unlimited.

** This manual, together with TM 10-4610-215-10/TM 08580A-10/1 and
TM 10-4610-239-10/TM 08580B-10/1, supersedes TM 5-4610-215-10/
TM 08580A-10/1, 15 May 1987, including all changes.*

CHANGE

HEADQUARTERS,
DEPARTMENTS OF THE ARMY, AIR FORCE
AND HEADQUARTERS, U.S. MARINE CORPS
WASHINGTON, D.C., 16 October 1996

NO. 2

Operator's Manual

**WATER PURIFICATION UNIT, REVERSE OSMOSIS,
600 GPH TRAILER MOUNTED, FLATBED CARGO,
5 TON 4 WHEEL TANDEM ROWPU
MODEL WPES-1 (4610-01-295-2720)
AND
600 GPH SKID MOUNTED ROWPU
MODEL WPES-2 (4610-01-300-0918) (Air Force)
MODEL WPES-3 (4610-01-295-2719) (Marine Corps)**

DISTRIBUTION STATEMENT A: Approved for public release; distribution is unlimited.

TM 10-4610-240-10/TM 08580C-10/1/T.O. 40W4-13-21, 5 March 1991, is changed as follows:

1. Remove and insert pages as indicated below. New or changed text material is indicated by a vertical bar in the margin. An illustration change is indicated by a miniature pointing hand.

Remove pages

i and ii
1-1 and 1-2
1-5 and 1-6
1-19 /(1-20 blank)
2-43 through 2-46
2-77 and 2-78
2-97 and 2-98
B-1 through B-16
D-1 through D-4

Insert pages

i and ii
1-1 and 1-2
1-5 and 1-6
1-19 /(1-20 blank)
2-43 through 2-46
2-77 and 2-78
2-97 and 2-98
B-1 through B-16
D-1 through D-4

2. Retain this sheet in front of manual for reference purposes.

By Order of the Secretaries of the Army, Air Force, and Navy (Including the Marine Corps):

Official:

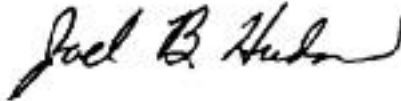

*Administrative Assistant to the
Secretary of the Army*
02574

DENNIS J. REIMER
*General, United States Army
Chief of Staff*

RONALD R. FOGELMAN
*General, USAF
Chief of Staff*

HENRY VICCELLIO, JR.
*General, USAF
Commander, Air Force Materiel Command*

J.E. BUFFINGTON
*Rear Admiral, CEC, US Navy
Commander
Navy Facilities Engineering
Command*

D.R. BLOOMER
*Colonel, USMC
Director, Program Support
Marine Corps Systems Command*

DISTRIBUTION:

To be distributed in accordance with DA Form 12-25-E, block no. 4486, requirements for TM 10-4610-240-10.

CHANGE

HEADQUARTERS,
DEPARTMENTS OF THE ARMY, AIR FORCE
AND HEADQUARTERS U.S. MARINE CORPS
WASHINGTON, D.C., 1 February 1994

NO. 1

Operator's Manual

WATER PURIFICATION UNIT,
REVERSE OSMOSIS,
600 GPH TRAILER MOUNTED,
FLATBED CARGO,
5 TON 4 WHEEL TANDEM
ROWPU MODEL WPES-1
(4610-01-295-2720)
AND
600 GPH SKID MOUNTED
ROWPU MODEL WPES-2
(4610-01-300-0918)
MODEL WPES-3
(4610-01-295-2719)

DISTRIBUTION STATEMENT A: Approved for public release; distribution is unlimited

TM 10-4610-240-10/T.O. 40W4-13-21/TM 08580C-10/1, 5 March 1991, is changed as follows:

1. Remove and insert pages as indicated below. New or changed text material is indicated by a vertical bar in the margin. An illustration change is indicated by a miniature pointing hand.

Remove pages

Insert pages

D-1 through D-4

D-1 through D-4

2. Retain this sheet in front of manual for reference purposes.

By Order of the Secretaries of the Army, Air Force, and Navy (Including the Marine Corps):

Official:

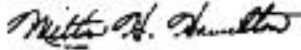

MILTON H. HAMILTON
*Administrative Assistant to the
Secretary of the Army*
06343

GORDON R. SULLIVAN
*General, United States Army
Chief of Staff*

Official:

RONALD W. YATES
*General, USAF
Commander, Air Force Materiel Command*

MERRILL A. McPEAK,
*General, USAF
Chief of Staff*

D.R. BLOOMER
*Colonel, USMC
Director, Program Support
Marine Corps Systems Command*

DAVID E. BOTTORFF
*Rear Admiral, CEC, US Navy
Commander
Navy Facilities Engineering
Command*

DISTRIBUTION:

To be distributed in accordance with DA Form 12-25-E, block no. 4486, requirements for
TM 10-4610-240-10.

WARNING
ELECTRICAL HIGH VOLTAGE CAN KILL YOU

Electrical high voltage cannot be seen but it can kill you. Electricity is unlike most other dangerous things you can come in contact with because it gives no warning and no symptoms to be wary of. Its effect is immediate. It can kill you, render you unconscious, or severely burn you. To ensure your safety and that of other maintenance personnel, always observe the following precautions:

DO NOT perform any maintenance on electrical equipment unless all power is removed.

BE CERTAIN that there is someone assisting you who can remove power immediately.

ALWAYS place POWER OFF warning tags on power supply switches so that no one will apply power while you are performing maintenance.

ALWAYS make sure the unit is properly grounded.

FOR ARTIFICIAL RESPIRATION, REFER TO FM 21-11

WARNING
DANGEROUS CHEMICALS CAN KILL YOU

The chemicals used for operation in the ROWPU can kill you. Breathing some of the chemicals used in the ROWPU system can cause severe headaches, dizziness, loss of muscular control, a sleepy feeling and coma. Brain damage, eye injury, severe skin damage, or death can result from heavy exposure. The chemicals alone or in a mixture can be very dangerous without good air movement. These precautions must be followed to ensure safety when handling or mixing chemicals:

ALWAYS wear protective clothing while handling dangerous chemicals.

NEVER get too close to or breathe dangerous chemicals.

ALWAYS make certain that a good clean water supply is available to flush away any chemicals that might come in contact with the body.

BE alert at all times during operation for chemical odors and exposure symptoms. If either is present, IMMEDIATELY VENTILATE personnel compartments. If symptoms persist, remove personnel to fresh air.

WARNING
NOISE

Operating level of this generator can cause hearing damage. Ear protectors, as recommended by the medical or safety officer, and supplied in the component boxes, must be worn when working near this set.

WARNING

Generator sets must not be operated in enclosed areas unless exhaust discharge is properly vented to the outside. Be alert at all times during operation for odors and exposure symptoms.

a /(b blank)

TECHNICAL MANUAL

HEADQUARTERS.
DEPARTMENTS OF THE ARMY ND AIR FORCE
AND HEADQUARTERS. U.S. MARINE CORPS,
WASHINGTON, D.C., 5 March 1991

NO. 10-4610-240-10

Operator's Manual

**WATER PURIFICATION UNIT, REVERSE OSMOSIS
600 GPH TRAILER MOUNTED, FLATBED CARGO,
5 TON 4 WHEEL TANDEM ROWPU
MODEL WPES-1 (4610-01-295-2720)
AND
600 GPH SKID MOUNTED ROWPU
MODEL WPES-2 (4610-01-300-0918) (Air Force)
MODEL WPES-3 (4610-01-295-2719) (Marine Corps)**

DISTRIBUTION STATEMENT A: Approved for public release; distribution is unlimited.

REPORTING ERRORS AND RECOMMENDING IMPROVEMENTS

ARMY

You can help improve this manual. If you find any mistakes, or if you know of a way to improve these procedures, please let us know. Mail your letter or DA Form 2028 (Recommended Changes to Publications and Blank Forms), or DA Form 2028-2 located in the back of this manual directly to: Commander, US Army Aviation and Troop Command, ATTN: AMSAT-I-MP, 4300 Goodfellow Blvd., St. Louis, MO 63120-1798. You may also submit your recommended changes by E-mail directly to <mpmt%avma28@st-louis-emh7.army.mil>. A reply will be furnished directly to you. Instructions for sending an electronic 2028 may be found at the back of this manual immediately preceding the hard copy 2028.

AIR FORCE

Reports by U. S. Air Force units should be submitted on AFTO Form 22 (Technical Order Publication Improvement Report and Rely) and forwarded to the address prescribed above for the Army. An information copy of the prepared AFTO Form 22 shall be furnished to SA-ALC/TILDP, Kelly AFB, TX 78241-6421.

MARINE CORPS

Commander, ATTN: (Code 850), Marine Corps Logistics Bases, 814 Radford Blvd., Albany, GA 31704-1128.

TABLE OF CONTENTS

CHAPTER 1	INTRODUCTION	PAGE
Section I	General Information	1-1
Section II	Equipment Description	1-2
Section III	Technical Principles of Operation	1-17
CHAPTER 2	OPERATING INSTRUCTIONS	
Section I	Description and Use of Operator's Controls and Indicators	2-1
Section II	Preventive Maintenance Checks and Services	2-17
Section III	Operation Under Usual Conditions	2-30
Section IV	Operation Under Unusual Conditions	2-91

* This manual, together with TM 10-4610-215-10/TM 08580A-10/1 and TM 10-4610-239-10/TM 08580B-10/1, supersedes TM 5-4610-215-10/TM 08580A.10/1, 15 May 1987, including all changes.

TABLE OF CONTENTS cont.

PAGE

CHAPTER 3	MAINTENANCE INSTRUCTIONS	
Section I	Lubrication Instructions	3-1
Section II	Troubleshooting Procedures	3-1
Section III	Maintenance Procedures	3-16
CHAPTER 4	MAINTENANCE OF AUXILIARY EQUIPMENT	
Section I	Generator Set	4-1
APPENDIX A	REFERENCES	A-1
APPENDIX B	COMPONENTS OF END ITEM AND BASIC ISSUE ITEM LIST	B-1
APPENDIX C	ADDITIONAL AUTHORIZATION LIST	C-1
APPENDIX D	EXPENDABLE/DURABLE SUPPLIES AND MATERIALS LIST	D-1
INDEX		INDEX-1

LIST OF ILLUSTRATIONS

Figure	Title	Page
1-1	Reverse Osmosis Water Purification Unit (ROWPU) (Army)	1-0
1-2	Reverse Osmosis Water Purification Unit (ROWPU) (MC and AF)	1-0
1-3	Top View of ROWPU With Operating Equipment Stored (Army).....	1-3
1-4	Top View of ROWPU With Operating Equipment Stored (MC and AF)	1-4
1-5	Top view of ROWPU With Pumps (Army)	1-5
1-6	Top view of ROWPU With Pumps (MC and AF)	1-6
1-7	Top View of ROWPU With Operating Equipment Removed (Army).....	1-7
1-8	Top View of ROWPU With Operating Equipment Removed (MC and AF)	1-8
1-9	Control Panel Side of ROWPU	1-9
1-10	Hoses and Storage Boxes.....	1-10
1-11	Raw Water and Backwash Pumps	1-11
1-12	Distribution Pump	1-11
1-13	ROWPU-Generator Removed (Rear View)	1-12
1-14	ROWPU Flatbed Trailer and Frame (Army)	1-14
1-15	Water Processing Block Diagram	1-19
2-1	Electrical Plug	2-1
2-2	Air Hose Glad-Hand Connectors.....	2-1
2-3	Water Meter	2-3
2-4	Controls and Indicators: Control Panel (sheet 1 of 3)	2-4
2-4	Controls and Indicators: Control Panel (sheet 2 of 3)	2-5
2-4	Controls and Indicators: Control Panel (sheet 3 of 3)	2-6
2-5	Vent Vessels Valve.....	2-11
2-6	Vent Product Water Valve	2-11
2-7	Chemical Feed Pump Controls	2-12
2-8	Gate Valves.....	2-12
2-9	Drain Valves	2-13
2-10	Chemical Feed Pump Valves	2-13
2-11	Total Dissolved Solids (TDS) Meter	2-14
2-12	Turgidity Tube	2-14
2-13	Color Comparator Kit.....	2-15
2-14	Backwash Timer	2-16
2-15	Site Diagram	2-30
2-16	Preparation For Use (Sheet 1 of 4) (Army Model)	2-31
2-16	Preparation For Use (Sheet 2 of 4) (Army Model)	2-32
2-16	Preparation For Use (Sheet 3 of 4) (Army Model)	2-33
2-16	Preparation For Use (Sheet 4 of 4) (Army Model)	2-34
2-17	Unfold Safety Step (Army)	2-35
2-18	Canvas Cover Tied Back.....	2-35
2-19	Top View of ROWPU	2-36
2-20	Cross Braces, Cargo Straps, Ratchets	2-36
2-21	Top View of ROWPU and Overpack.....	2-38
2-22	Storage Box No. 2	2-38
2-23	Storage Box No. 3	2-38
2-24	Outboard Pumps	2-39
2-25	Total Dissolved Solids Mete.....	2-39
2-26	TDS Monitor location	2-40
2-27	Typical Field Installation	2-41
2-28	Typical Water Tank Installation.....	2-42
2-29	Raw Water System	2-43
2-30	Backwash Pump and Strainer.....	2-43
2-31	Backwash Water System.....	2-44

LIST OF ILLUSTRATIONS cont.

Figure	Title	Page
2-32	Product Water System	2-45
2-33	Waste Water System	2-46
2-34	Wood Paddles and Chemical Tube Assemblies	2-46
2-35	Tubes Attached to Chemical Feed Pumps	2-47
2-36	Ground Rod in Stowed Position	2-49
2-37	Junction Box	2-50
2-38	Drain Valves (During Operation)	2-50
2-39	Vent Product Water Valve	2-51
2-40	Vent Valves	2-51
2-41	R.O. Vessels Sample Valves (Typical)	2-51
2-42	Backwash Valve	2-52
2-43	Product Flow Valve	2-52
2-44	Control Box Switches	2-53
2-45	Element Cleaning Switch	2-53
2-46	Raw Water Pump (Prime, Drain and Vent Valve)	2-54
2-47	High Pressure Relief Valve and Rupture Disc	2-55
2-48	Emergency Stop Button	2-56
2-49	High/Low Pressure Lamps	2-56
2-50	Switches (Pump Controls)	2-57
2-51	Output Hose Raw Water Pump No	2-58
2-52	Chemical Feed Pump Start Switch	2-58
2-53	Control Knobs	2-59
2-54	Multimedia Filter Vent Valve	2-60
2-55	Booster Pump Switch	2-61
2-56	Cartridge Filter Vent Valve	2-61
2-57	Controls, R.O. Pump	2-62
2-58	R.O. Pump and Motor	2-62
2-59	Pulse Dampener Vent Valve	2-63
2-60	R.O. Vessels	2-63
2-61	Turgidity Tube	2-64
2-62	Drain Valves	2-64
2-63	Nameplates	2-65
2-64	R.O. Pressure and Product Water Flow Gages	2-66
2-65	Product Water Flow Gages and Pressure	2-66
2-66	Brine Water Shutoff Valve	2-68
2-67	R.O. Pump Low Pressure Lamp	2-68
2-68	R.O. Pump High Pressure Lamp	2-68
2-69	Distribution Pump Switch	2-69
2-70	Solid State Timer	2-70
2-71	Backwash Water Tank	2-73
2-72	Product Water Flow Indicator	2-75
2-73	R.O. Pressure Gage	2-75
2-74	Shutdown Position of Control Panel Switches and Valves	2-76
2-75	Total Dissolved Solids (TDS) Meter	2-78
2-76	Preparation for Movement (Sheet 1 of 7) (Army Model)	2-84
2-76	Preparation for Movement (Sheet 2 of 7) (Army Model)	2-85
2-76	Preparation for Movement (Sheet 3 of 7) (Army Model)	2-86
2-76	Preparation for Movement (Sheet 4 of 7) (Army Model)	2-87
2-76	Preparation for Movement (Sheet 5 of 7) (Army Model)	2-88
2-76	Preparation for Movement (Sheet 6 of 7) (Army Model)	2-89
2-76	Preparation for Movement (Sheet 7 of 7) (Army Model)	2-90

LIST OF ILLUSTRATIONS cont.

Figure	Title	Page
2-77	Resetting Locked Spring Brake (Army)	2-92
2-78	Nuclear and Chemical Filter Installation	2-97
3-1	R.O. Vessel End Cap Assembly Removal.....	3-17
3-2	R.O. Vessel Element Puller	3-18
3-3	R.O. Vessel element Puller Assembly	3-18
3-4	Pulling Element From R.O. Vessel	3-19
3-5	R.O. Vessel (Exploded View)	3-20
3-6	Element Installation	3-21
3-7	Element Installation	3-21
3-8	Element Replacement.	3-22
3-9	Element Replacement	3-22
3-10	Cartridge Filter Assembly	3-24
3-11	Cartridge Filter End Plate (Nut Tightening Sequence).....	3-25
3-12	Backwash Pump Strainer	3-26
3-13	R.O. Pump Rupture Disc and Holder	3-27
3-14	Total Dissolved Solids (TDS) Meter Battery Replacement	3-28
3-15	Switch Indicator Lamp Replacement.....	3-29
3-16	Panel Light Replacement.....	3-30

LIST OF TABLES

Table	Title	Page
2-1	Water Processing Controls and Indicators	2-7
2-2	(Army) Operator/Crew Preventive Maintenance Checks and Services (Trailer).....	2-18
2-3	Operator/Crew Preventive Maintenance Checks and Services (Unit)	2-20
2-4	Gage Readings, Normal and Trouble-point	2-67
2-5	Shutdown Position of Valve or Switch.....	2-77
3-1	(Army) Troubleshooting (Trailer)	3-1
3-2	Troubleshooting (ROWPU).....	3-5

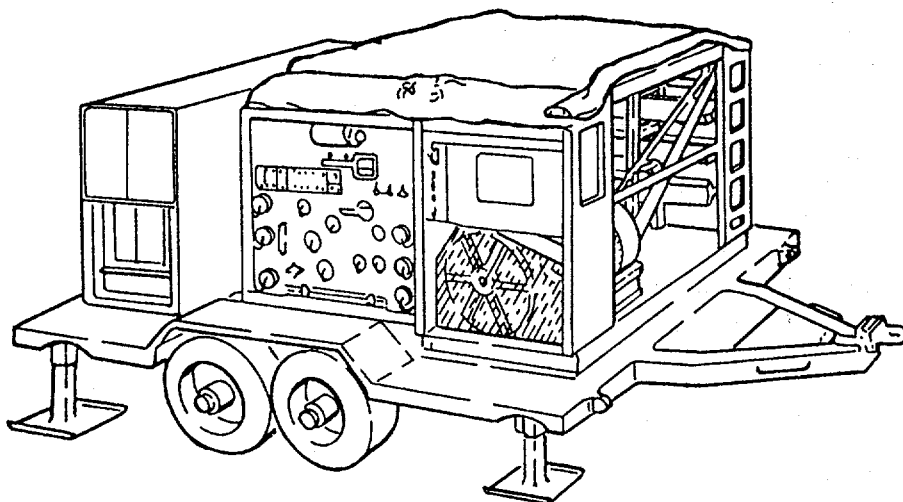

FIGURE 1-1. REVERSE OSMOSIS WATER PURIFICATION UNIT (ROWPU) (ARMY)

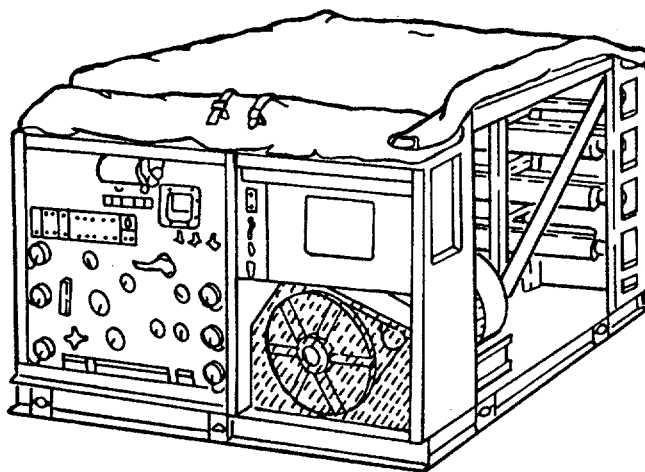

FIGURE 1-2. REVERSE OSMOSIS WATER PURIFICATION UNIT (ROWPU) (MC AND AF)

CHAPTER 1

INTRODUCTION

Section I.	General Information
Section II.	Equipment Description
Section III.	Technical Principles of Operation

Section I. GENERAL INFORMATION

	Page
Scope	1-1
Maintenance forms and records	1-1
Hand Receipt Manuals	1-1
Reporting Equipment Improvement Recommendations (EIRs)	1-2

1-1. SCOPE.

This operator's manual describes the Operating and Operator's Maintenance Procedures for the 600 Gallon Per Hour (GPH) Reverse Osmosis Water Purification Unit (ROWPU). It should be noted that although a complete 600 GPH Reverse Osmosis Water Purification Equipment Set is described herein, certain components are not issued under the National Stock Number NSN 4610-01-295-2720 (ARMY) but are authorized under their own TOE Line Item Numbers and are listed in the Department of the Army Supply Catalog SC 4610-97-CL-E16 which describes the entire 600 GPH ROWPU Set. NSN 4610-01-295-2719 is the Marine Corps (MC) ROWPU designation. Air Force (AF) units are designated by NSN 4610-01-300-0918.

NOTE

Paragraphs not designated Army, Marine Corps (MC), or Air Force (AF) are applicable to all configurations. The following model numbers identify units covered in this manual.

- WPES-1 - Army Trailer Mounted Unit (ARMY)
- WPES-2 - Air Force Skid mounted unit (AF)
- WPES-3 - Marine Corps Skid mounted unit (MC)

1-2. MAINTENANCE FORMS AND RECORDS.

Good maintenance records must be kept. Department of Army forms and procedures used for equipment maintenance will be those prescribed by DA PAM 738-750, The Army Maintenance Management System (TAMMS). Marine Corps personnel refer to TM 4700-15/1 for forms and records procedures. Air Force personnel refer to MAJCOM and local directives.

1-3. HAND RECEIPT. (ARMY).

A companion hand receipt technical manual has been issued with the ROWPU to aid in accounting for all of the end-item related equipment. The hand receipt manual is numbered with TM number of this manual (TM 10-4610-240-10) followed by "-HR". Hand Receipt Manual TM 10-4610-240-10-HR contains reprinted hand receipts for Components of End Item (COEI), Basic Issue Items (BII), and Additional Authorization List (AAL): items. Additional HR manuals may be obtained from the U.S. Army Adjutant General Publications Center, ATTN: AGDL-OD, 2800 Eastern Blvd., Baltimore, MD 21220, in accordance with the procedures in DA PAM 25-30.

1-4. REPORTING EQUIPMENT IMPROVEMENT RECOMMENDATIONS (EIRS).

If your ROWPU needs improvement, let us know. Send us an EIR. You, the user, are the only one who can tell us what you do not like about your equipment. Let us know why you do not like the design. Tell us why a procedure is hard to perform. Put it on an SF-368 (Quality Deficiency Report). Mail it to us at:

Commander
US Army Aviation and Troop Command
ATTN: AMSAT-I-MDO
4300 Goodfellow Blvd.
St. Louis, MO 63120-1798

Marine Corps personnel submit EIR's in accordance with MCO 1650-17.
Air Force personnel submit AFTO Form 22 in accordance with T.O. 00-5-1.

Section II. EQUIPMENT DESCRIPTION

	Page
Equipment Characteristics, Capabilities and Features	1-2
Location and Description of Major Component	1-3
Equipment Data	1-13
Piping Identification	1-17

1-5. EQUIPMENT CHARACTERISTICS, CAPABILITIES, AND FEATURES.

a. Characteristics. The ROWPU is a mobile water purifying unit needing a 30 KW power source, that supplies drinking water for troops in the field. (See figure 1-1 (ARMY) and figure 1-2 (MC and AF)).

b. Capabilities and Features.

(1) Flow systems within the ROWPU process raw water to make it drinkable. Special pumps, controlled by a built-in control panel, move the water through the ROWPU to produce as much as 10 gallons (37.8 liters) of drinking water per minute. This water is stored in a collapsible tank. The ROWPU can be transported by rail, road, or air.

(2) (ARMY) The flatbed cargo trailer and frame is designed to provide a mobile platform for the ROWPU. The trailer, when being transported by road, is towed by a towing vehicle through a lunette/pintle hookup. The trailer has four square leveling jacks with swivels, one on each corner, and is equipped with a spare wheel and tire carrier. The trailer incorporates service brakes which are air actuated and operated from the towing vehicle through an integral set of hoses. The trailer brake system also includes emergency and automatic parking brake functions that are activated when the air hoses are disconnected from the towing vehicle. An air tank is installed for the purpose of reserving air for this system when the trailer is disconnected from the towing vehicle. A 24-volt electrical system, consisting of a composite blackout-spotlight assembly, and tail light assembly, is installed on the trailer, Power is supplied through a cable connected to the electrical system of the towing vehicle. The frame houses the ROWPU and is capable of being separated from the trailer and transported or air lifted as an independent unit.

(3) The ARMY, AIR FORCE (AF) and MARINE CORPS (MC) units are essentially the same except that the MC and AF ROWPU units are mounted on a skid and do not incorporate a generator. The AF and the MC units have four forklift pockets.

1-6. LOCATION AND DESCRIPTION OF MAJOR COMPONENTS.

The Army ROWPU is 18 feet (5.5 meters) long, 8 feet (2.4 meters) high, and 8 feet (2.4 meters) wide. It weighs about 8 1/2 tons (7.71 metric tons), including the generator set. Figure 1-3 shows the ROWPU from the top with its canvas cover removed. Take a close look at how all the necessary operating equipment is stored on the trailer for transport and shipment.

The Marine Corps and Air Force ROWPUs are 9.5 (2.9 meters) long, 5.6 feet (1.7 meters) high and 6.9 feet (2.1 meters) wide. They weigh about 3.65 tons (3 metric tons). Figure 1-4 shows top view of ROWPU with the canvas cover removed and equipment stored.

a. To provide room for all operating components, material is stored in layers (figures 1-3 and 1-4) The top layer consists of rolled-up (suction) hoses on top of three folded water tanks. Stored between the tanks is a sledge hammer and a collapsed telescopic aluminum paddle. Next to the tanks is a stack of five plastic pails. On the same side of the ROWPU you will find two storage boxes fastened with a strap under the tanks. The boxes contain various chemicals, tools, and installation items. Nine sections of suction hose are stored on the side of the frame.

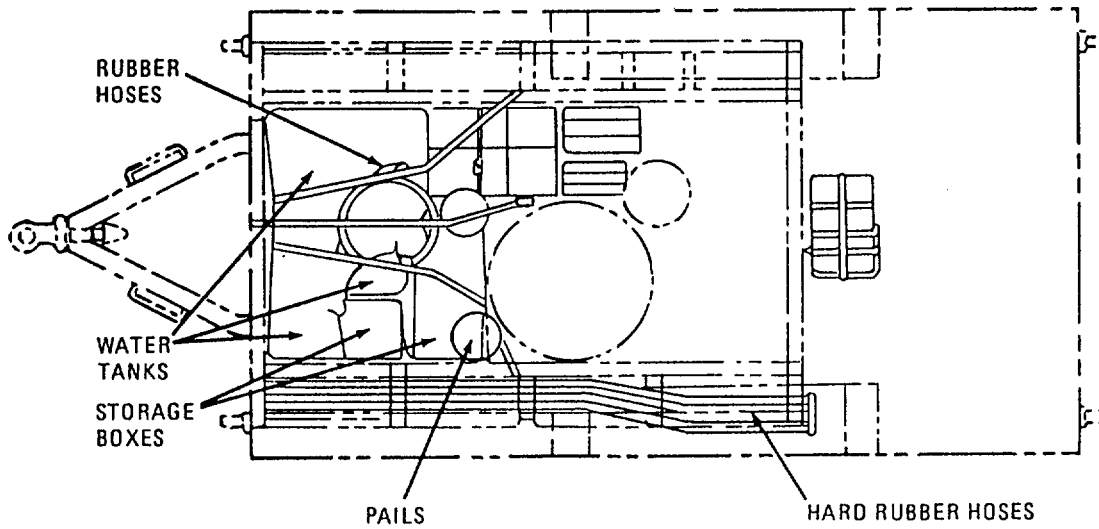

FIGURE 1-3. TOP VIEW OF ROWPU WITH OPERATING EQUIPMENT STORED (ARMY).

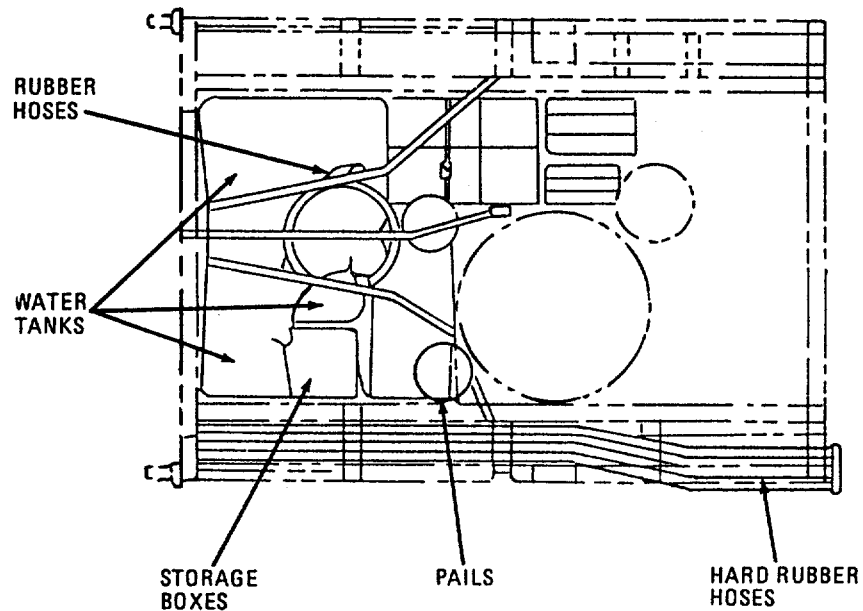

FIGURE 1-4. TOP VIEW OF ROWPU WITH OPERATING EQUIPMENT STORED (MC AND AF).

b. Second Layer. In the second layer you will find two raw water pumps and a backwash pump (figures 1-5 and 1-6). The pumps are covered with canvas and strapped down. (ARMY) A distribution pump is located at the rear of the unit next to the generator, but is not shown here (AF and MC are packed separately). Army ROWPU includes a portable step strapped down with distribution pump. On the right side are 1-1/2 inch and 2-inch diameter discharge (canvas) hoses, rolled-up. A raw water float is in the center of the ROWPU next to one nuclear, one biological, chemical (NBC) cylinders. Figures 1-7 and 1-8 show ROWPU with operating equipment removed.

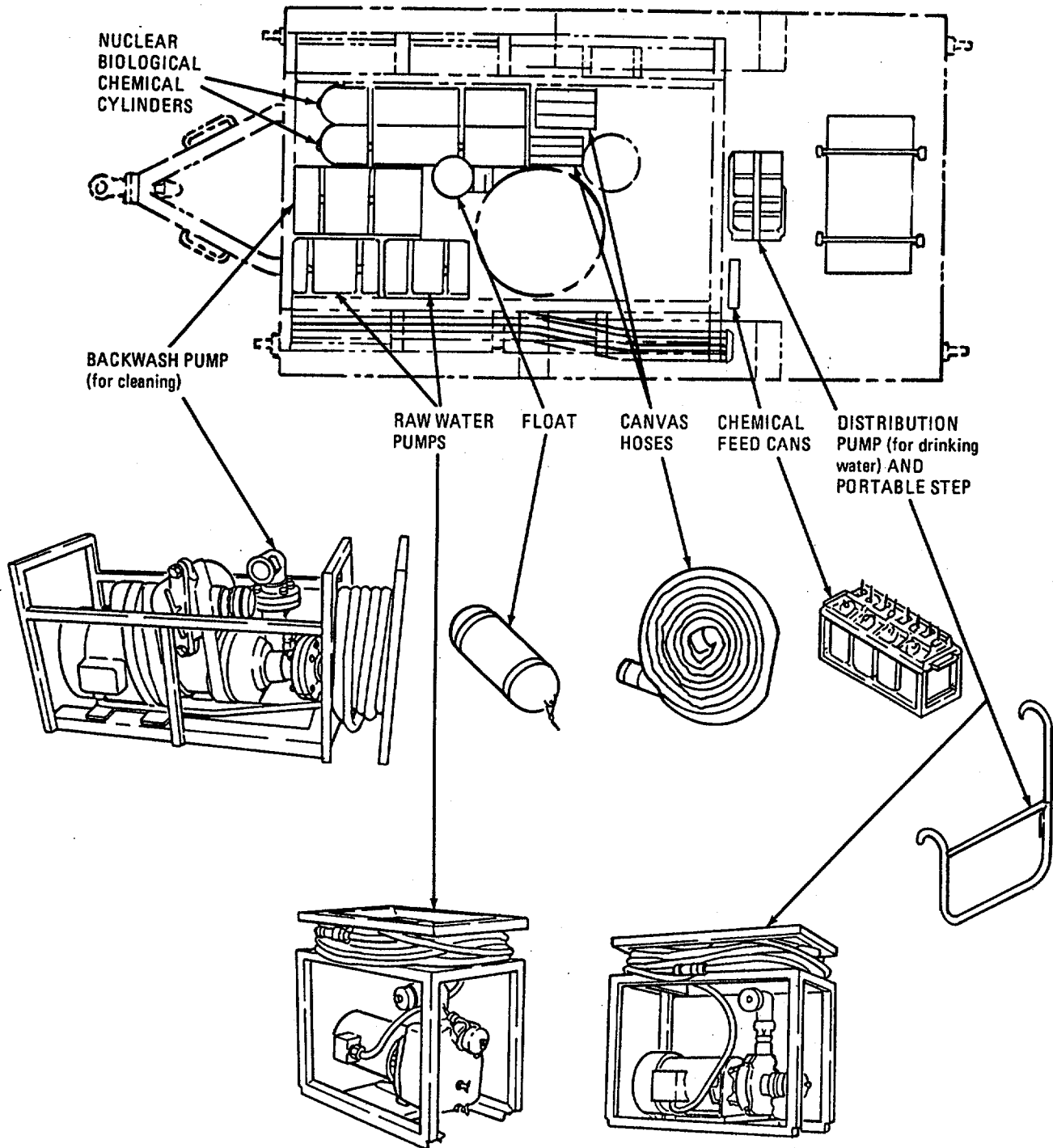

FIGURE 1-5. TOP VIEW OF ROWPU WITH PUMPS (ARMY).

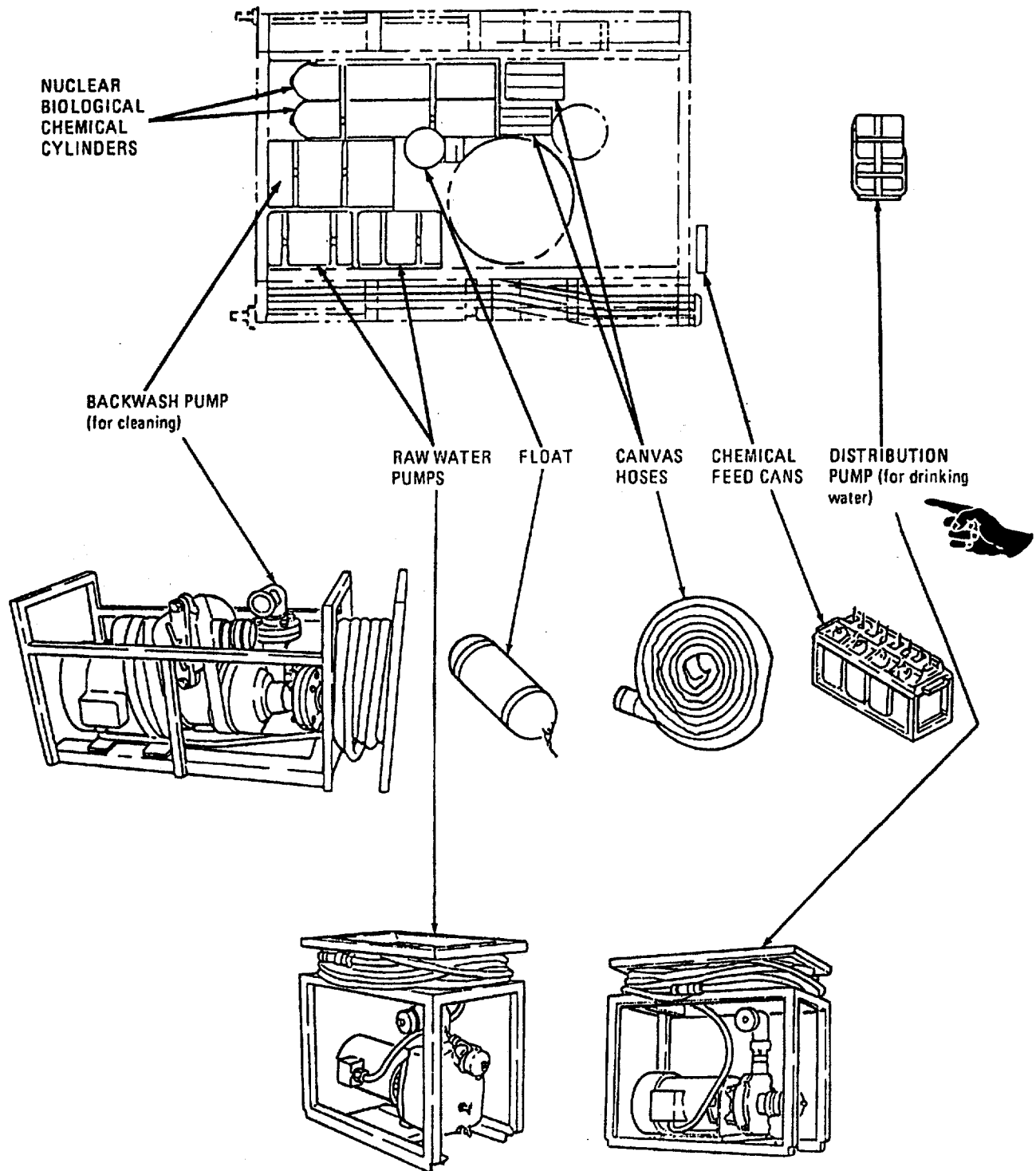

FIGURE 1-6. TOP VIEW OF ROWPU WITH PUMPS (MC and AF).

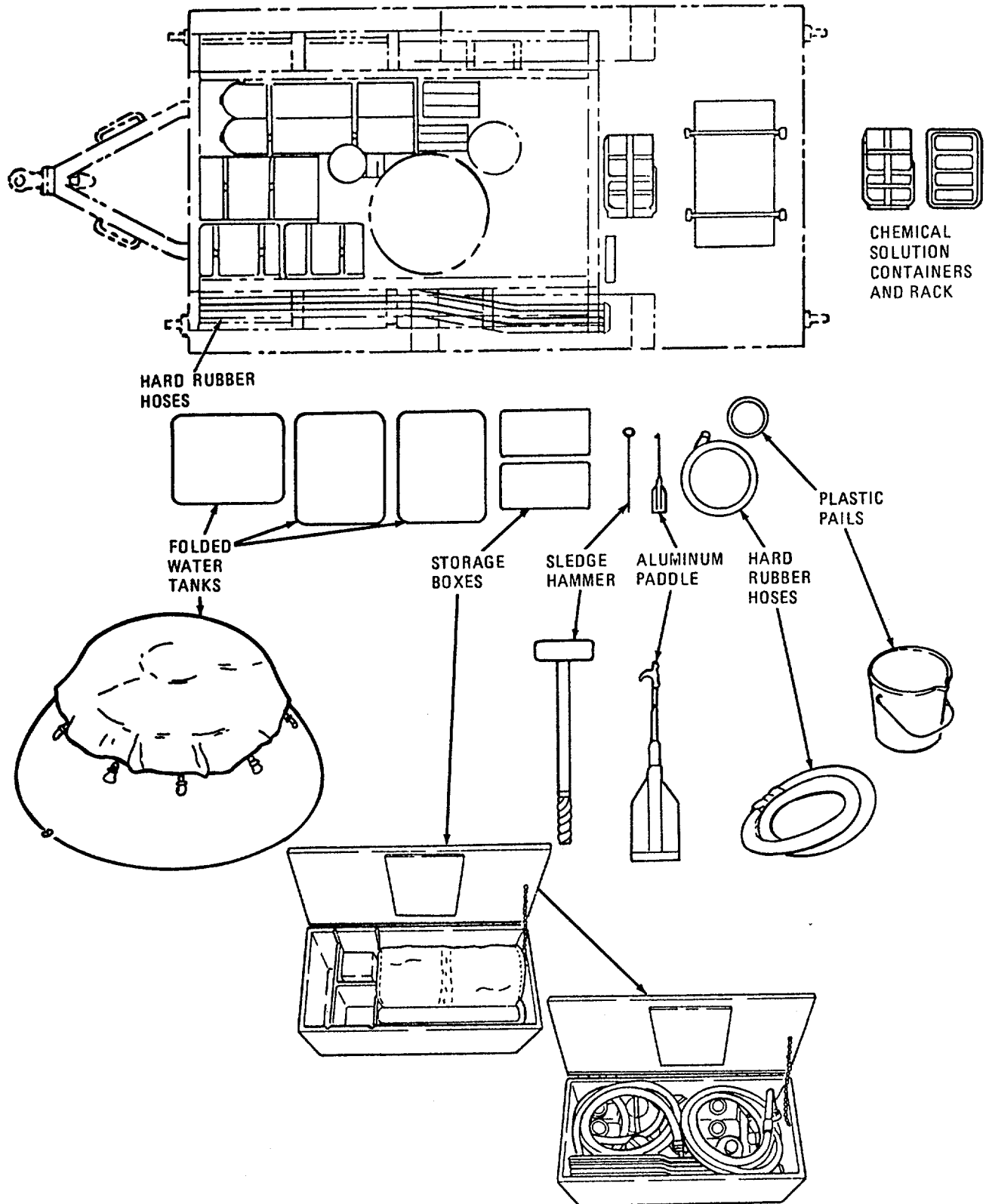

FIGURE 1-7. TOP VIEW OF ROWPU WITH OPERATING EQUIPMENT REMOVED (ARMY).

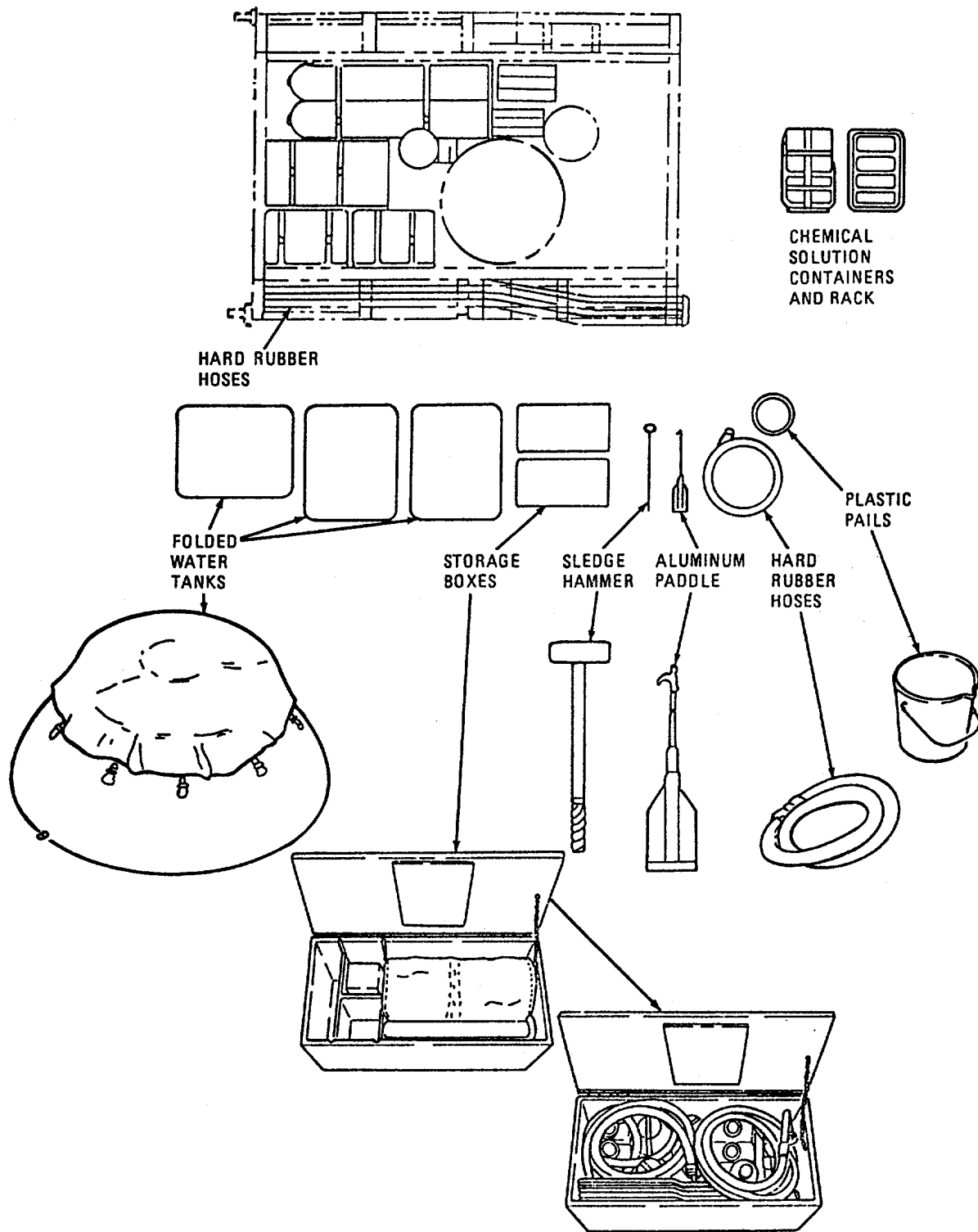

FIGURE 1-8. TOP VIEW OF ROWPU WITH OPERATING EQUIPMENT REMOVED (MC and AF).

c. External Components. Figure 1-9 identifies the following parts:

- CANVAS COVERS (1). Protect unit from weather. Rolled up and strapped during normal operation.
- CROSS BRACES (2). Give strength to ROWPU frame during shipment. Can be removed to get at equipment.
- R.O. PRESSURE VESSELS (3). Four vessels which house eight reverse osmosis elements that reduce total dissolved solids from filtered water to produce drinking water.
- R.O. PUMP (4). Applies high pressure to raw filtered water in R.O. pressure vessels.
- CONTROL PANEL (5). Panel with meters, gauges, switches, valves, and hose connections.
- GROUND ROD (6). Driven into ground and attached to ROWPU to keep operators from getting electric shocks from power source or static electricity.
- CONTROL BOX (7). Panel with switches to control all pumping and panel lighting.
- GENERATOR SET (8). (ARMY) Provides electricity needed to operate ROWPU.
- JUNCTION BOX (9). Contains circuit breakers, overload heaters, motor starters, relays, etc.

NOTE

MC and AF Models are skid-mounted with no generator.

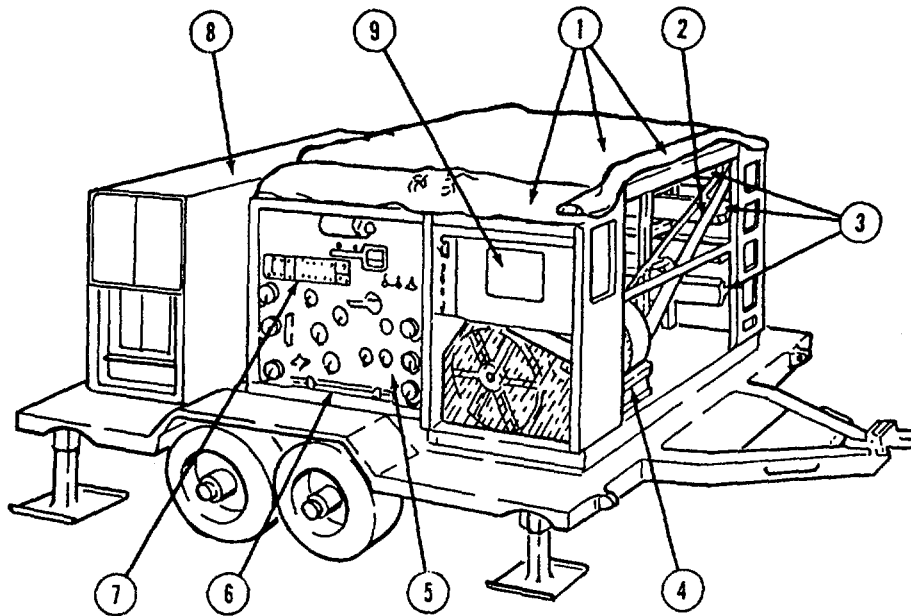

FIGURE 1-9. CONTROL PANEL SIDE OF ROWPU

LEGEND

- | | | |
|--------------------------|------------------|------------------|
| 1. CANVAS COVER | 4. R.O. PUMP | 7. CONTROL BOX |
| 2. CROSS BRACES | 5. CONTROL PANEL | 8. GENERATOR SET |
| 3. R.O. PRESSURE VESSELS | 6. GROUND ROD | 9. JUNCTION BOX |

d. Accessory Components. After you remove the equipment shown in figures 1-10, 1-11, and 1-12, the inside of the ROWPU will be visible.

NOTE

Only two storage boxes exist. They are labeled Storage Boxes 2 and 3.

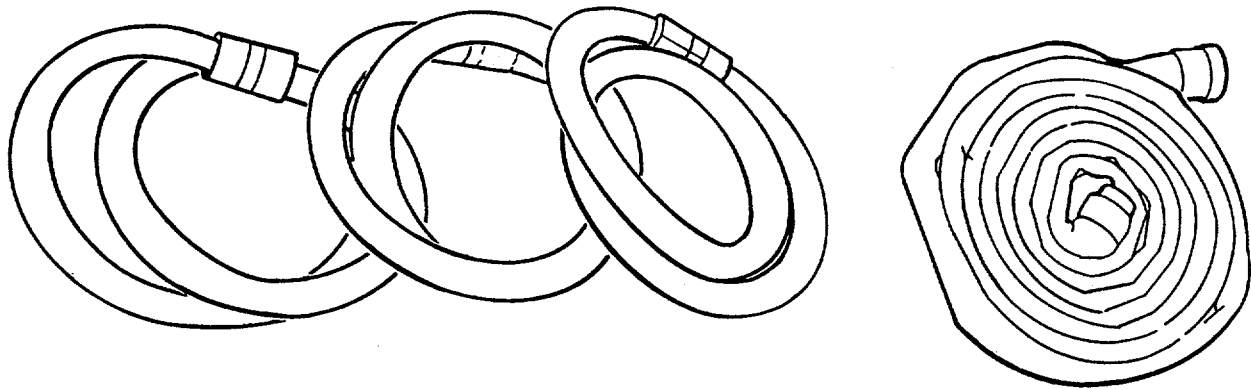

SUCTION HOSES HARD RUBBER

DISCHARGE HOSES (CANVAS)

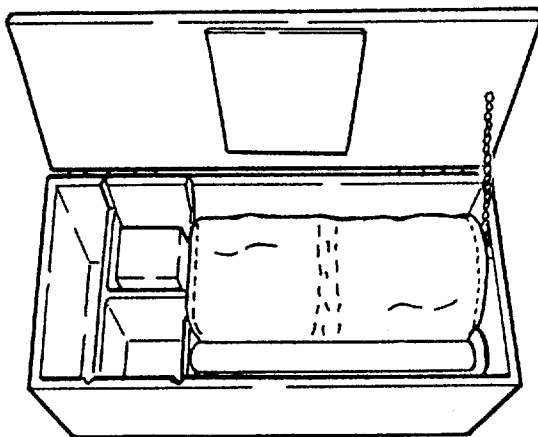

STORAGE BOX NO. 2

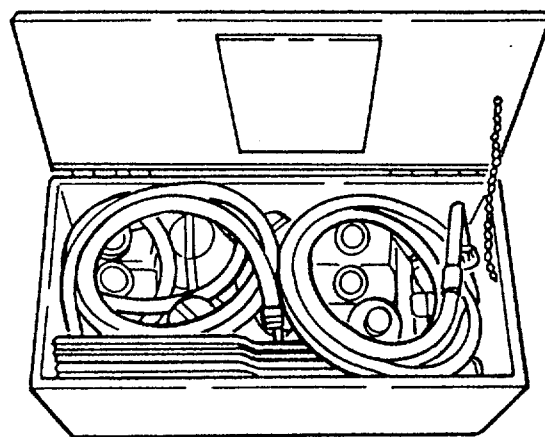

STORAGE BOX NO. 3

FIGURE 1-10. HOSES AND STORAGE BOXES

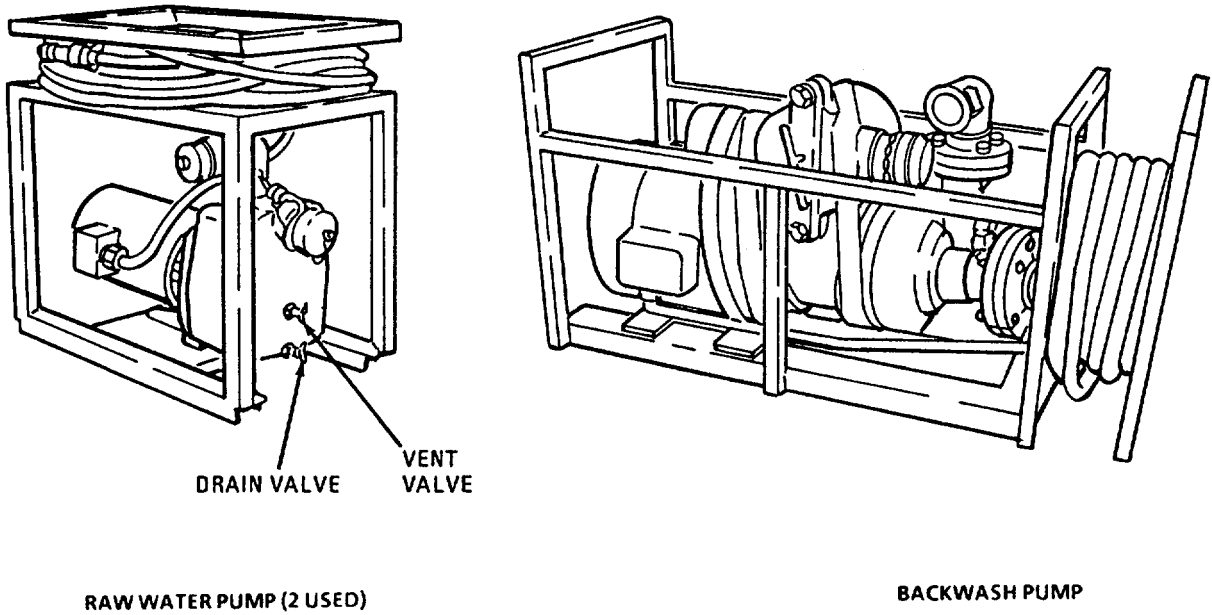

FIGURE 1-11. RAW WATER AND BACKWASH PUMPS

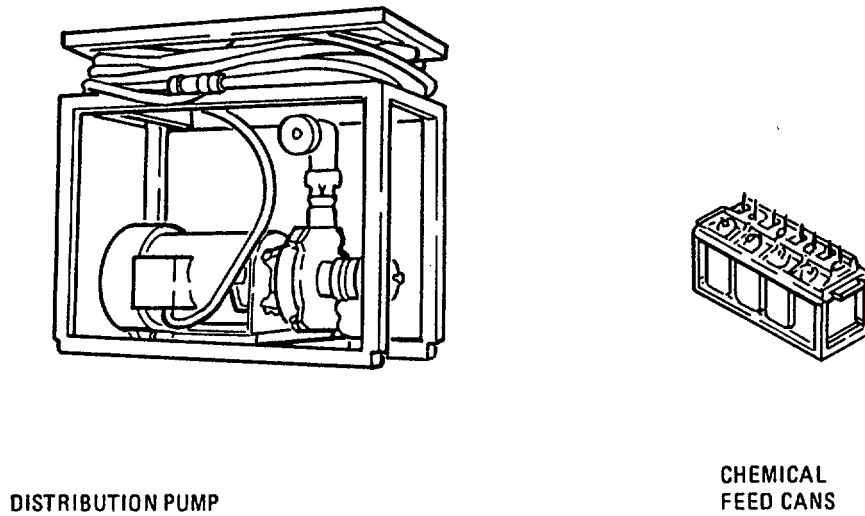
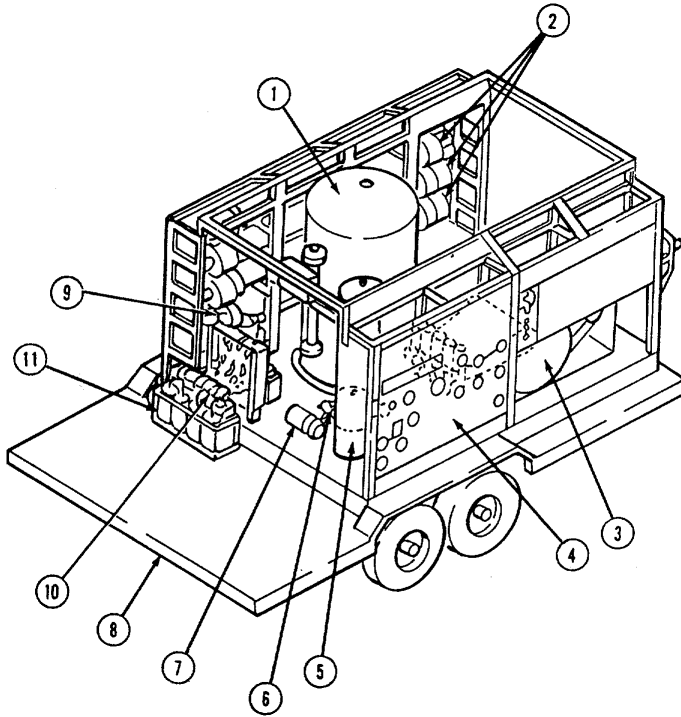

FIGURE 1-12. DISTRIBUTION PUMP



1. MULTIMEDIA FILTER
2. R.O. PRESSURE VESSELS
3. R.O. PUMP
4. CONTROL PANEL
5. CARTRIDGE FILTER
6. PULSE DAMPENER
7. BOOSTER PUMP
8. GENERATOR PLATFORM (ARMY)
9. PRIME/RUN VALVES
10. CHEMICAL FEED PUMP
11. CHEMICAL FEED CONTAINERS/RACK

NOTE

Illustration denotes Army ROWPU MC and AF units are skid-mounted with no generator platform.

FIGURE 1-13. ROWPU GENERATOR REMOVED (REAR VIEW)

e. Additional Components. Figure 1-13 identifies the following parts:

MULTIMEDIA FILTER (1). Provides first stages of removing matter from raw water.

R.O. PRESSURE VESSELS (2). Loaded with rolled, thin films (called elements). here, osmosis is reversed by applying pressure to reduce dissolved solids from raw filtered water.

R.O. PUMP (3). Applies high pressure to raw filtered water flowing through R.O. pressure vessels.

CONTROL PANEL (4). Panel on the control box assembly with meters, gauges, control valves, hose connections, and electrical switches.

CARTRIDGE FILTER (5). Provides cleaning to water coming out of the multimedia filter.

PULSE DAMPENER (6). Located behind the cartridge filter, reduces shock (water pulses) caused by R.O. pump.

BOOSTER PUMP (7). Forces water from multimedia filter through the cartridge filter and also provides a positive head pressure to R.O. pump.

GENERATOR PLATFORM (ARMY) (8). A 30-KW generator set is mounted on this platform.

PRIME/RUN VALVES (9). Allows chemical feed pumps to be primed in the PRIME position and dispenses chemicals in the RUN position.

CHEMICAL FEED PUMP (10). Pumps chemicals into water being processed.

CHEMICAL FEED CONTAINERS (I 11). Hold chemical solutions (polymer, sodium hex, citric acid, and chlorine) which are fed into chemical feed pump.

f. Trailer's Components. Figure 1-14 (ARMY) shows the location of the trailer's major components. MC and AF ROWPU's are skid mounted, but the frame is similar to that shown in figure 1-14.

1-7. EQUIPMENT DATA.

Dimensions and Weights (Trailer without ROWPU - Army Only)

Length	19.01 ft (5.8m)
Width	8.00 ft (2.44m)
Height (to top of the wheel cover)	3.18 ft (0.97m)
Weight	5,595 lbs (2540 kg)
Height to lunette	2.42 ft to 2.92 ft (0.74 m to 0.89 m)
Maximum towing speed	50 mph (80 kmh)
Tire pressure	75 psi (5.27 kg/sqcm)
Voltage	24 VDC

Power Requirements (Overall)

Power	22KW
Voltage	120 VAC, I-phase; 208-230/460VAC, 3-phase
Frequency	60 Hertz
Current	104 amp (max)

ROWPU Size - Trailer Mounted (ARMY)

Length	19.01 ft(5.8m)
Width	8.00 ft (2.44m)
Height	8.08 ft (2.45m)
Weight	16, 975 lbs (7700 kg)

ROWPU Dimensions - Skid Mounted (MC and AF)

Length.....	9.45 ft (2.86m)
Width	6.91 ft (2.07m)
Height	5.68 ft (1.7m)
Weight	7,300 lbs (3311.3 kg)

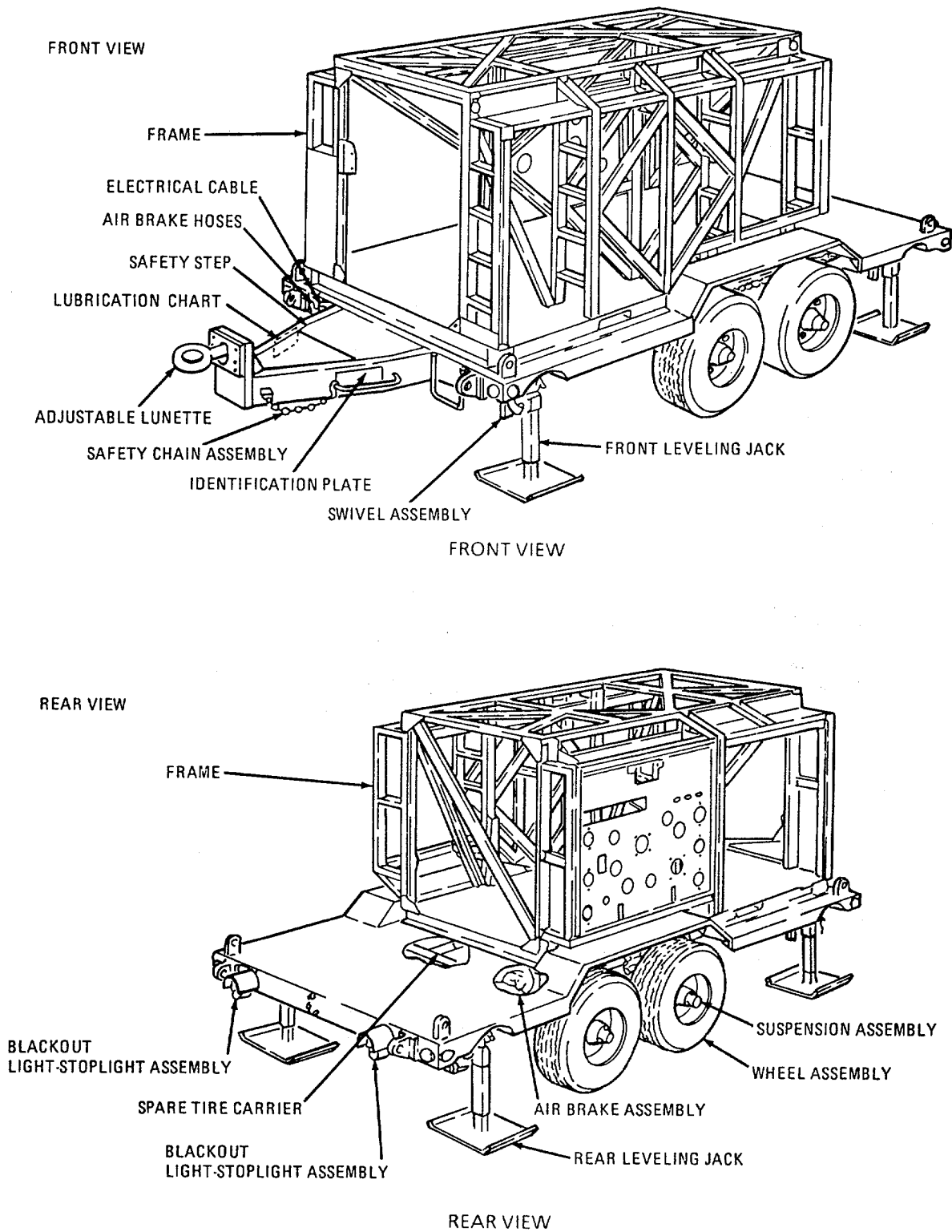

FIGURE 1-14. ROWPU FLATBED TRAILER AND FRAME (ARMY).

1-7. EQUIPMENT DATA - continued.

Distribution and Booster Pump Motors

Voltage 208-230/460 VAC, 3-phase
Current..... 3.4-3.2/1.6 amp
Horsepower..... 1
Frequency..... 60 Hertz
Revolutions Per Minute 3450
Duty Cycle Continuous

Distribution and Booster Pumps

Type..... Centrifugal
Capacity 30 gpm (114 lpm) 50 ft (15m) head
Drive Electric motor
Revolutions Per Minute 3500

Chemical Feed Pump Motor

Voltage 115/230 VAC, 1-phase
Current..... 2.0 amps
Horsepower 1/3
Frequency..... 60 Hertz
Revolutions Per Minute 1725
Duty Cycle Continuous

Chemical Feed Pump

Capacity..... 2.67 gallons/hr (10.3 liters/hr)
Drive Electric Motor

Multimedia Filter

Flow Rate..... 6.5 gpm/sq ft
Backwash Flow Rate..... 70 to 120 gpm (265 to 454 lpm)
Pressure Drop 5 psid (nominal) (3516kg/sqm)

Cartridge Filter

Cartridge (8 cartridge tubes)

Length 40 in (101.6 cm)
Flow Rate..... 35 gpm (132.5 lpm)
Pressure Drop 2 to 35 psid (1406 to 24,609 kg/sqm)

11-8. PIPING IDENTIFICATION.

The ROWPU piping is identified according to function by the following colors:

Function:	Color:
Raw Water	Black band
Backwash waste	Red band
Filtered Water	Yellow band
Product water	Blue band
Brine discharge	Purple band
Brine Piping on R.O. pressure vessels	Purple band

Section III. TECHNICAL PRINCIPLES OF OPERATION

	Page
Water processing and Chemicals	1-17
Reverse Osmosis (R.O.) Process.....	1-18

1-9. WATER PROCESSING AND CHEMICALS.

The ROWPU removes suspended solids (called turbidity), chemicals, and solids held in solution (called dissolved solids), found in most fresh water and seawater sources, to a level fit for human consumption. This is done by filtering with the aid of the reverse osmosis process, and then additional purification using selected chemicals. Refer to figure 1-15 to follow the process described below.

- a. First Stage of Filtration-Multimedia Filter. Before raw (untreated) water reaches the multimedia filter, polymer solution is added to it. Polymer collects suspended solids into groups large enough to be removed by the multimedia filter. This process is called coagulation. Water is then filtered through the multimedia filter.
- b. Second Stage of Filtration-Cartridge Filter. The cartridge filter takes out finer suspended solids that pass through the multimedia filter.
- c. Reverse Osmosis (R.O.) Elements. The first two stages of filtering do not remove dissolved solids from the water. The R.O. elements, through the R.O. process, remove dissolved minerals and any suspended solids that may have passed through the filters.
- d. Chlorine Disinfection. As the water leaves the ROWPU, chlorine is added as a disinfectant to reduce and maintain at an acceptable level any bacteria present in the product water. At this point, the product water is stored for human consumption.

1.10. REVERSE OSMOSIS (R.O.) PROCESS.

Reverse osmosis is the process by which purified water is separated from the available seawater or brackish water source. Pressure is applied to the raw water side of a semipermeable membrane, and desalinated water diffuses through the membrane to the freshwater side. The 600 GPH ROWPU is arranged so that prefiltered water is pumped under pressure across the semi-permeable membranes, called R.O. membranes. The R.O. membranes separate this water stream into a product water stream and a brine concentrate stream, both of which continuously flow away from the membranes.

CAUTION

Source water must be free of chlorine. Chlorine will instantly destroy beyond repair the R.O. elements. Destruction of the R.O. elements will make the ROWPU unable to meet its mission.

RAW WATER SOURCE (1). Any place you can get water.

STRAINER (2). A screen on the end of a suction hose to keep large particles that may clog or damage out of the pumps and filters of the ROWPU.

RAW WATER PUMPS (3) (4). Two each 30 GPM electric motor driven, centrifugal, portable pumps which draw source water through the strainer into the ROWPU under pressure. These pumps are normally connected in series.

POLYMER FEED PUMP (5). Adds polymer solution to raw water before it reaches multimedia filter to collect suspended solids into groups large enough to be removed by the multimedia filter. (This process is called coagulation).

SODIUM HEX FEED PUMP (6). Feeds diluted sodium hex to raw water to prevent scaling of filters, housings and pipes.

MULTIMEDIA FILTER (7). First stage of filtration. The multimedia filter contains six types of media: gravel, coarse garnet, fine garnet, silica sand, anthracite, and plastic. The water flowing into the filter discharges into a baffle to dissipate the velocity that could disturb the surface of the filter media. The water then flows through the filter and underdrains leaving larger suspended solids behind. The media bed is backwashed when: the loss of head pressure through the filter bed increases above a certain level; or the quality of the water flowing out fails to meet standards.

BOOSTER PUMP (8) Stabilized, centrifugal-type pump draws water from multimedia filter through the cartridge filter. The booster pump increases the water pressure for the second stage of filtration.

CARTRIDGE FILTER (9). Second stage of filtration. This filter removes finer suspended solids that pass through the multimedia filter by entrapment of the particles on the fibrous cylindrical material. The cartridge filter contains eight 40" spiral type filter tube elements. Cartridge filter elements should be replaced when cartridge filter gage differential pressure rises above 40 psid.

R.O. PUMP (10). High pressure (500 to 1000 psi), positive displacement pump supplies pressure to the R.O. vessels so that R.O. process can occur.

PULSE DAMPENER (11). A cylindrical shaped metal tank used to reduce pulses in water flow caused by pistons of R.O. pump.

R.O. ELEMENTS (12). Semi-permeable type membrane utilized under pressure to separate dissolved solids (the product water is forced through a membrane leaving dissolved solids on the membrane which are flushed out of the R.O. elements as brine). There are 4 vessels which house a total of 8 R.O. elements.

1-10. REVERSE OSMOSIS (R.O.) PROCESS - continued.

CHLORINE FEED PUMP (13). Adds chlorine to product water to reduce bacteria to an acceptable level to make water in tanks potable. Chlorine is injected after the reverse osmosis takes place.

PRODUCT WATER TANKS (14). Storage containers for product (potable) water.

DISTRIBUTION PUMP (15). Pumps potable water from product water tank into the water carrying vehicle or container.

DISTRIBUTION NOZZLE (16). Used for filling user's container with potable water coming from product water tanks by way of the distribution pump.

CITRIC ACID FEED PUMP (17). Adds diluted citric acid to filtered water to maintain the optimal pH for the R.O. process; aids in preventing scale buildup inside the R.O. membranes. To prevent coagulation at the R.O. elements make sure that the Citric Acid is fed prior to the item () .

BACKWASH WATER TANK (18). Stores brine water used for backwashing the multimedia filter and for cleaning the R.O. elements.

BACKWASH PUMP (19). Pumps brine water from the brine tank, through the backwash strainer, and into the multimedia filter to flush accumulated solids out of media.

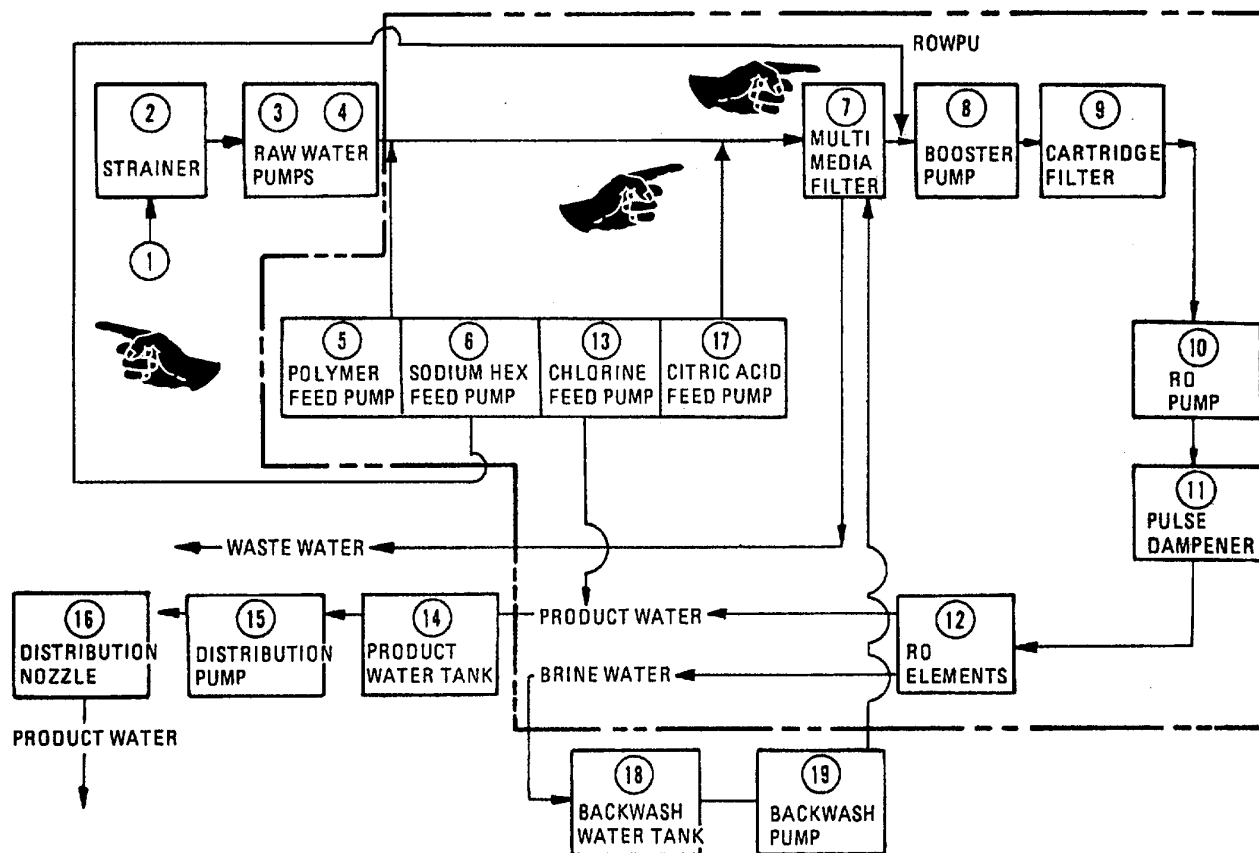

FIGURE 1-15. WATER PROCESSING BLOCK DIAGRAM

CHAPTER 2

OPERATING INSTRUCTIONS

Section I.	Description and Use of Operator's Controls and Indicators
Section II.	Preventive Maintenance Checks and Services
Section III.	Operation Under Usual Conditions
Section IV.	Operation Under Unusual Conditions

Section I. DESCRIPTION AND USE OF OPERATOR'S CONTROLS AND INDICATORS

	Page
Brake System	2-2
Circuit Breaker Panel	2-2
Control Box	2-2
Control Panel	2-2
Leveling Jacks	2-2
Product Water Totalizer	2-2
Spare Wheel and Tire Carrier Assembly	2-2
Trailer Controls and Indicators.....	2-1

2-1. TRAILER CONTROLS AND INDICATORS.

(ARMY) The only indicators on the flatbed trailer are the stop lights, tail lights, and the blackout light assembly. These lights are powered and controlled from the towing vehicle through a trailer cable. The plug on the cable (figure 2-1) and the receptacle make the system operational. The two air hoses connect to the towing vehicle brake system with glad-hand connectors (figure 2-2). When the trailer is not connected to the towing vehicle, the connectors are stowed on dummy couplers on the trailer to prevent damage and contamination.

CAUTION

Do not attempt to move trailer without releasing air brakes.

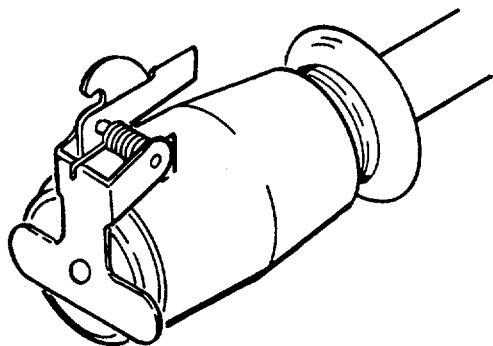

FIGURE 2-1. ELECTRICAL PLUG CONNECTORS

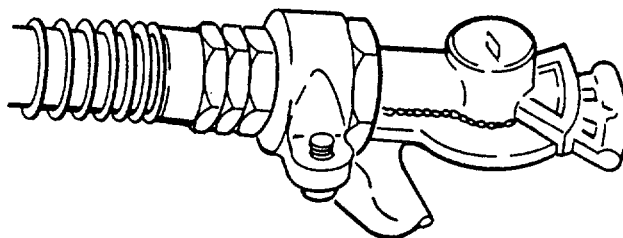

FIGURE 2-2. AIR HOSE GLAD-HAND

2-1. TRAILER CONTROLS AND INDICATORS - continued.

- a. Brake System (Army) The service brakes are air actuated and the controls are in part of the towing vehicle.

When the two air hoses from the trailer are connected to the connectors on the towing vehicle, the service brake system and the brake pedal on the towing vehicle automatically operate the trailer brakes. Disconnecting the air hoses causes the service brakes to engage automatically, thus serving as parking brakes for the trailer. Should the air supply from both the towing vehicle and the trailer reservoir be interrupted, a compression spring immediately locks the brakes. See figure 2-77 for procedure for resetting locked spring brake.

CAUTION

The leveling jacks must be in the stowed position (horizontal position) when towing or shipping the ROWPU by truck or rail.

- b. Leveling Jacks. (ARMY) The leveling jacks are secured by a swivel assembly to the support bracket located under the deck of the trailer at each corner. The swivel assembly contains a spring-loaded mounting assembly which can lock the assembly in either the vertical or horizontal position. In the vertical position, the jacks are used to level the trailer by raising or lowering the trailer corners as necessary. In the horizontal position the jacks are stowed. The front jacks, when locked in the vertical position, can also be used to assist in uncoupling the trailer from the towing vehicle. Turning the crank counterclockwise raises the jackpad; turning the crank clockwise lowers the jackpad.

- c. Spare Wheel and Tire Carrier Assembly. (ARMY) The spare wheel and tire carrier has a manually operated, cable-driven winch mounted on the frame structure at the rear end and underside of the trailer. The two (2) wheel lug nuts installed on the carrier are the same as those on the towing vehicle, thereby enabling the use of the vehicle's lug wrench for removal or replacement of the spare wheel assembly.

2-2. ROWPU CONTROLS AND INDICATORS.

The following paragraphs describe controls and indicators used to operate the ROWPU.

- a. Product Water Totalizer. The product water totalizer is located on the floor of the frame directly behind the booster pump as shown in figure 2-3. This meter is used to indicate the total number of gallons, in tenths of a gallon, of product water the unit has produced. The number of gallons is read directly from the numerals in the small window and the tenths of gallons from the position of the needle on the dial face.

- (1) One revolution of dial equals 10 gallons of product water produced.

- (2) The meter registers as follows:

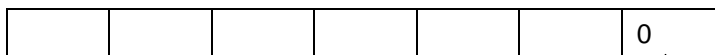

└─ Last digit is
 ZERO and is constant
 (does not move)

- (3) After one revolution, a total of 10 gallons are produced and the meter will register as follows:

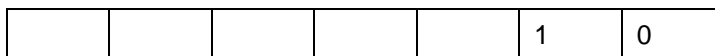

- (4) After two revolutions:

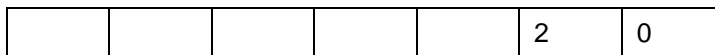

(5) After 10 revolutions:

				1	0	0
--	--	--	--	---	---	---

b. Control Panel. The control panel consists of various gages, valves, lights, switches, and hose connections as shown in figure 2-4, sheet 1. Their functions are described in table 2-1 (Keys 1 through 24).

c. Control Box. The control box consists of the pump control switches and indicator lamps as shown in figure 2-4, sheet 2. Their functions are described in table 2-1 (Keys 25 through 44).

d. Circuit Breaker Panel. The circuit breaker panel is located in the junction box and consists of circuit breakers for the pumps, utility outlets and backwash timer as shown in figure 2-4, sheet 3. Their functions are described in table 2-1 (Keys 45 through 53).

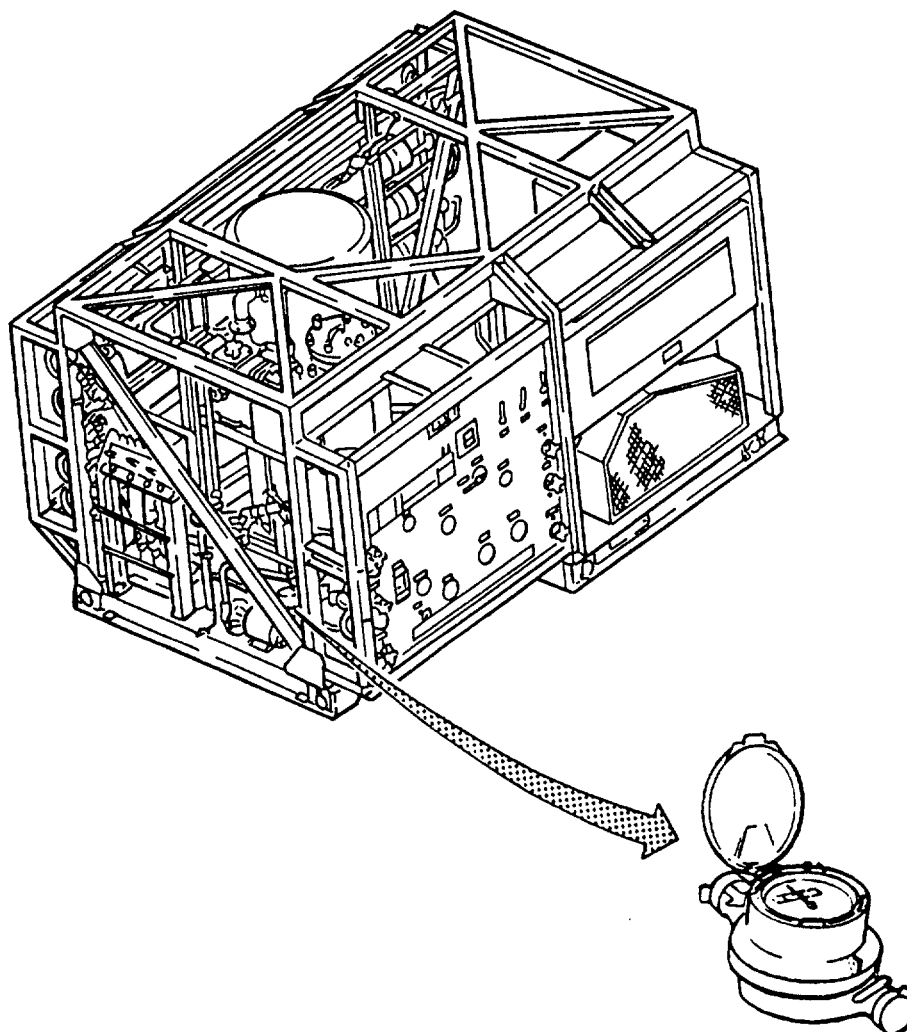

FIGURE 2-3. WATER METER

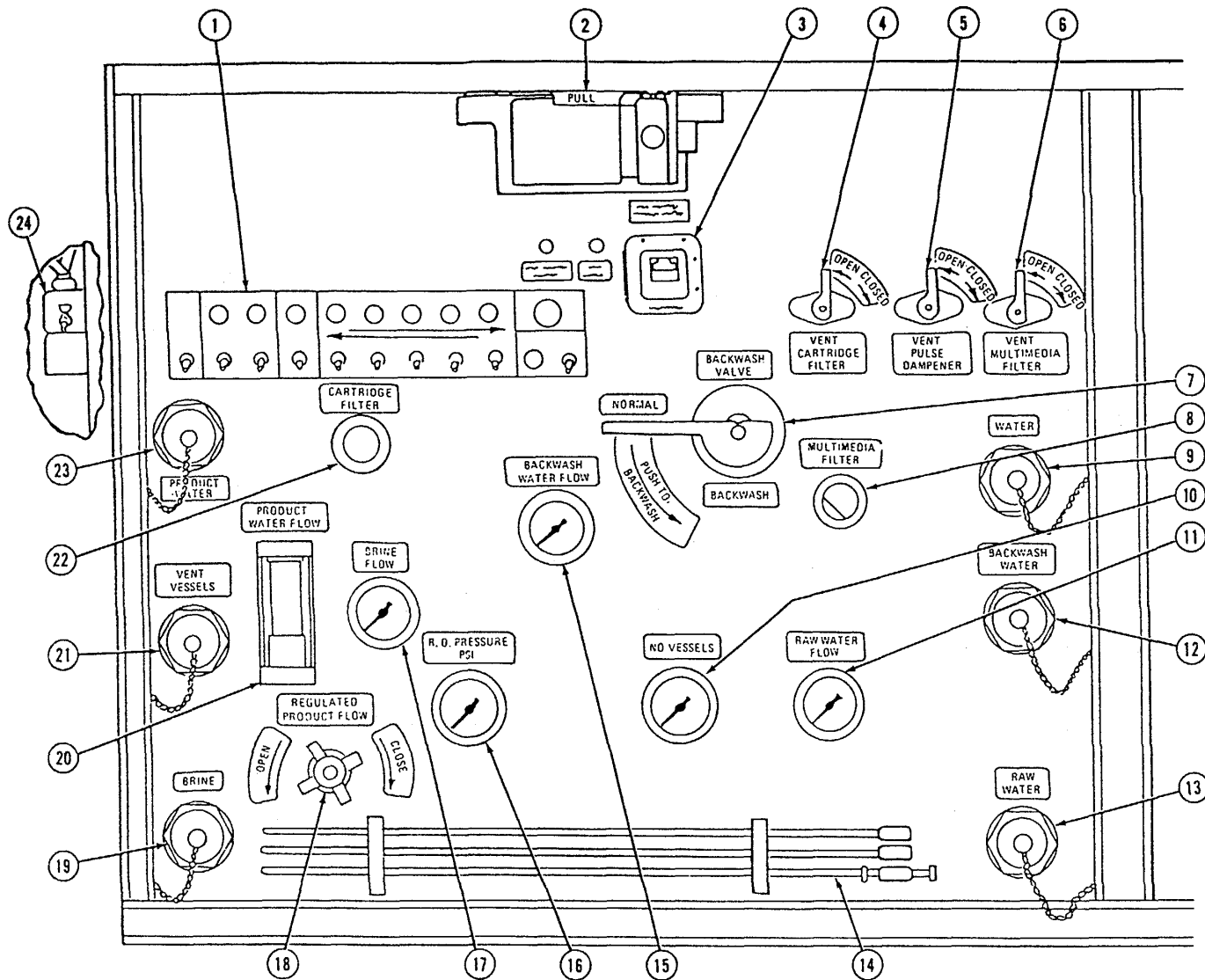

FIGURE 2-4. CONTROLS AND INDICATORS CONTROL PANEL (SHEET 1 OF 3)

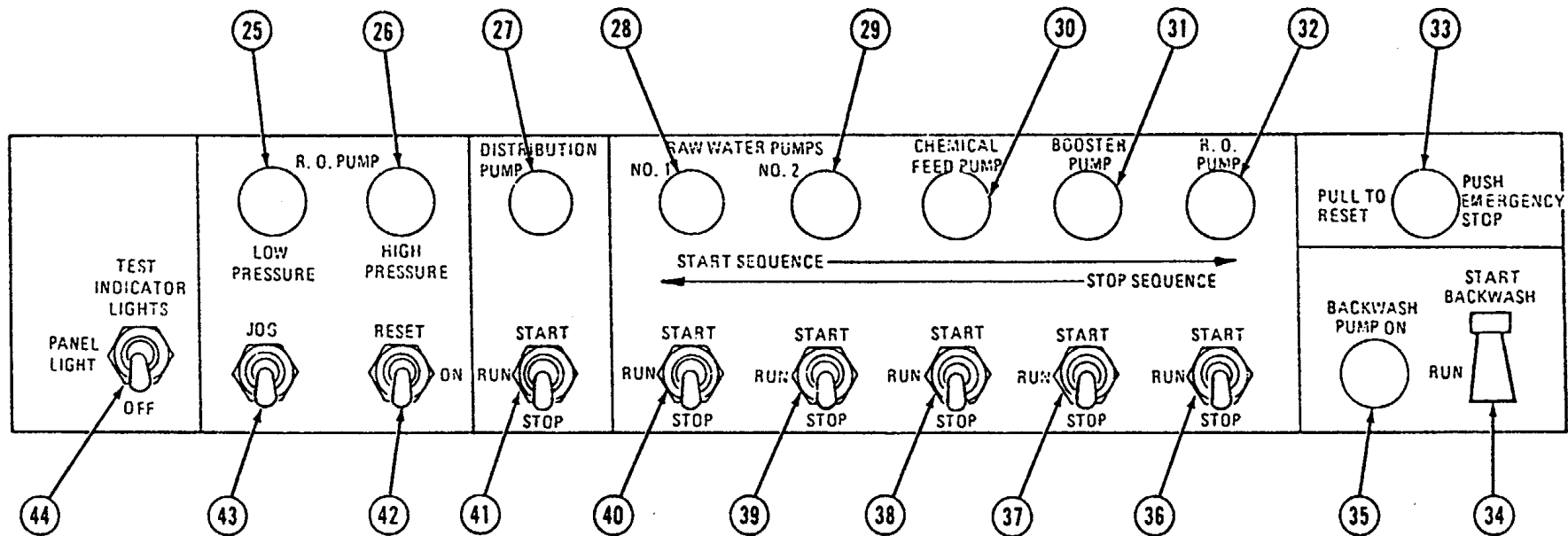

FIGURE 2-4. CONTROLS AND INDICATORS CONTROL PANEL (SHEET 2 OF 3)

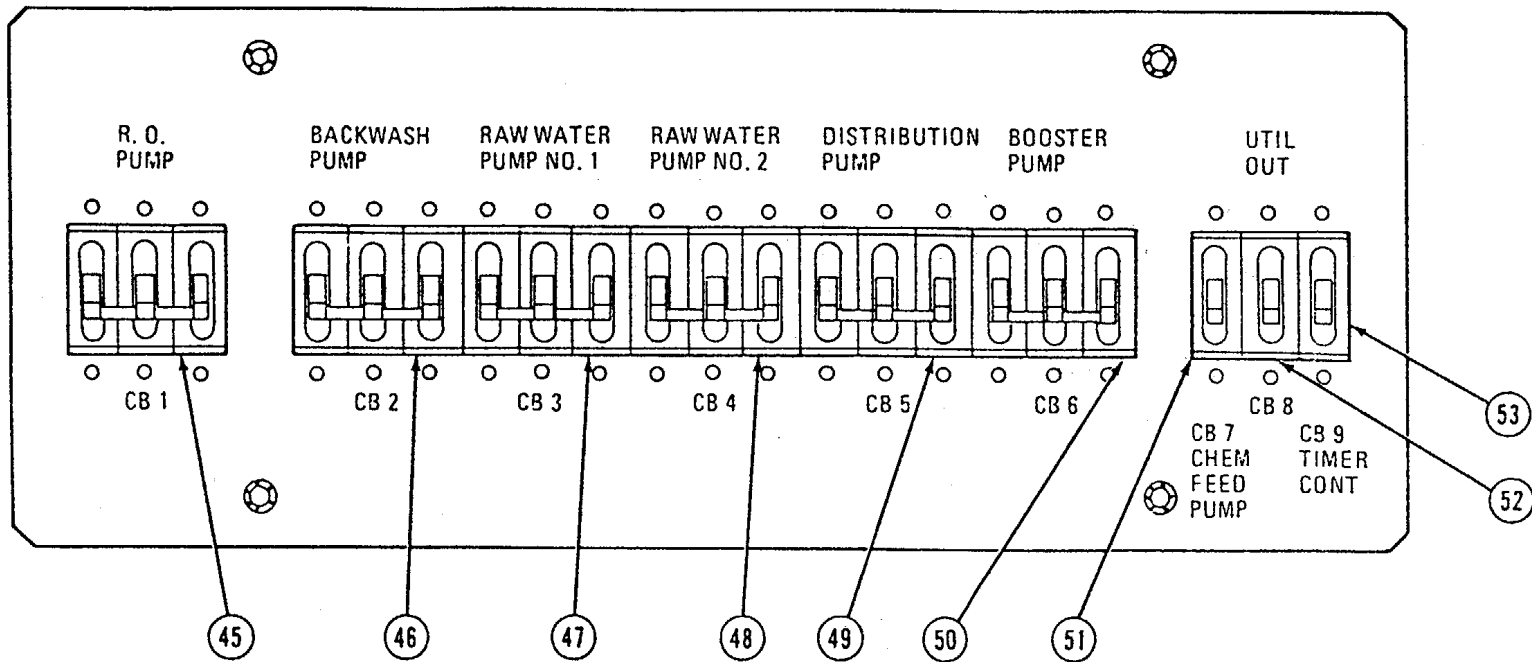

FIGURE 2-4. CONTROLS AND INDICATORS CIRCUIT BREAKER PANEL (SHEET 3 OF 3)

Table 2-1. Water Processing Controls and Indicators

Key	Control or Indicator	Function or Use
1	Control Box Assembly	Indicator lamps; switches to start, operate and stop (including EMERGENCY STOP) all pumps. (See figure 2-4 sheet 2, keys 25 through 44).
2	Panel Light	Provides light for inside of the ROWPU and for the control panel. It is mounted on a moveable bracket that can be pulled forward to provide more light on the control panel.
3	In-Line TDS Monitor	Used to continually monitor quality of product water (see figure 2-4, sheet 1).
4	Vent Cartridge Filter Valve	Relieves air from cartridge filter.
5	Vent Pulse Dampener Valve	Relieves air from pulse dampener.
6	Vent Multimedia Filter Valve	Relieves air from multimedia filter.
7	Backwash Valve	Backwash valve has two positions: NORMAL and BACKWASH. In NORMAL, the valve closes the backwash inlet and allows raw water to flow through the ROWPU. In BACKWASH, the raw water inlet is closed and water is allowed to flow through the backwash inlet. After backwashing, the valve should be returned to the NORMAL position.
8	Multimedia Filter Gage	Indicates differential pressure across the multimedia filter.
9	Waste Outlet	Connection for waste water produced when backwashing.
10	R.O. Vessels Gage	Indicates differential pressure across the R.O. vessels.
11	Raw Water Flow	Measures in gallons per minute the amount of water drawn in by raw water pumps and fed into ROWPU.
12	Backwash Water Inlet	Connection for backwash hose.
13	Raw Water Inlet	Connection for hose from raw water pumps
14	Ground Rod	Used to ground ROWPU. Protects personnel from electrical shock.
15	Backwash Water Flow Gage	Measures amount of water flowing through multimedia filter during backwash cycle.
16	R.O. Pressure P.S.I. Gage	Shows discharge pressure of the R.O. pump in pounds per square inch (psi). Gauge reading depends on setting of REGULATE PRODUCT FLOW valve.
17	Brine Flow Meter	Measures amount of brine flow from the ROWPU in gallons per minute (gpm).
18	Regulate Product Flow Valve	Closes the brine outlet of the R.O. vessels. Controls product water flow rate. Regulates output pressure of the R.O. pump.

Table 2-1. Water Processing Controls and Indicators (continued)

Key	Control or Indicator	Function or Use
19	Brine Outlet	Connection for brine water hose from ROWPU brine tank.
20	Product Water Flow Meter	Shows the number of gallons per minute of potable water put out by the ROWPU.
21	Vent Vessel Outlet stabilize.	Diverts water from R.O. vessels to allow multimedia filter to Also inputs R.O. element cleaning solution.
22	Cartridge Filter Gauge	Measures pressure drop across cartridge filter.
23	Product Water Outlet	Connection for drinking water from ROWPU to product water tank.
		CAUTION
		Element Cleaning switch must be OFF when backwashing the multimedia filter. Operating R.O. element cleaning during backwashing can cause damage to the R.O. elements.
24	R.O. Element Cleaning Switch	Used to operate backwash pump during cleaning of R.O. elements (switch must be OFF at all other times). (See figure 2-4, sheet 1)
		NOTE
		See figure 2-4 sheet 2 for illustration of items 25 through 44.
25	R.O. Pump Low Pressure Indicator Lamp	Lamp comes on when R.O. pump suction pressure drops below 10 psi. This lamp also indicates that R.O. Pump should have shut off.
26	R.O. Pump High Pressure Indicator Lamp	Lamp comes on when R.O. Pump discharge pressure is higher than 1250 psi. This lamp also indicates that R.O. pump should have shut off.
27	Distribution Pump Indicator Lamp	Lamp comes on when distribution pump motor is running normally.
28	Raw Water Pump No. 1 Indicator Lamp	Lamp comes on when raw water pump No. 1 motor is running normally.
29	Raw Water Pump No. 2 Indicator Lamp	Lamp comes on when raw water pump No. 2 motor is running normally.
30	Chemical Feed Pump Indicator Lamp	Lamp comes on when chemical feed pump motor is running normally.
31	Booster Pump Indicator Lamp	Lamp comes on when booster pump motor is running normally.
32	R.O. Pump Indicator Lamp	Lamp comes on when R.O. pump is running normally.

Table 2-1. Water Processing Controls and Indicators (continued)

Key	Control or Indicator	Function or Use
		CAUTION The EMERGENCY STOP switch should not be used to shut off the ROWPU except in emergency condition. To do so can cause damage to the equipment.
33	Push EMERGENCY STOP Switch	When pushed in, this switch shuts off power to ROWPU.
34	Start Backwash Switch	Toggle switch used to start the backwash pump motor.
35	Backwash Pump On Indicator Lamp	Lamp comes on when backwash pump motor is running normally.
36	R.O. Pump Start Switch	Toggle switch used to start, run, and stop the R.O. pump motor.
37	Booster Pump Start Switch	Toggle switch used to start, run, and stop the booster pump motor.
38	Chemical Feed Pump Start Switch	Toggle switch used to start, run, and stop the chemical feed pump motor.
39	Raw Water Pump No. 2 Start Switch	Toggle switch used to start, run, and stop the raw water pump No. 2 motor.
40	Raw Water Pump No. 1 Start Switch	Toggle switch used to start, run and stop the raw water pump No. 1 motor.
41	Distribution Pump Start Switch	Toggle switch used to start, run, and stop the distribution pump motor.
42	R.O. Pump High Pressure, Low Pressure Reset Switch	Toggle switch that resets the high-or-low-pressure switch after it shuts off the R.O. pump. If the malfunction has been corrected, this switch will turn off the LOW PRESSURE or HIGH PRESSURE indicator lamp.
43	R.O. Pump Jog Switch	Toggle switch that can be used to run the R.O. pump 3 to 5 seconds.
44	Panel Light Switch	Toggle switch used to turn the panel light on and off, and also used to test panel indicator lights.
		NOTE Items 45 through 53 are circuit breakers located in the junction box which provides electrical power for all electrical components. See figure 2-4, sheet 3.

Table 2-1. Water Processing Controls and Indicators (continued)

Key	Control or Indicator	Function or Use
45	R.O. Pump CB 1	Automatically shuts off power to R.O. pump motor if there is an electrical malfunction in the circuit.
46	Backwash Pump CB 2	Automatically shuts off power to the backwash pump motor if there is an electrical malfunction in the circuit.
47	Raw Water Pump No. 1 CB 3	Automatically shuts off power to raw water pump No. 1 motor if there is an electrical malfunction in the circuit.
48	Raw Water Pump No. 2 CB 4	Automatically shuts off power to raw water pump No. 2 motor if there is an electrical malfunction in the circuit.
49	Distribution Pump CB 5	Automatically shuts off power to distribution pump motor if there is an electrical malfunction in the circuit.
50	Booster Pump CB 6	Automatically shuts off power to booster pump motor if there is an electrical malfunction in the circuit.
51	CB 7 Chem Feed Pump	Automatically shuts off power to the chemical feed pump motor if there is an electrical malfunction in the circuit.
52	UTIL Out CB 8	Automatically shuts off power to the utility outlets if there is an electrical malfunction in the circuit.
53	CB 9 Timer Cont	Automatically shuts off power to the backwash timer and backwash pump motor if there is an electrical malfunction in the timer circuit.

e. Vent Vessels Valve. The vent vessel valve (figure 2-5) is located behind the control panel. Closing the vent vessels valve allows approximately 200-300 psi of filtered water pressure to build in R.O. vessels.

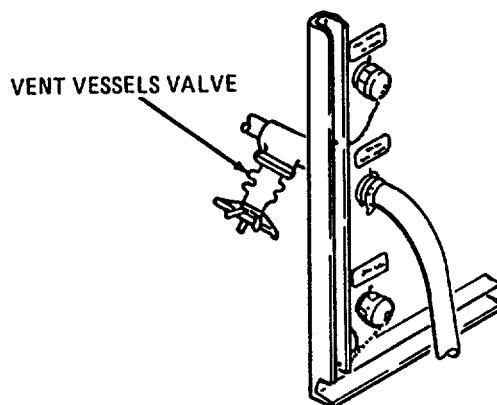

FIGURE 2-5. VENT VESSELS VALVE

f. Vent Product Water Valve. The vent product water valve (figure 2-6) is located to the right of the top R.O. vessel. It allows air to escape from the product water line. It is located on top of the product water manifold.

NOTE

All lever operated ball valves are in the ON position when control handle is in line with inlet and outlet lines.

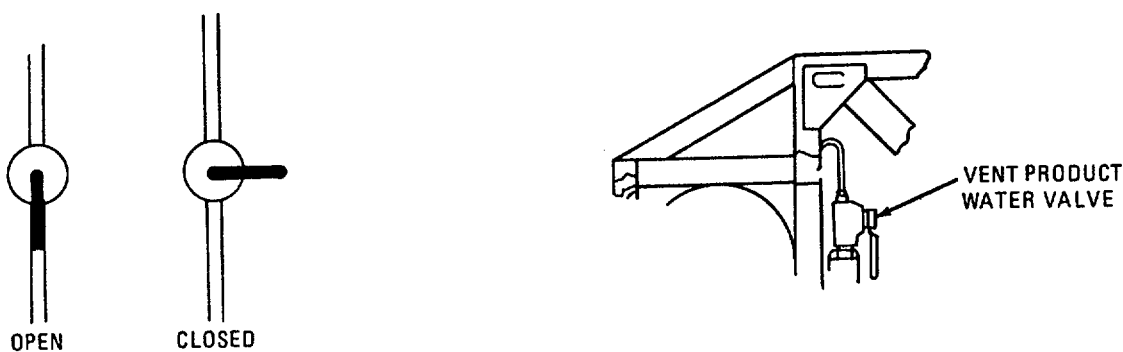

FIGURE 2-6. VENT PRODUCT WATER VALVE

g. Chemical Feed Pump Controls. Four control knobs are located as shown and are used to control the flow of each chemical.

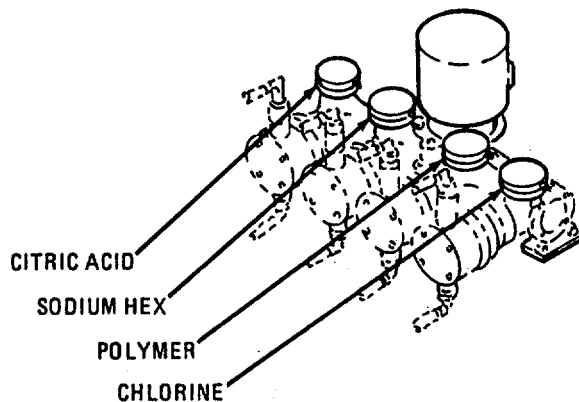

FIGURE 2-7. CHEMICAL FEED PUMP CONTROLS

h. Gate Valves. Two gate valves are used. One is installed between the brine tank and backwash pump, the other between the product water tanks; both regulate water flow.

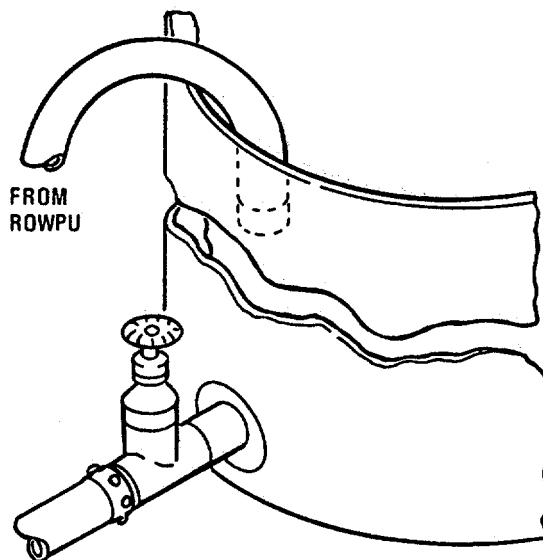

FIGURE 2-8. GATE VALVES

i. Drain Valves. Seven drain valves are located at the left front of ROWPU. They are used to draw samples at various stages of purification and to d-rain water from unit before moving.

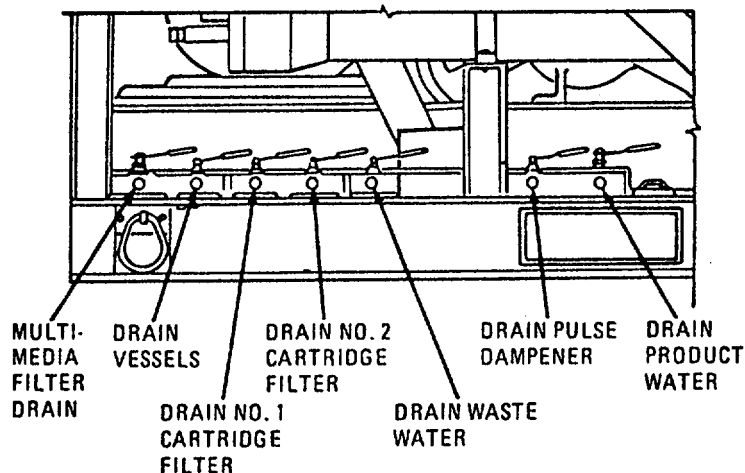

FIGURE 2-9. DRAIN VALVES

j. Chemical Feed Run and Prime Valves. Valves have two positions: PRIME and RUN. PRIME is for priming chemical feed pumps, and RUN for adding chemicals.

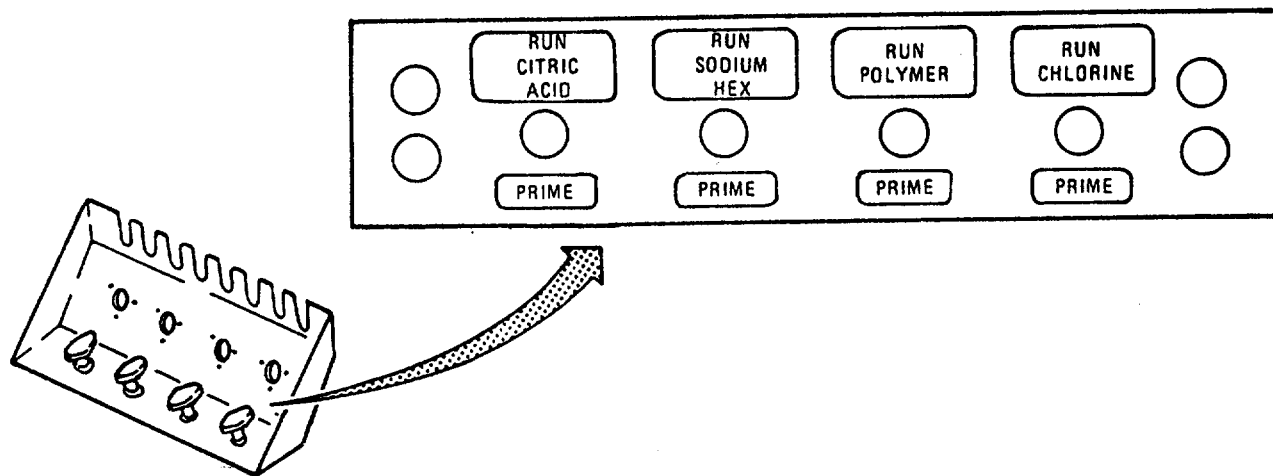

FIGURE 2- 10. CHEMICAL FEED RUN AND PRIME VALVES

l. Total Dissolved Solids (TDS) Meter. The TDS meter (figure 2-11) is used to measure total dissolved solids in raw and product water.

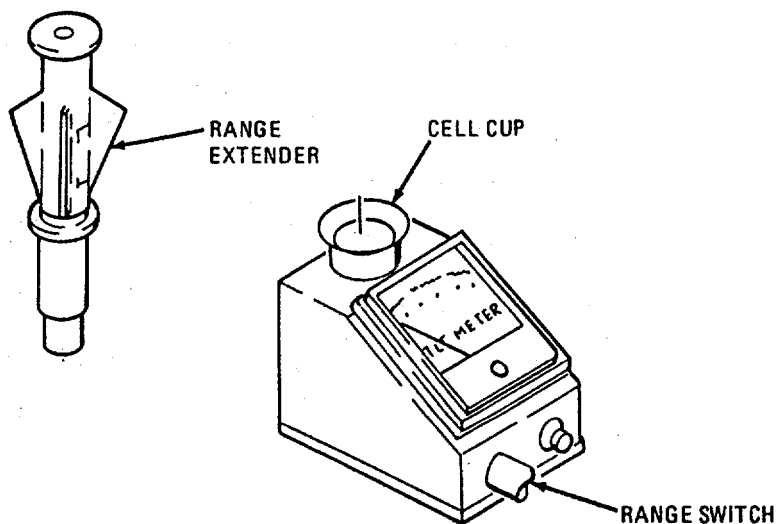

FIGURE 2-11. TOTAL DISSOLVED SOLIDS (TDS) METER

m. Turbidity Tube. The turbidity tube (figure 2-12) is used to see how clear the filtered water is.

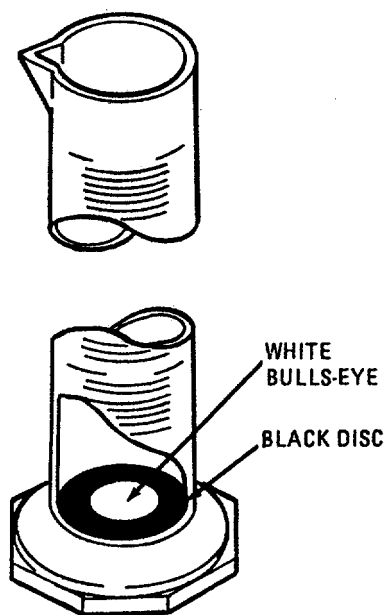

FIGURE 2-12. TURBIDITY TUBE

n. Color Comparator Kit. The color comparator kit is used to measure the amounts of chlorine in the product water and to determine its pH.

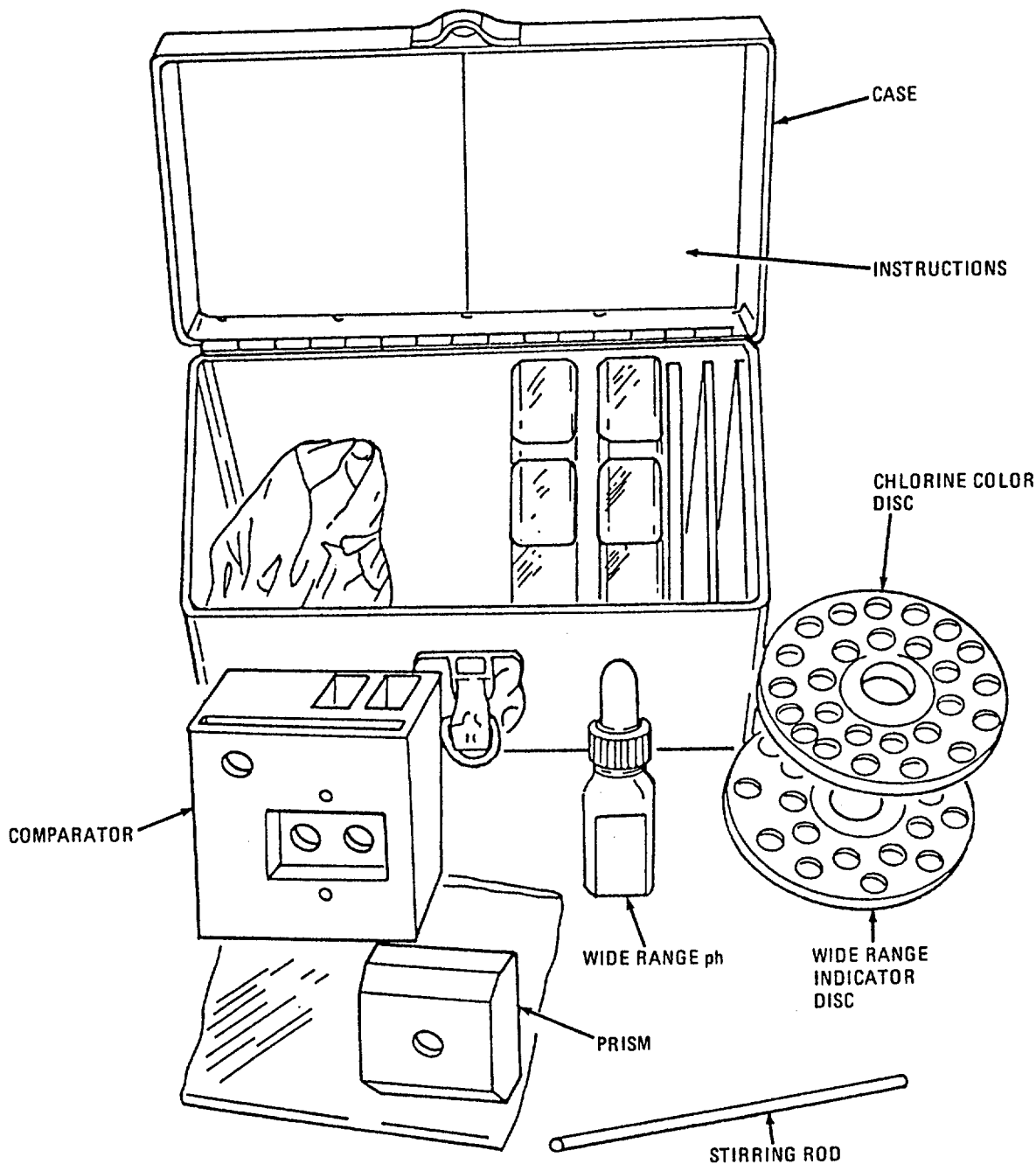

FIGURE 2-13. COLOR COMPARATOR KIT

- o. Backwash Timer. The backwash timer automatically starts and stops the different stages of the backwash cycle.

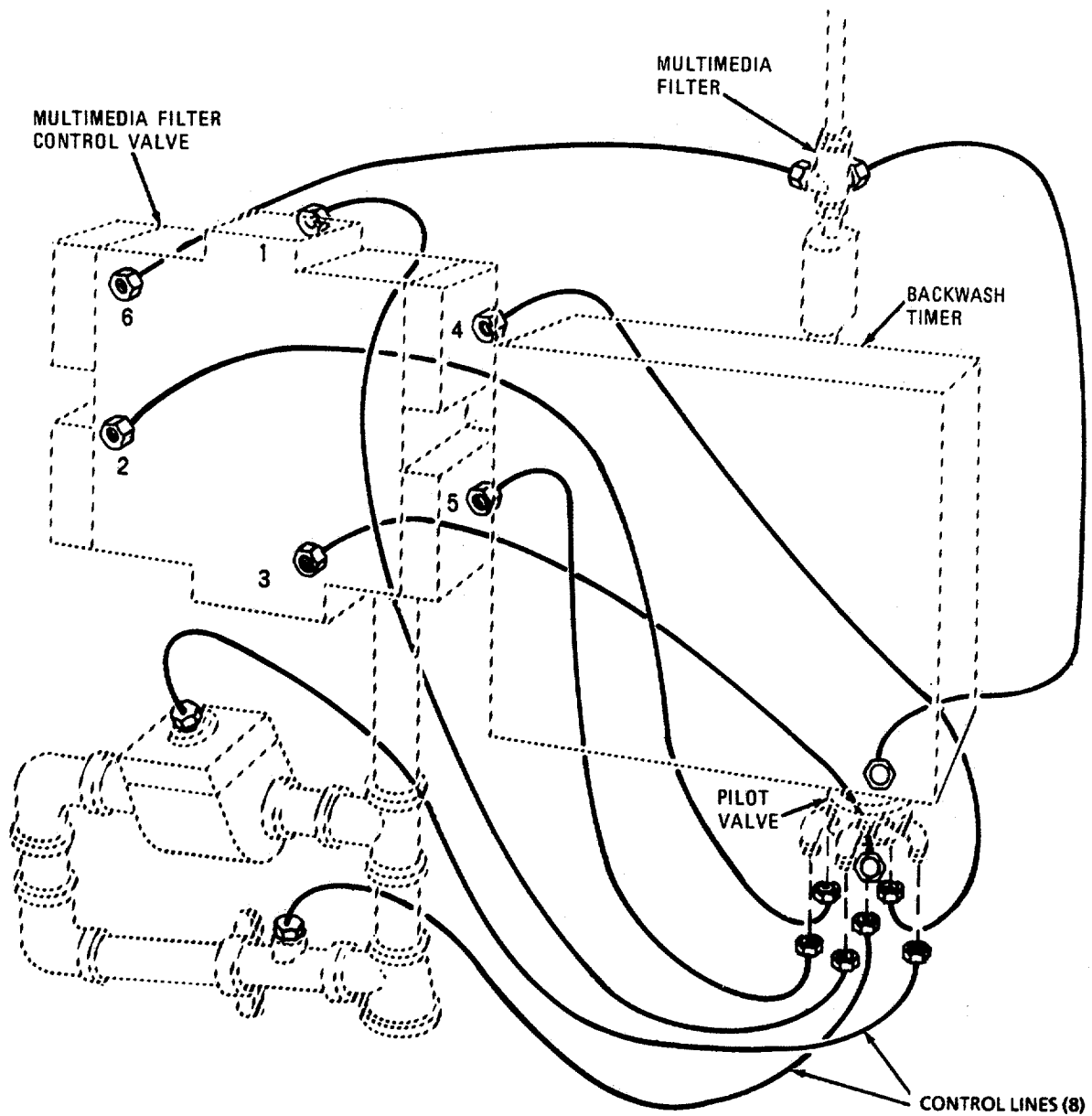

FIGURE 2-14. BACKWASH TIMER

Section II. PREVENTIVE MAINTENANCE CHECKS AND SERVICES (PMCS)

	Page
General	2-17
PMCS Procedures	2-17

2-3. GENERAL.

- a. Before You Operate. Always keep in mind each CAUTION and each WARNING. Perform "BEFORE OPERATION" (B) PMCS shown in tables 2-2 and 2-3.
- b. While You Operate. For your own safety and for protection of the equipment pay attention to each CAUTION and WARNING. Perform "DURING OPERATION" (D) PMCS shown in tables 2-2 and 2-3.
- c. After You Operate. Perform "AFTER OPERATION" (A) PMCS shown in tables 2-2 and 2-3.
- d. Weekly. Perform "WEEKLY" (W) PMCS shown in tables 2-2 and 2-3.
- e. Monthly. Perform "MONTHLY" (M) PMCS shown in tables 2-2 and 2-3.
- f. If the ROWPU Fails To Operate. Troubleshoot with proper equipment. Report difficulties, using the proper forms. Army users see DA PAM 738-750; Marine corps users refer to TM 4700-15/1. Air Force personnel refer to MAJCOM and local directives.

2-4. PMCS PROCEDURES.

- a. Performing PMCS, tables 2-2 and 2-3, will help keep ROWPU from breaking down.
- b. It is necessary to know what the numbers and letter on the table mean.

(1) Item number. Order in which ROWPU is checked. It will also be the item number to record result of PMCS in the "TM Number" column on DA Form 2404, Equipment Inspection and Maintenance Worksheet. Marine Corps personnel use form NAVMC 10524. Air Force personnel use form AFTO 349.

(2) Interval. When you make your checks:

- B "BEFORE OPERATION"
- D "DURING OPERATION"
- A "AFTER OPERATION"
- W "WEEKLY"
- M "MONTHLY"

(3) Item to be inspected. What should be inspected.

(4) Procedure. How to inspect the item.

(5) For readiness reporting, equipment is not ready/available if. Why and when you cannot use your equipment.

CAUTION

Under some operating conditions, slight water leaks may be observed from packing glands/mechanical seals. That is normal. If there is any doubt, or if equipment could be damaged, notify the supervisor or unit maintenance.

2-4. PMCS PROCEDURES - continued.

NOTE

Within designated intervals, perform these checks in the order listed. Perform weekly PMCS as well as before-operation PMCS if:

- (1) You are the assigned operator and have not operated the ROWPU since the last weekly PMCS.
- (2) Operating the item for the first time.

Table 2-2. (ARMY) Operator/Crew Preventive Maintenance Checks and Services (Trailer)

ITEM NO.	INTERVAL					Item to be Inspected	Procedures Check for and have repaired or adjusted as necessary.	Equipment is not ready/ available if:
	B	D	A	W	M			
1	.		.			Towing vehicle	Check that 24V power supply is electrical system. available to trailer.	24V not available.
2	.		.	.		Electrical connector and cable.	Check that connector and cable is in good condition. Insulation unbroken, connector free of dirt and corrosion.	Broken cable or connector.
3		Lights	Check that tail light, stop lights, and blackout lights work properly.	Light system inoperative.
4	.			.	.	Chassis wiring	Inspect for frayed or worn spots in wiring harness. deteriorated.	Wiring excessively frayed, worn or
5		Service Brake system	Start engine of towing vehicle to build up air pressure in brake system. Check for proper operation of brakes.	Pressure on brake pedal towing vehicle does not activate trailer brakes.
6	.		.			Air hose couplers	Make sure couplers are securely attached to towing vehicle (or dummy couplers if trailer not attached to a towing vehicle).	Couplers broken.

Table 2-2. (ARMY) Operator/Crew Preventive Maintenance Checks and Services (Trailer) - Continued

ITEM NO.	INTERVAL					Item to be Inspected	Procedures Check for and have repaired or adjusted as necessary.	Equipment is not ready/ available if:
	B - Before	D - During	A - After	W - Weekly	M - Monthly			
7	.		.	.		Air hoses	Check for cracks, leaks, or other damage.	Hoses broken or leaking.
8					.	Air brake tubing, reservoir, and other components.	Inspect for bends, dents, and leaks which may interfere with proper operation.	Parts badly damaged or leaking.
9			.	.		Air reservoir	Drain condensation by opening draincock; close draincock after draining.	Draincock broken or corroded. Check for broken or corroded draincock.
10	.		.	.		Tires	Check for proper inflation (75 psi); be sure tires are not excessively worn. Check that all tires are worn evenly.	Tires flat or below recommended pressure.
11	.		.			Nuts	Make sure lug nuts on wheels and other equipment fasteners have not worked loose. Check that cap nuts are properly seated and tight.	Any lug nuts missing.
12					.	Axles, springs	Visually inspect all structural parts for excessive wear, corrosion, broken welds.	Structural parts broken.
13	.		.	.		Trailer frame	Inspect for broken welds.	Welds broken.
14	.		.			Lunette	Inspect for loose or damaged bolts.	Lunette misaligned or loose.
15	.		.			Leveling jack cranks	Check that cranks are in place on support brackets.	
16	.		.	.		ROWPU frame	Inspect for broken welds.	Welds broken.

Table 2-3. (ARMY) Operator/Crew Preventive Maintenance Checks and Services (Unit)

ITEM NO.	INTERVAL					Item to be Inspected	Procedures Check for and have repaired or adjusted as necessary.	Equipment is not ready/ available if:
	B	D	A	W	M			
1	.	.	.			ROWPU, General	<p>Inspect the general appearance of the unit, paying particular attention to the words on identification markings and the condition of the paint. Inspect for rust, especially on weldments.</p> <p>Loose or missing bolts, screws, nuts, and hoses. Inspect for damage since the equipment was last used. Inspect for loose or broken cable connections.</p>	
2	.		.			Tools and Equipment	<p>Inspect tools and toolbox</p> <ul style="list-style-type: none"> • • Good shape • Clean • • All there • • In proper place • • Box mounts solid • • Box closes properly 	
3	.	.	.			Vent and drain lines	<p>Check vent and drain lines/connections</p> <ul style="list-style-type: none"> • Solid • Clean • All there • In proper place • No obstructions • Damage 	Lines are broken or clogged.
4	.		.			Frame and equipment	<p>Remove oil, grease, mud chemical spills, and other matter from all parts of the ROWPU. Use clean cloths. Wash the floor with product water.</p>	

Table 2-3. (ARMY) Operator/Crew Preventive Maintenance Checks and Services (Unit) - Continued

ITEM NO.	INTERVAL					Item to be Inspected	Procedures Check for and have repaired or adjusted as necessary.	Equipment is not ready/ available if:
	B - Before	D - During	A - After	W - Weekly	M - Monthly			
	B	D	A	W	M			
5		Multimedia filter	Inspect for leaky gaskets, and loose mountings. Notify organizational maintenance if you find trouble. Check multimedia gage readings. Should read within 5 psid of initial log reading, and in no case should exceed 10 psid.	Raw water will not flow through filter. Filter cannot be backwashed. Gage reading exceeds either 5 psid of initial log reading or 10 psid.
6		.				Cartridge filter	Check for leaks. Check cartridge filter gage readings. Should be 1-20 psid.	Raw water will not flow through filter. Gage reads over 20 psid.
7	.	.	.			Gages and flow indicators	Inspect for broken glass. Look for loose mountings and tube connections.	Gages or flow indicators are inoperative.
8	.		.			Frames: ROWPU Backwash pump, Distribution pump, Raw water pumps	Inspect for damaged or bent frames, loose mounting bolts, and missing or broken tiedowns and frame pins. Inspect crossmembers and beams for cracks and breaks. Tighten loose mounting bolts. Report breaks, misfits, cracks, damaged framework, or missing hardware to organizational maintenance.	
9				.		Canvas items: frame cover, pump covers, holddown straps	Inspect for rips, tears, or other damage. Report damaged items to organizational maintenance.	

Table 2-3. (ARMY) Operator/Crew Preventive Maintenance Checks and Services (Unit) - Continued

ITEM NO.	INTERVAL					Item to be Inspected	Procedures Check for and have repaired or adjusted as necessary.	Equipment is not ready/ available if:
	B - Before	D - During	A - After	W - Weekly	M - Monthly			
10	.	.	.			Hose, tanks, piping, tubing, fitting, strainers, and nozzle.	<p>Inspect for leaks. Look for hose pipe blockages. Are parts cracked or broken? Neither product water or brine tanks will hold water.</p> <p>CAUTION Don't overtighten. It will ruin threads. Stripped threads will cause connections to leak.</p> <p>Replace damaged raw water strainer, backwash pump strainer, and distribution nozzle. Report leaky tank to unit maintenance. Replace damaged hoses.</p>	There is not enough undamaged hose to set up the ROWPU.
11	.	.	.			Chemical feed equipment: containers/rack, plastic pails, tubes and strainers	<p>Inspect container/rack, pails and tubes for cuts, cracks or holes. Inspect during operation for leaks.</p> <p>Inspect strainer for clogging. After operation, clean container/rack, pails, tubes and strainers.</p>	Chemical feed containers and rack are so damaged that they will not hold chemicals. Tubes will not draw chemicals to the pumps.
12	.	.	.			Chemical feed pump	<p>Inspect for loose mounting nuts. Inspect for cracked or broken fitting. Add oil as necessary. Refer to LO 10-4610-240-10i LI0858C- 12/TO 40W4-13-31.</p> <p>CAUTION Chemical feed pump MUST NOT be operated on preservative oil. Doing so will damage pump and void warranty.</p>	Any one of the four pumps will not supply chemical to the purification cycle.

Table 2-3. (ARMY) Operator/Crew Preventive Maintenance Checks and Services (Unit) - Continued

ITEM NO.	INTERVAL					Item to be Inspected	Procedures Check for and have repaired or adjusted as necessary.	Equipment is not ready/ available if:
	B	D	A	W	M			
12 con't							Listen for unusual noises during operation. Notify organizational maintenance to replace malfunctioning pump. For sight glass location and oil filling instruction, see lubrication order LO 10-4610-240-12/LI 08580C-12/TO 40W4-13-31.	
13	.	.	.			Chemical feed pump motor.	Check for loose mounting nuts and bolts. Look for loose wires at conduit box. Listen for unusual noises during operation. Notify direct support maintenance to replace malfunctioning motor.	Motor will not operate.
14	.	.	.			Chemical feed Run/Prime valves	Inspect for broken or missing pipe to hose adapters. Check for free operation of valve handles. Check for chemical corrosion.	Blocked valves or excessive leakage.
15	.	.	.			Color comparator kit, TDS meter	Inspect the color comparator kit and TDS meter. Look for: <ul style="list-style-type: none"> • Poor condition • Dirty sample cells • Dirty color discs • Cracked or dirty frosted glass Clean as necessary.	
16	.	.	.			Regulate product flow valve and backwash valve	Inspect for loose pipe connections. Inspect valves to see if they operate freely and do not leak. Tighten loose connections. Notify unit maintenance if valves bind or leak.	Valves will not operate or excessive leakage.

Table 2-3. (ARMY) Operator/Crew Preventive Maintenance Checks and Services (Unit) - Continued

ITEM NO.	INTERVAL					Item to be Inspected	Procedures Check for and have repaired or adjusted as necessary.	Equipment is not ready/ available if:
	B - Before	D - During	A - After	W - Weekly	M - Monthly			
	B	D	A	W	M			
17		.	.			Vent and drain valves and drain cocks.	Inspect for leaks and proper operation. Inform unit maintenance of deficiencies. WARNING Do not operate ROWPU with open junction box; it can kill you.	Valves will not operate.
18	.			.		Junction box	Inspect the junction box for loose power cable connectors. Securely tighten any loose connections. WARNING Do not operate ROWPU with an open control box assembly; it can kill you.	Power cable connectors are loose.
19	.		.	.		Control box assembly.	Inspect outside for damage. Use TEST INDICATOR LIGHTS switch to ensure indicator lamps are functioning properly. Inspect plug connectors, toggle switches, and lamps for loose mountings and bad parts. Replace lamps that don't work. See that the junction box is securely mounted and kept closed.	Any toggle switch except PANEL LIGHT is broken. Junction box cover cannot be closed and fastened.
20	.					R.O. pump drive belt guard	Inspect belt guard for loose mounting bolts. Tighten all studs, nuts, and capscrews.	Belt guard off or loose.
21	.					R.O. pump drive belts	Check all five V-belts for cracks, rubbing, and signs of wear. Check belt tension: You should be able to push belts down only a half-inch at center of span.	Belts are defective or will not adjust properly.

Table 2-3. (ARMY) Operator/Crew Preventive Maintenance Checks and Services (Unit) - Continued

ITEM NO.	INTERVAL					Item to be Inspected	Procedures Check for and have repaired or adjusted as necessary.	Equipment is not ready/ available if:
	B	D	A	W	M			
22	.					R.O. pump, wiring, motor mounts, head gasket and piping.	Inspect wire connection going to junction box. Inspect the motor mounts for cracks or breaks. Look for dirt, corrosion, or water damage. Check for head gasket leaks and piping leaks.	
23				.		R.O. Pump Motor	<p>WARNING</p> <p>P-D-680 is potentially dangerous. Avoid repeated and prolonged breathing of vapors and skin contact with the liquid. Do not use near open flame, arcing equipment or other ignition sources. Always wear protective clothing and eyewear.</p> <p>Wipe motor with a clean cloth dampened with and approved cleaning solvent (P-D- 680).</p> <p>Lubricate in accordance with LO 10-4610-240-12/LI 08580C- 12/TO 40W4-13-31.</p> <p>Inspect for signs of overheating or too much wear.</p> <p>NOTE</p> <p>A new motor may run hotter for a few days. Change oil before first startup; watch oil level during break-in period.</p> <p>Listen for uneven, knocking sound.</p>	Motor makes unfamiliar sounds during operation.

Table 2-3. (ARMY) Operator/Crew Preventive Maintenance Checks and Services (Unit) - Continued

ITEM NO.	INTERVAL					Item to be Inspected	Procedures Check for and have repaired or adjusted as necessary.	Equipment is not ready/ available if:
	B	D	A	W	M			
24		.				R.O. Pump drain tube end	Inspect drain tube end to ensure that drain is open. Open restricted drain.	Drain clogged and cannot be cleared.
25	.	.				R.O. Pump cavity, seals, and plungers	<p>WARNING</p> <p>Use extreme care when working on operating equipment. Remove loose clothing, jewelry, and watches before removing R.O. pump cover plate.</p> <p>Remove two wing nuts and cover plate located on top of R.O. pump. Plungers and packing sleeve are now exposed. Inspect R.O. pump cavity for leakage at plunger sleeve.</p> <p>CAUTION</p> <p>R.O. pump MUST NOT be operated on preservative oil. Doing so will damage pump and void warranty. Excessive leakage will contaminate the crankcase oil and score the plungers.</p> <p>Water leakage into the cavity past the packings is normal and aids cooling. As packings wear from normal operation, the water leakage will become more severe. When this occurs, tighten packings as follows:</p> <ol style="list-style-type: none"> 1. Get packing adjustment tool from storage box No. 2. 	Excessive leakage cannot be controlled.

Table 2-3. (ARMY) Operator/Crew Preventive Maintenance Checks and Services (Unit) - Continued

ITEM NO.	INTERVAL					Item to be Inspected	Procedures Check for and have repaired or adjusted as necessary.	Equipment is not ready/ available if:
	B	D	A	W	M			
25 cont							operating at normal system pressure, insert end of tool in packing sleeve. Slowly tighten packing sleeve ¼ turn and check for leakage. Repeat until leak has been reduced to an acceptable amount.	2. With R.O. pump
other							leaking packings. If excessive leakage cannot be controlled, the packings, and plungers if scored, must be replaced. Report this condition to organizational maintenance.	3. Repeat step 2 for
26			.			Low and High pressure switches	Inspect for loose or damaged wires. Report loose or damaged wires to organizational maintenance.	Switch cases are broken. Bare wires are visible.
27	.	.	.			Pump assemblies	Inspect the pumps for loose mountings, damaged frames, cracked housings, and leaky seals. Inspect pumps for proper rotation. Listen for unusual noises from pumps or pump motors during operation.	Pumps do not work or excessive leakage.
28	.		.			Cable assemblies	Inspect electrical cable assemblies for cracked, broken or cut insulation. Inspect connectors on ends of cables. Report any unserviceable cable assembly to organizational maintenance.	Cables are broken or bare wires are visible.

Table 2-3. (ARMY) Operator/Crew Preventive Maintenance Checks and Services (Unit) - Continued

ITEM NO.	INTERVAL					Item to be Inspected	Procedures Check for and have repaired or adjusted as necessary.	Equipment is not ready/ available if:
	B	D	A	W	M			
29	.	.				Backwash timer	Inspect outside for cleanliness. Inspect for loose wiring. Wipe dirt from timer. Report a non-operating timer to organizational maintenance.	Backwash timer does not work.
30	.		.			Ground rod	Inspect for damaged ground wire connections, and loose, damaged, or missing screw joints and driving bolt. Clean and tighten ground connections and screw joints. Report unserviceable ground rods to organizational maintenance.	If any section of ground rod is unusable.
31				.		Data and instruction holders and plates	Inspect for damage and for missing parts.	
32		.				R.O. vessel assemblies	Inspect for damage (cracks, breaks, leaks), and loose or missing mounting hardware. Tighten loose hardware. Report damaged assemblies to organizational maintenance.	Any R.O. vessel is cracked or broken; R.O. vessels leak around seals.
33		(ARMY) 30-KW generator set	Inspect and service generator set as shown in applicable manual for generator (TM 5-6115-465-12 for NSN 6130-01-182-1240).	
34	.		.			(ARMY) Portable step	Inspect for rust and cracked or broken weldments.	
35	.		.			Storage boxes	Inspect for broken panels. Check for broken or missing hardware. Report damage to organizational maintenance.	

Table 2-3. (ARMY) Operator/Crew Preventive Maintenance Checks and Services (Unit) - Continued

ITEM NO.	INTERVAL					Item to be Inspected	Procedures Check for and have repaired or adjusted as necessary.	Equipment is not ready/ available if:
	B	D	A	W	M			
36	.	.	.			Special tools: paddle, R.O. element puller, bulb puller	Inspect for bent shafts and stripped threads. Replace damaged tools.	
37	.		.			Circuit breakers	Inspect for cracked or broken parts. Before connecting generator set, check for free movement of handle. Inspect for signs of burning or arcing.	Any circuit breaker is damaged or will not move easily.
38	.	.	.			Water testing equipment: beaker, graduated cylinder, solution indicator, thermometer, turbidity tube	Check for cracked or broken glass. Check to see that all markings are readable. Replace damaged items.	
39	.					Rupture disc assembly	Before operation, make sure an intact rupture disc is in place. Check for leaks around rupture disc assembly. seat.	An intact rupture disc is not in place. There is leakage around rupture disc
40	.	.				Pulse dampener	Inspect for broken, corroded, or missing mounting hardware. Check for cracks on weldment. Inspect for leaks.	There is any damage to weldment.
41	.	.				High pressure relief valve	Inspect for corrosion. Check for leakage at base of relief valve.	There is excessive leakage at relief valve.
42	.					In-line TDS monitor	Inspect for damage. control panel.	Install on
43	.	.				Water meter	Inspect for damage or leakage. Ensure cover is closed when readings are not being taken. Ensure that meter reads properly during operation.	Excessive leakage.
44	.	.				NBC Cartridge Filters	Check for leaks at hose/adaptor connections. Change NBC cartridge filters after every 100 hours of use.	

Section III. OPERATION UNDER USUAL CONDITIONS

	Page
Backwash of Multimedia Filter	2-69
Citric Acid Feed	
Choosing the Site	2-30
Initial Adjustment and Checks	2-50
Operation of Auxiliary Equipment	2-78
Operating Procedures	2-56
Preparation for Movement	2-80
Preparation for Use.....	2-30
R.O. Element Cleaning Methods	2-72
R.O. Element Cleaning Procedures	2-72
Safety Valves	2-55
Shutdown Procedures	2-76

2-5. CHOOSING THE SITE.

When choosing the site to set up and run the ROWPU, remember the following:

- a. If a stream is to be used as the raw water source, pick a site for the ROWPU upstream from camp.

NOTE

Illustration denotes Army ROWPU. Mc and AF units are skid mounted.

WARNING

Ensure that the site provides downstream waste water drainage away from the water source.

CAUTION

Consider variable weather conditions when choosing site; avoid areas vulnerable to flash flooding and high tide.

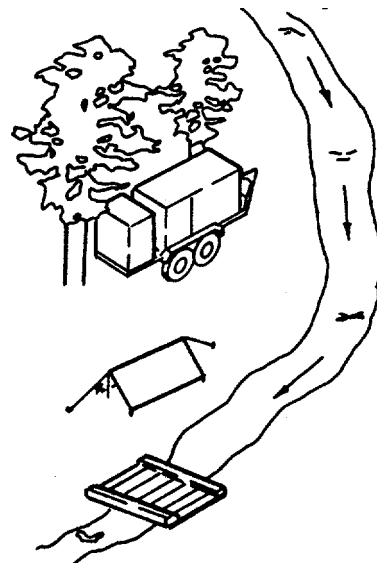

FIGURE 2-15. SITE DIAGRAM

- b. The raw water hoses can reach about 75 feet. Ensure the ROWPU is placed close enough for the hoses to reach the water source, and check that the ground is solid and fairly level.
- c. Take advantage of available forest cover.
- d. Take advantage of finished roads. They can furnish a solid, level surface.

2-6. PREPARATION FOR USE

Upon reaching the operating area, prepare the ROWPU for operation. For ARMY units refer to figure 2-16 for trailer set-up, then follow paragraph 2-6a(1) through 2-6a(26). For skid-mounted units (MC AND AF), skip to paragraph 2-6a (1) through 2-6a(26).

1. CHOOSE A SITE AS NEARLY LEVEL AS POSSIBLE; CLEAR SITE OF ROCKS AND VEGETATION. BE SURE SURFACE IS FIRM ENOUGH TO SUPPORT THE TRAILER-MOUNTED ROWPU.

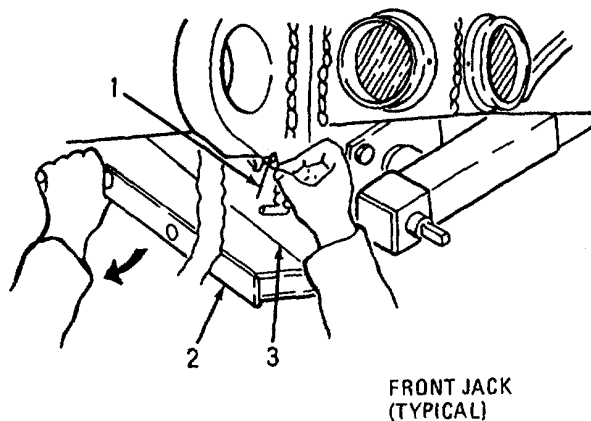

3. REMOVE SAFETY PIN (1) AND CRANK HANDLE (2) FROM REAR OF JACK SUPPORT BRACKET (3).

WARNING: LEVELING JACK IS SPRING LOADED. USE CARE WHEN PULLING OUT LEVELING JACK TO PREVENT PERSONAL INJURY.

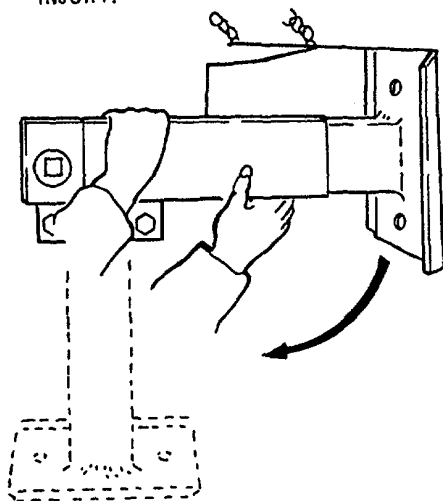

5. TO ROTATE FRONT LEVELING JACK TO LEVELING POSITION, REMOVE CRANK HANDLE. GRASP JACK AND PULL STRAIGHT OUT AGAINST SPRING TENSION ROTATE JACK DOWN TO VERTICAL POSITION. ALLOW JACK TO SPRING BACK TO LOCKED POSITION.

2. MANEUVER TRAILER INTO POSITION WITH TOWING VEHICLE. BE SURE ALL SIDES OF TRAILER, AND ALL FITTINGS AND CONTROLS FOR THE ROWPU ARE EASILY ACCESSIBLE. IF TOWING VEHICLE IS TO BE DISCONNECTED FROM TRAILER, USE FRONT LEVELING JACKS TO HELP IN UNCOUPLING.

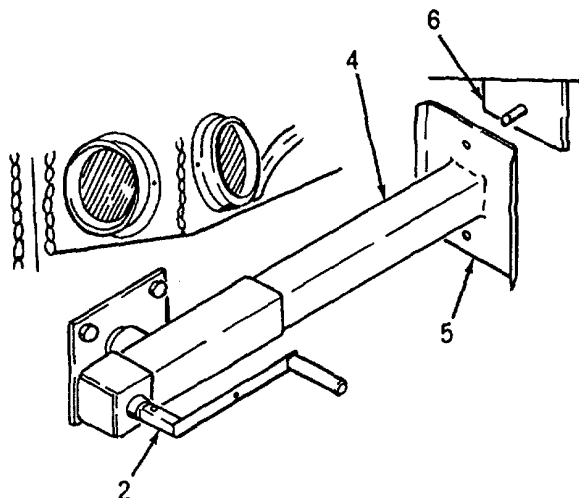

4. POSITION CRANK HANDLE (2) ON JACK (4) AND TURN HANDLE COUNTERCLOCKWISE TO RETRACT JACK UNTIL JACK PAD (5) IS CLEAR OF SECUREMENT PLATE (6) ROUND BAR.

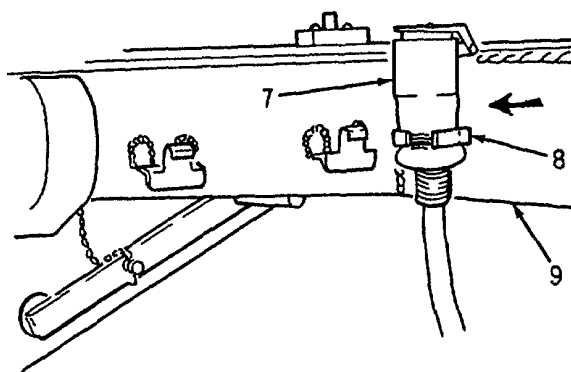

6. DISCONNECT ELECTRICAL CONNECTOR (7) FROM TOWING VEHICLE. STOW CONNECTOR IN STOWAGE CLIP (8) ON TRAILER DRAWBAR (9).

FIGURE 2-16. PREPARATION FOR USE (SHEET 1 OF 4) (ARMY)

NOTE: TWO PERSONNEL OPERATING BOTH FRONT LEVELING JACKS
ARE REQUIRED TO RAISE THE TRAILER

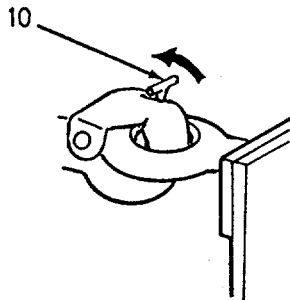

7. RELEASE PINTLE (10) BY LIFTING PINTLE LEVER.,
RAISE PINTLE.

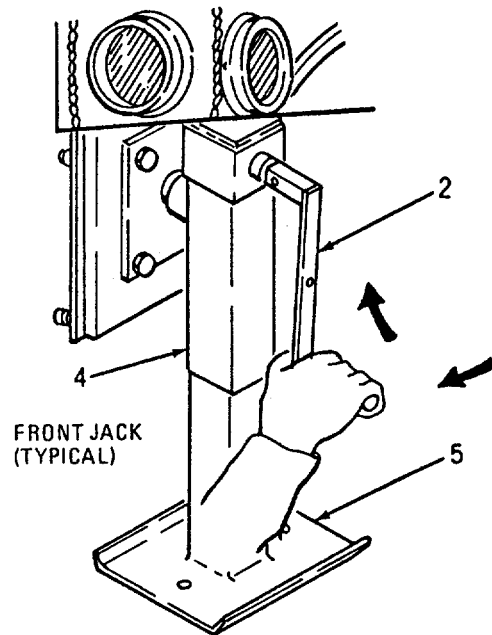

8. POSITION CRANK HANDLE (2) ON JACK (4) AND TURN HANDLE
CLOCKWISE TO LOWER JACK PAD (5). CONTINUE TO LOWER
BOTH FRONT JACKS UNTIL WEIGHT OF TRAILER RESTS ON JACKS
INSTEAD OF TOWING VEHICLE, AND LUNETTE IS CLEAR OF
PINTLE.

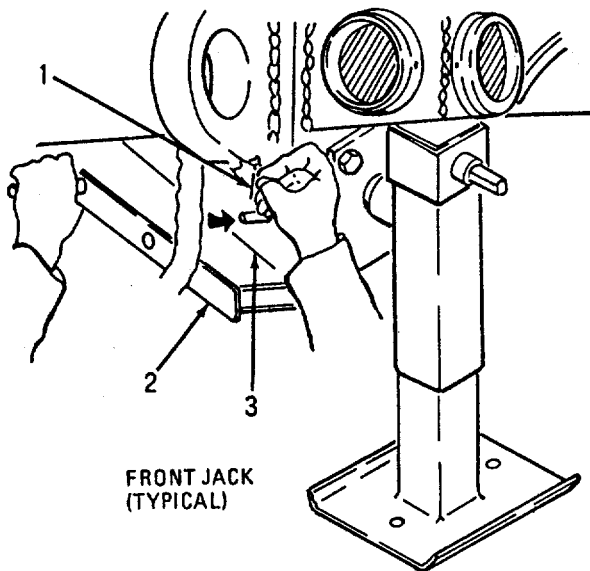

9. REPLACE CRANK HANDLE (2) ON REAR OF JACK
SUPPORT BRACKET (3); INSTALL SAFETY PIN (1).

FIGURE 2-16. PREPARATION FOR USE (SHEET 2 OF 4) (ARMY)

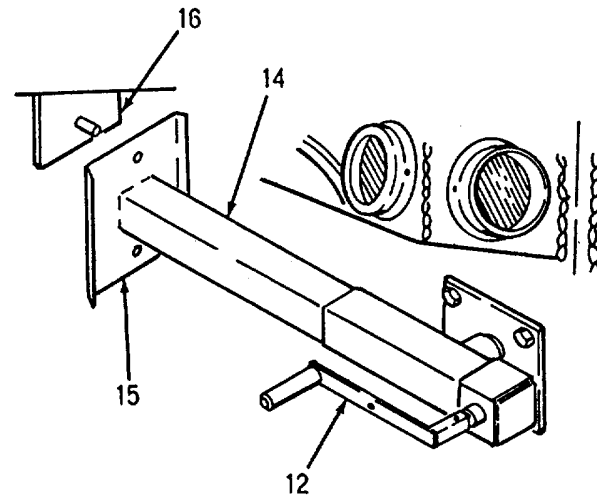
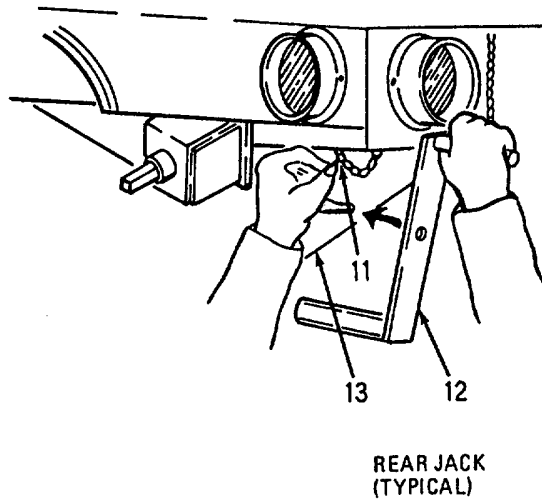

10. REMOVE SAFETY PIN (11) AND CRANK HANDLE (12) FROM REAR OF JACK SUPPORT BRACKET (13).

11. POSITION CRANK HANDLE (12) ON JACK (14) AND TURN HANDLE COUNTERCLOCKWISE TO RETRACT JACK UNTIL JACK PAD (15) IS CLEAR OF SECUREMENT PLATE (16) ROUND BAR.

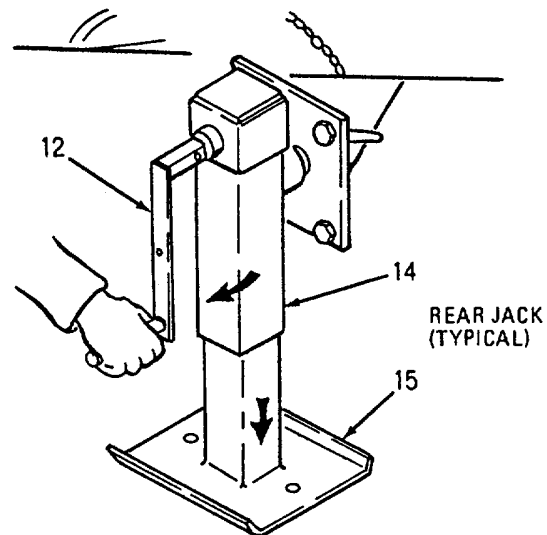
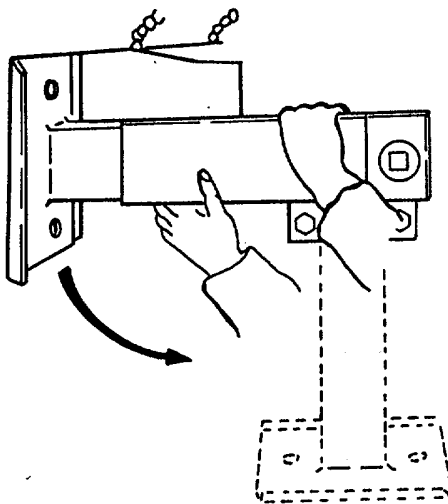

12. TO ROTATE REAR LEVELING JACK TO VERTICAL POSITION, REMOVE CRANK HANDLE. GRASP JACK AND PULL STRAIGHT OUT AGAINST SPRING TENSION. ROTATE JACK DOWN TO VERTICAL POSITION. ALLOW JACK TO SPRING BACK TO LOCKED POSITION.

13. POSITION CRANK HANDLE (12) ON JACK (14) AND TURN HANDLE CLOCKWISE TO LOWER JACK PAD (15). CONTINUE TO LOWER BOTH REAR JACKS UNTIL JACK PADS REST FIRMLY ON THE GROUND.

FIGURE 2-16. PREPARATION FOR USE (SHEET 3 OF 4) (ARMY)

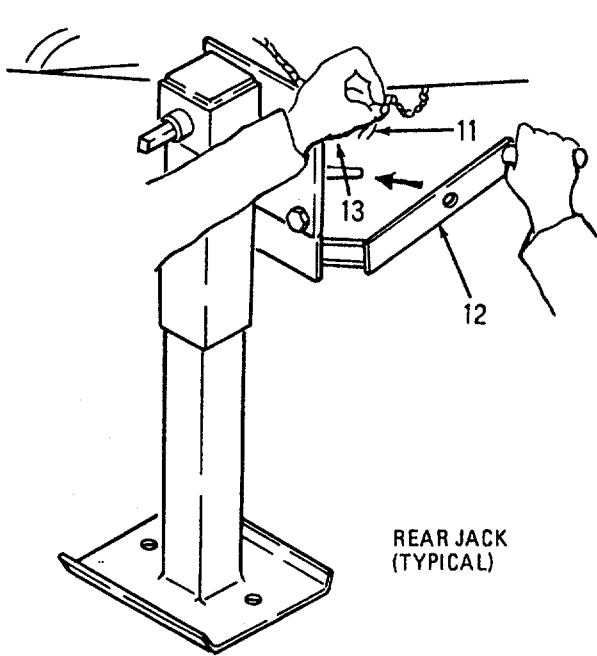

REAR JACK
(TYPICAL)

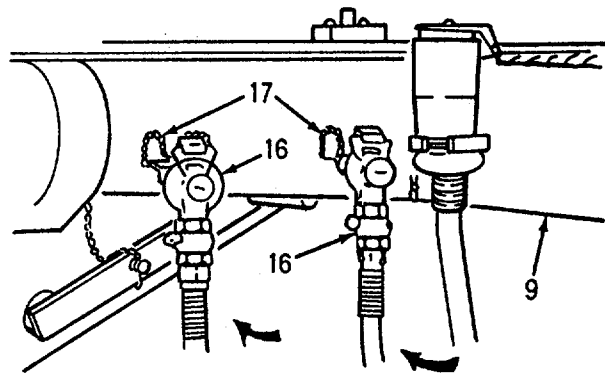

15. CLOSE AIR BRAKE COUPLING LEVERS. DISCONNECT AIR HOSES (16) FROM TOWING VEHICLE. PARKING BRAKES ARE NOW SET. STOW AIR HOSES (16) ON DUMMY COUPLINGS (17) PROVIDED ON TRAILER DRAWBAR (9).

14. REPLACE CRANK HANDLE (12) ON REAR OF JACK SUPPORT BRACKET (13); INSTALL SAFETY PIN (11).

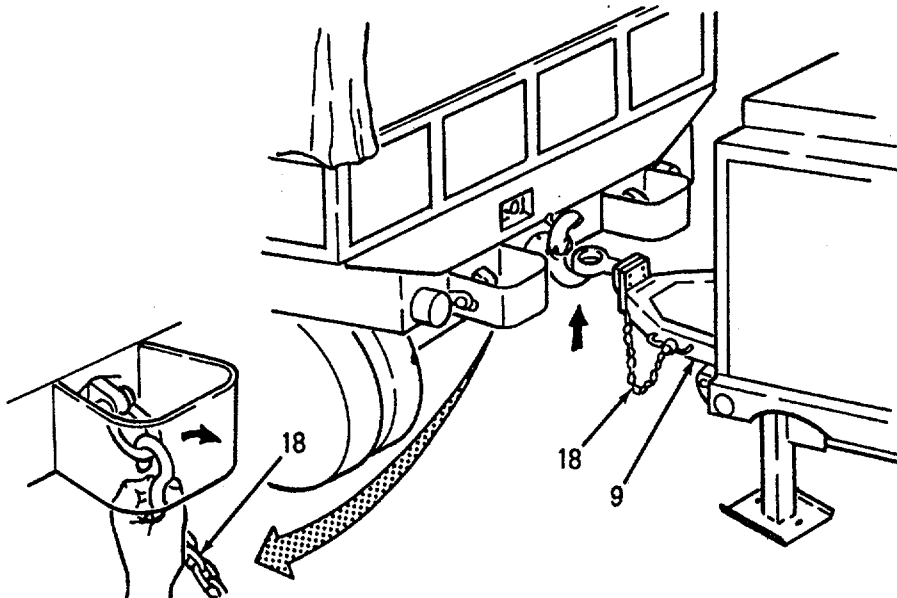

16. DISCONNECT TRAILER SAFETY CHAIN (18) FROM TOWING VEHICLE. PLACE TRAILER SAFETY CHAIN (18) IN STOWED POSITION ON TRAILER DRAWBAR (9).

FIGURE 2-16. PREPARATION FOR USE (SHEET 4 OF 4) (ARMY)

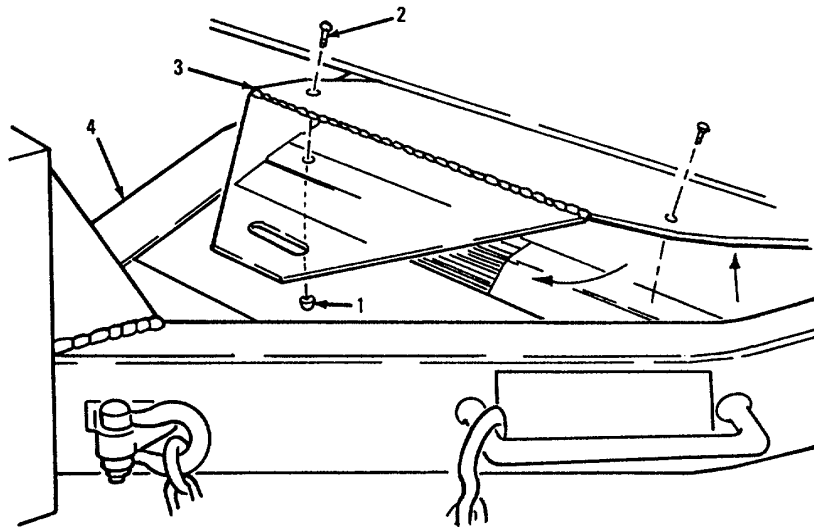

1. REMOVE NUTS (1) AND SCREWS (2) SECURING SAFETY STEP (3) IN PLACE. LAY SAFETY STEP DOWN ON DRAWBAR (4) AND INSTALL PREVIOUSLY REMOVED NUTS AND SCREWS.

FIGURE 2-17. UNFOLD SAFETY STEP (ARMY)

a. Cover Removal.

- (1) Roll up the canvas cover over the ROWPU frame and fasten with tie-back straps.

NOTE

Illustration denotes ARMY ROWPU. MC and AF units are skid-mounted.

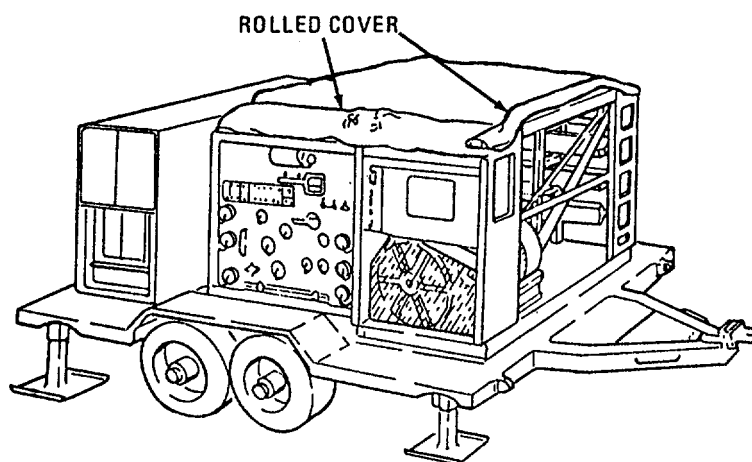

FIGURE 2-18. CANVAS COVER TIED BACK

(2) Looking at the ROWPU from above, with canvas removed, you can see various items stored.

NOTE

Illustration denotes ARMY ROWPU. MC and AF units are skid-mounted with a separately packed distribution pump and chemical feed container/rack. Step ladder is supplied with ARMY units only.

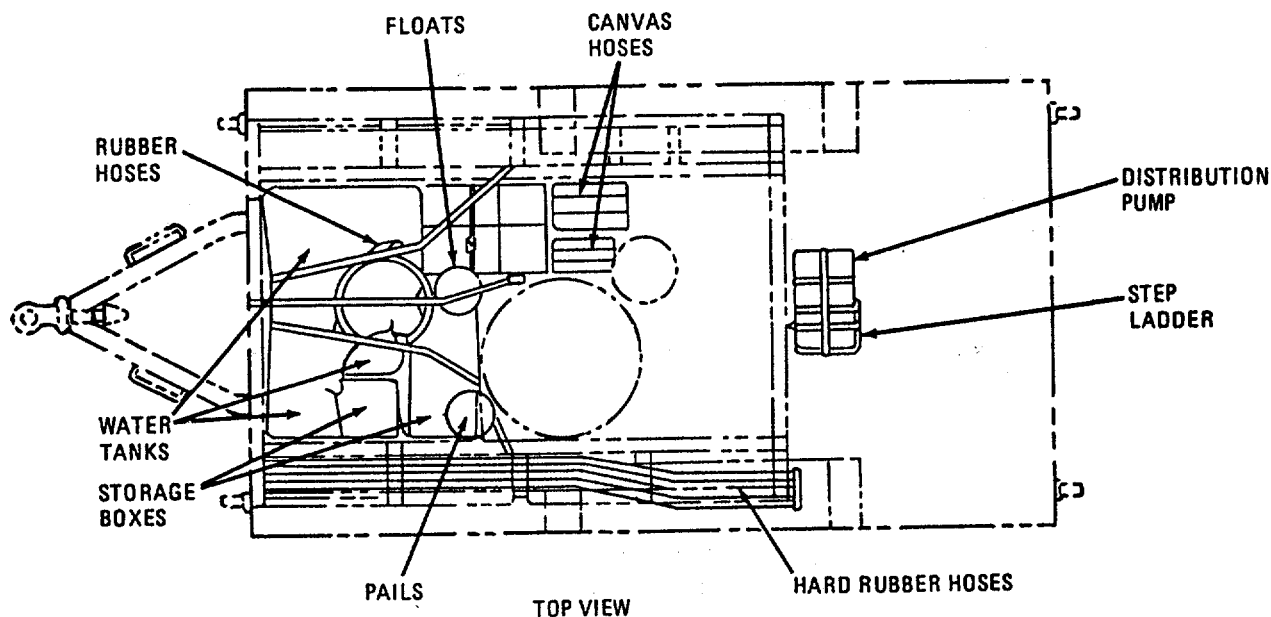

FIGURE 2-19. TOP VIEW OF ROWPU

(3) Remove the two frame cross braces. Store them on top of ROWPU canvas. Release cargo straps by loosening the sawtooth (ratchet) holders. Unsnap hooks on bottom of straps. Roll up cargo straps and put them on top of ROWPU canvas. Remove all tape, paper, and cardboard packing material. Remove protective caps and plugs from all valves, pipes, and vent openings.

NOTE

Illustration denotes ARMY ROWPU. MC and AF units are skid mounted.

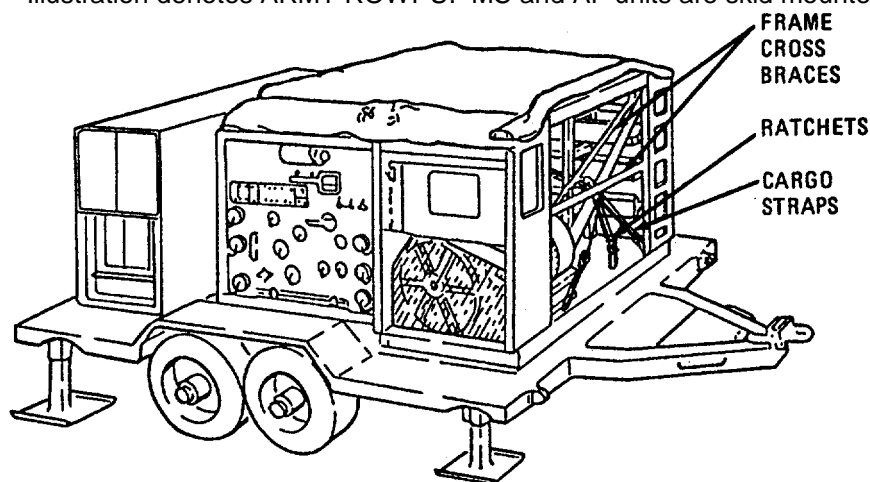
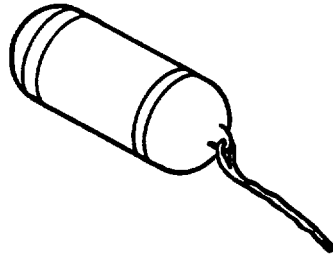

FIGURE 2-20. CROSS BRACES, CARGO STRAPS, RATCHETS

b. Accessory Removal.

- (1) Remove one suction hose float and five chemical pails.



FLOAT

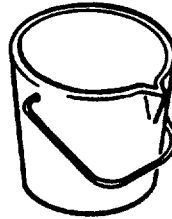

UTILITY PAILS

- (2) Remove three hard rubber suction hoses that are used for raw water input. Be careful not to damage threaded ends.

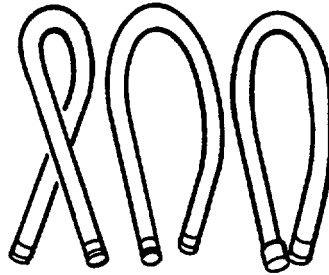

RUBBER HOSES

- (3) Remove from ROWPU overpack: One brine tank, (6, figure 2-21).
- Two product water tank, (7) and (8).
 - Paddle, (12)
 - Sledge hammer, (11).
 - Chemical feed container, (16).
 - One 2 inch and nine 1 1/2-inch suction (hard rubber) hoses (13); nine discharge (canvas) hoses; three 2-inch and six 1 1/2-inch hoses.
 - Storage boxes (9) and (10) (remove but do not unpack).

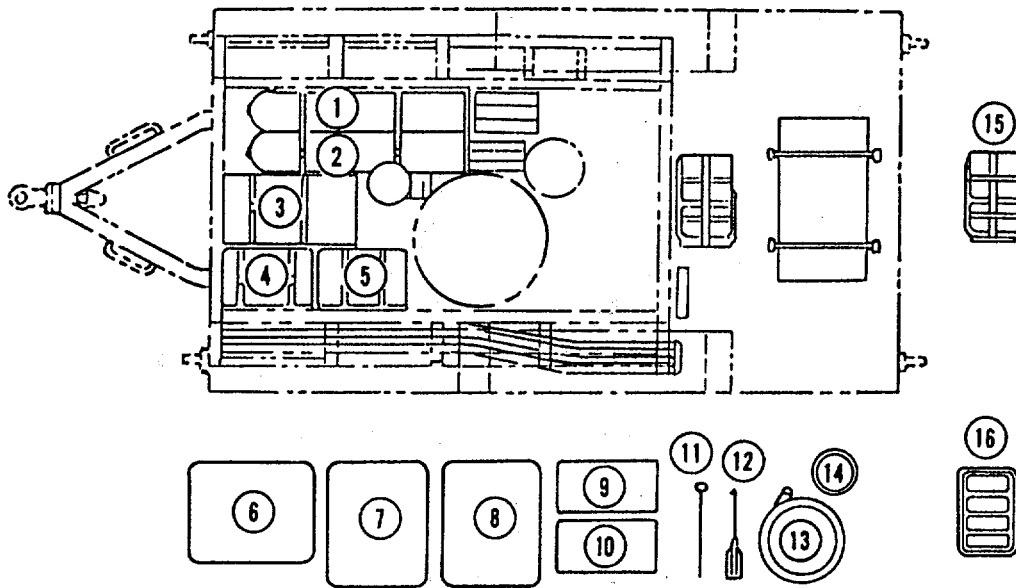

- | | | |
|-------------------|-----------------------|-------------------------------------|
| 1. NBC TANK | 7. PRODUCT WATER TANK | 12. PADDLE |
| 2. NBC TANK | 8. PRODUCT WATER TANK | 13. SUCTION HOSE |
| 3. BACKWASH PUMP | 9. STORAGE BOX | 14. PAILS |
| 4. RAW WATER PUMP | 10. STORAGE BOX | 15. DISTRIBUTION PUMP |
| 5. RAW WATER PUMP | 11. SLEDGE HAMMER | 16. CHEMICAL FEED
CONTAINER/RACK |
| 6. BRINE TANK | | |

FIGURE 2-21. TOP VIEW OF ROWPU AND OVERPACK

NOTE

Only two storage boxes exist. They are Storage Box No. 2 and Storage Box No. 3.

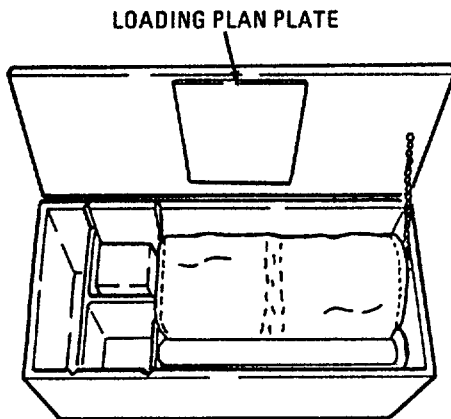

FIGURE 2-22. STORAGE BOX NO. 2

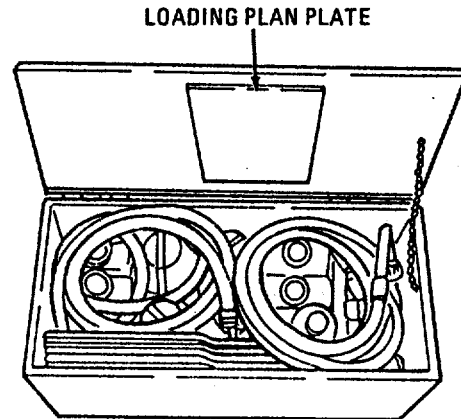

FIGURE 2-23. STORAGE BOX NO. 3

(4) Inspect storage boxes to ensure they contain all items as listed in Appendix B.

(5) Release holddown straps over the two raw water pumps (1). Remove canvas covers. Lift both raw water pumps off the ROWPU.

WARNING

To avoid injury, get help to lift backwash pump.

(6) Release straps over the backwash pump (3) and remove cover. Remove pump from ROWPU.

(7) ARMY) The distribution pump (2) is fastened to the rear platform of the ROWPU trailer. It is packaged for two men to carry (portable). Release hold-down straps, remove the ladder and canvas cover, then remove the distribution pump from trailer.

(8) (MC and AF) The distribution pump (2) is packaged for two men to carry (portable), and is separate from unit. Remove packing material and canvas cover from pump.

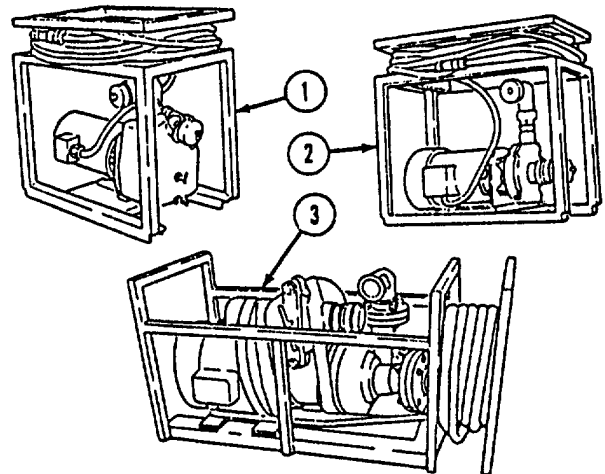

FIGURE 2-24. OUTBOARD PUMPS

NOTE

The total dissolved solids (TDS) meter is factory calibrated to give conductivity characteristics closely representing natural fresh waters. When treating seawater and brackish water, it will be necessary to recalibrate the meter (paragraph 2-15c(2) or paragraph 2-15c(3) in order to get accurate readings on the product water and raw water.

(9) Open the chemical storage box (box No.2). Take out the calibrated measuring container (sample beaker) and the TDS meter.

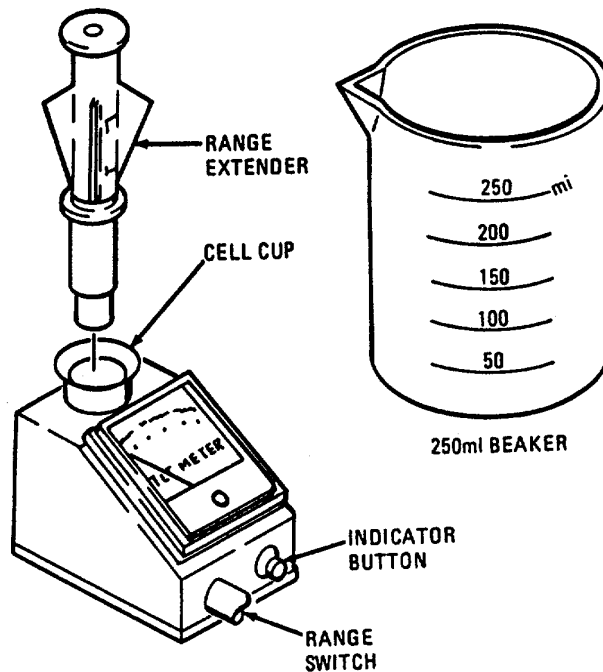

FIGURE 2-25. TOTAL DISSOLVED SOLIDS (TDS) METER

NOTE

This in-line TDS monitor is factory calibrated to give conductivity characteristics closely representing seawater and brackish water. This monitor cannot be recalibrated in the fluid. When treating natural fresh water, the TDS reading will not be accurate, but may be used for comparison purposes.

(10) Remove in-line TDS monitor from storage box No. 3. Carefully unpack and install on control panel (figure 2-26) by sliding into brackets. Secure with pin. Connect each plug in proper receptacle.

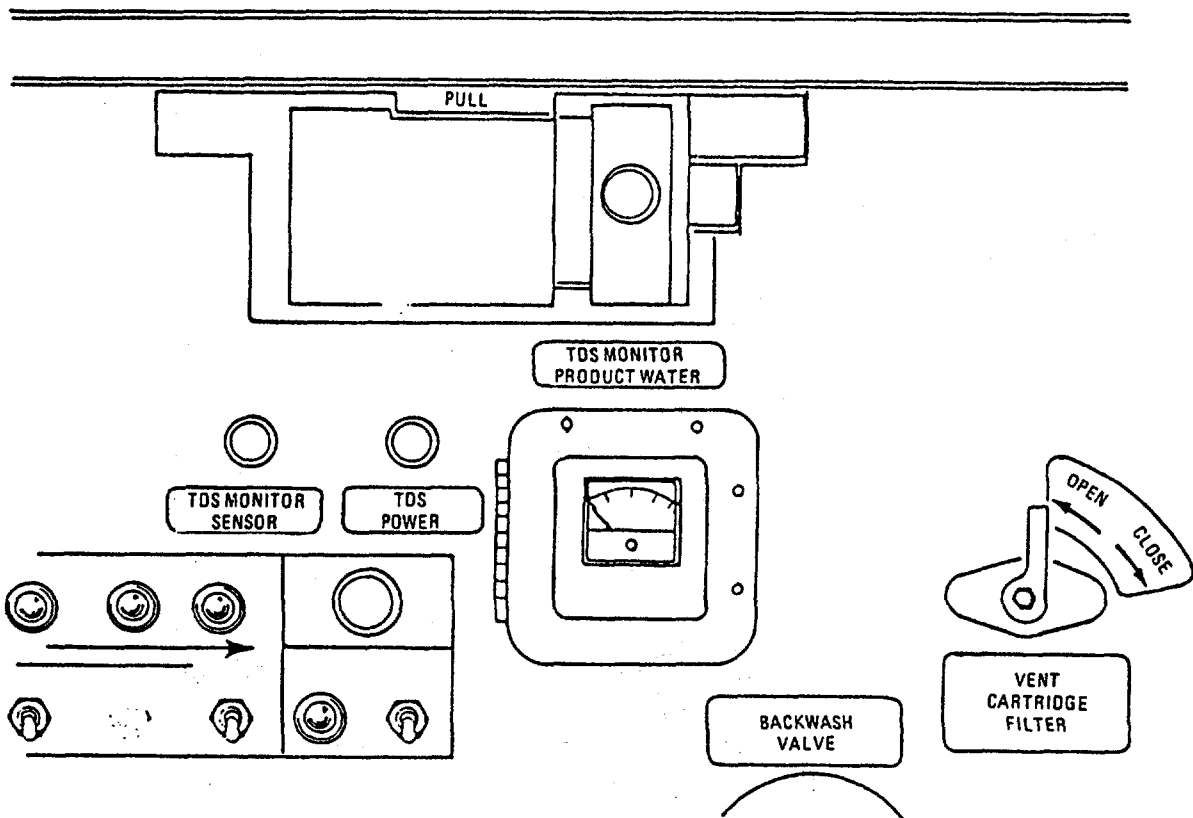
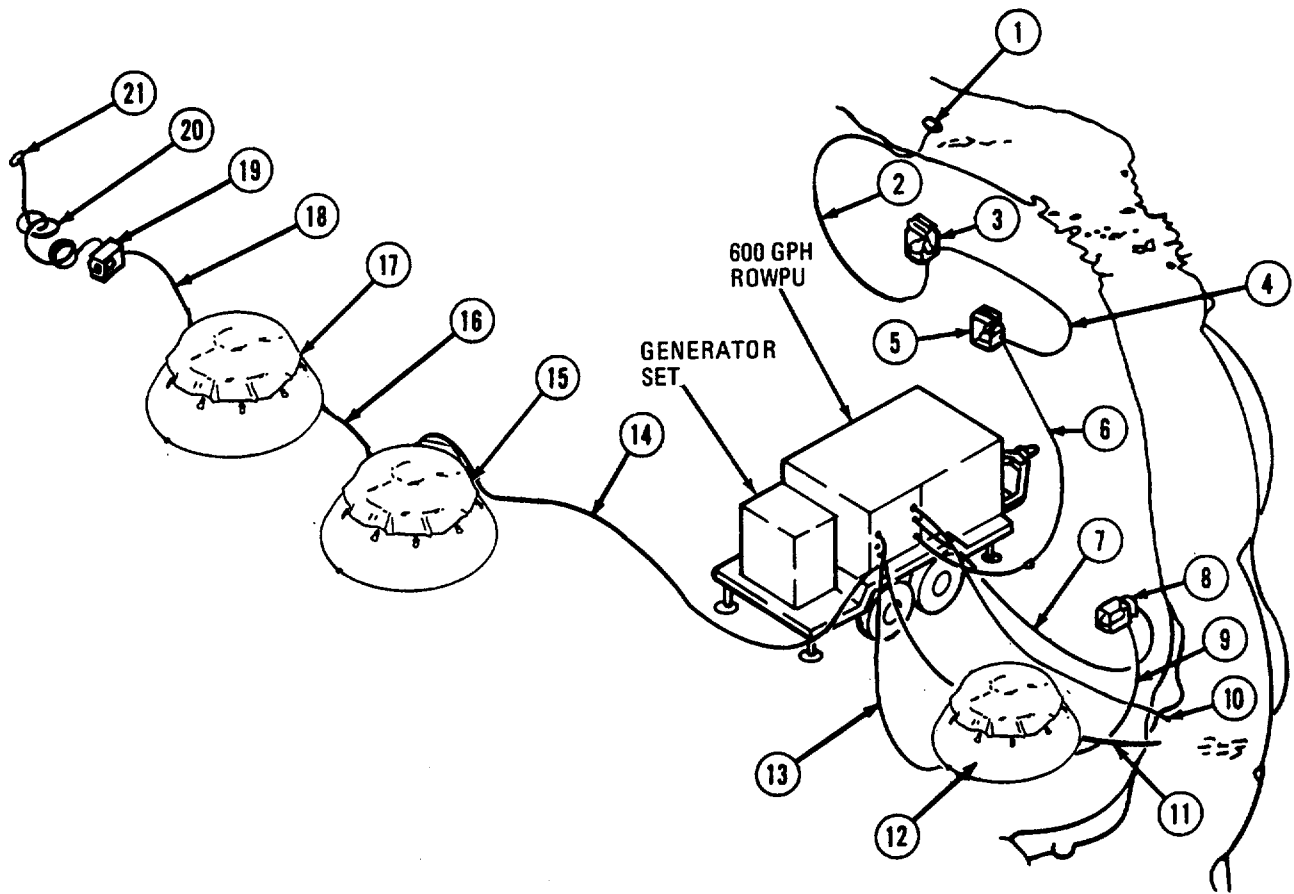

FIGURE 2-26. TDS MONITOR LOCATION

(11) Position operational equipment as shown in figure 2-27 before starting initial installation.

CAUTION

Avoid kinking or excessive looping of hoses.



NOTE

Illustration denotes ARMY model. MC and AF units are skid-mounted.

FIGURE 2-27. TYPICAL FIELD INSTALLATION

- | | |
|--|---|
| 1. Float and strainer | 12. Brine water tank |
| 2. Three 1 1/2 inch suction hoses | 13. Brine 1 1/2-inch discharge hose |
| 3. Raw water pump | 14. Two 1 1/2-inch suction hoses |
| 4. Two 1 1/2 inch suction hoses | 15. Product water tank |
| 5. Raw water pump | 16. Product water 1 1/2-inch suction hose |
| 6. Three 1 1/2 inch discharge hoses | 17. Product water tank |
| 7. Backwash discharge hose (2-inch) | 18. Product water 1 1/2-inch suction hose |
| 8. Backwash pump | 19. Distribution pump |
| 9. Backwash 2-inch hard rubber hose | 20. Product water 1 1/2-inch canvas hose |
| 10. Waste water 2-inch discharge hose | 21. Distribution nozzle |
| 11. Vent vessels discharge hose (2-inch) | |

(12) Refer to TM 5-5430-227-12&P for set-up, operation and maintenance of the 3,000 gallon self-supporting water tank.

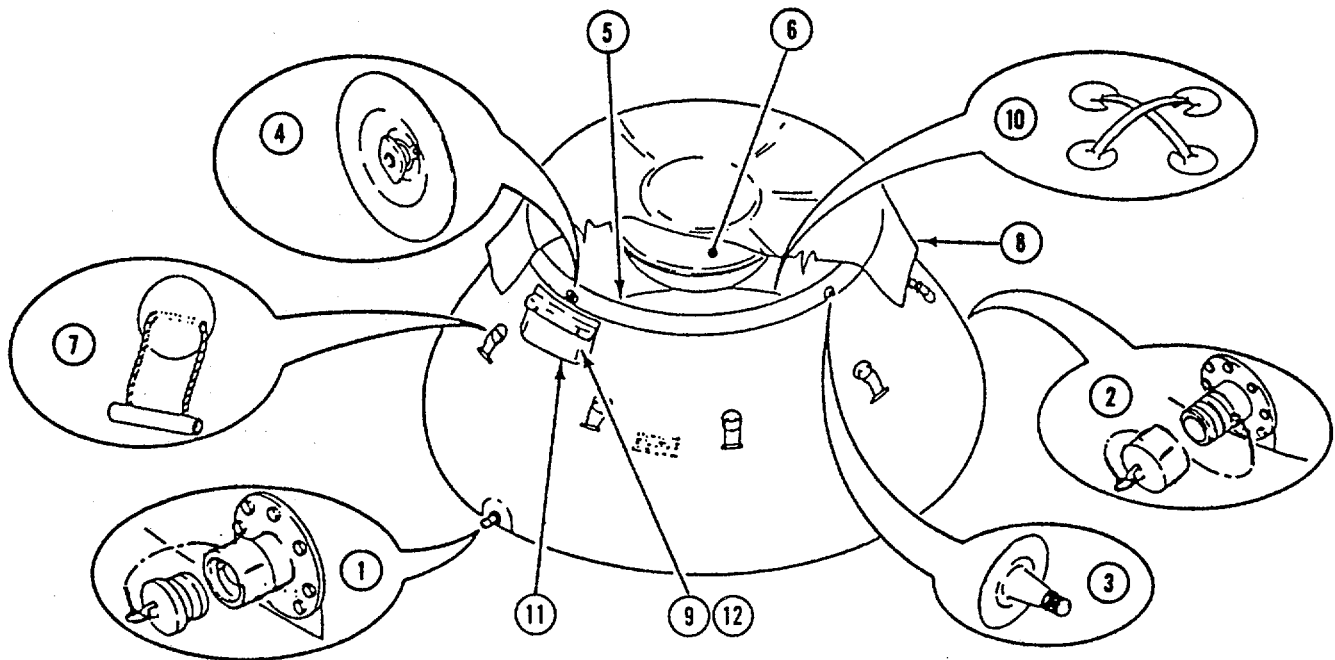

(INSIDE POUCH)

- | | | |
|----------------------|-------------------|------------------|
| 1. FILLER FITTING | 5. TANK COLLAR | 9. FOOT BELLOWS |
| 2. DISCHARGE FITTING | 6. COVER FLOAT | 10. LEFT-HANDLES |
| 3. AUTOMOTIVE VALVE | 7. HANDLE-TOGGLES | 11. REPAIR POUCH |
| 4. INFLATION VALVE | 8. COVER | 12. REPAIR KIT |

FIGURE 2-28. 3,000 GALLON SELF-SUPPORTING WATER TANK

(13) Attach float to strainer with enough rope to allow strainer to go under water but not touch bottom. Avoid placing the strainer near sandy areas. Hook up raw water system (figure 2-29). Use only enough hose to reach from the water source to the ROWPU.

CAUTION

Ensure all hose connections are tight and seals are in place. Raw water pumps will not prime if the raw water hoses draw air. To prevent damage to ROWPU due to leaves and dirt, DO NOT operate pumps without strainer.

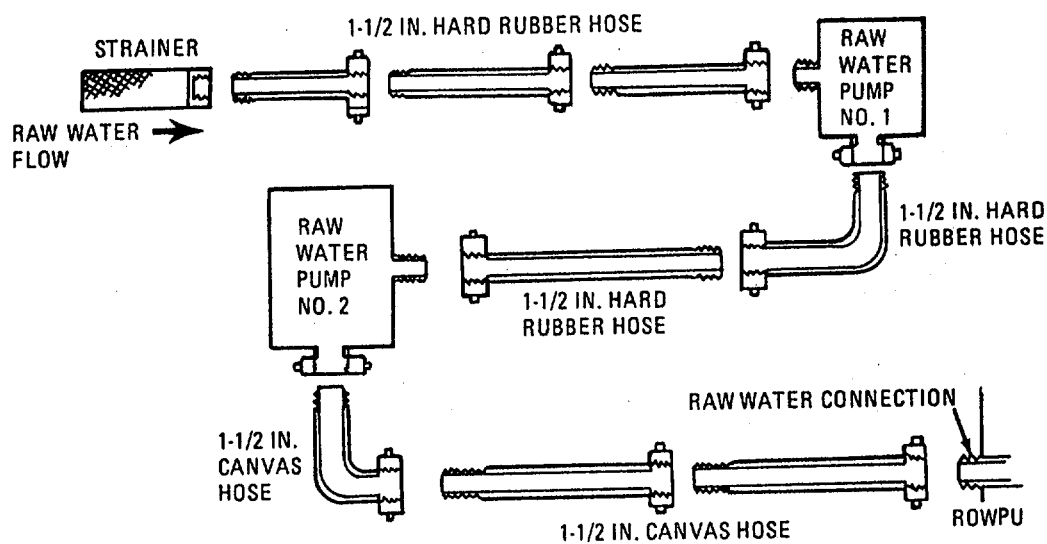

FIGURE 2-29. RAW WATER SYSTEM

- (14) Install backwash strainer onto the backwash pump frame (figure 2-30) as follows:
- (a) Remove straps securing strainer to backwash pump.
 - (b) Remove the two mounting bolts, nuts and washers from the backwash strainer bracket.
 - (c) Remove caps from strainer and pump outlets.
 - (d) Attach strainer inlet connection to swivel connector on backwash pump.
 - (e) Place backwash strainer bracket against the frame and line up the holes.
 - (f) Insert two bolts into mounting holes, placing washers and nuts as required.
 - (g) Tighten all connections.

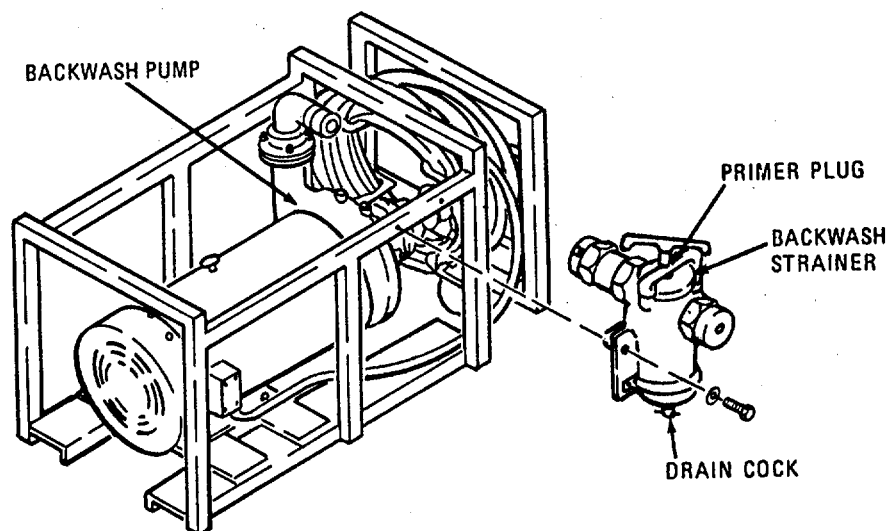

FIGURE 2-30. BACKWASH PUMP AND STRAINER

(15) (See figure 2-31) Using spanner wrench, connect the backwash water tank hose to suction side of backwash pump. Connect backwash water line to discharge side of backwash pump. Start at the ROWPU and work toward the tank in making connections.

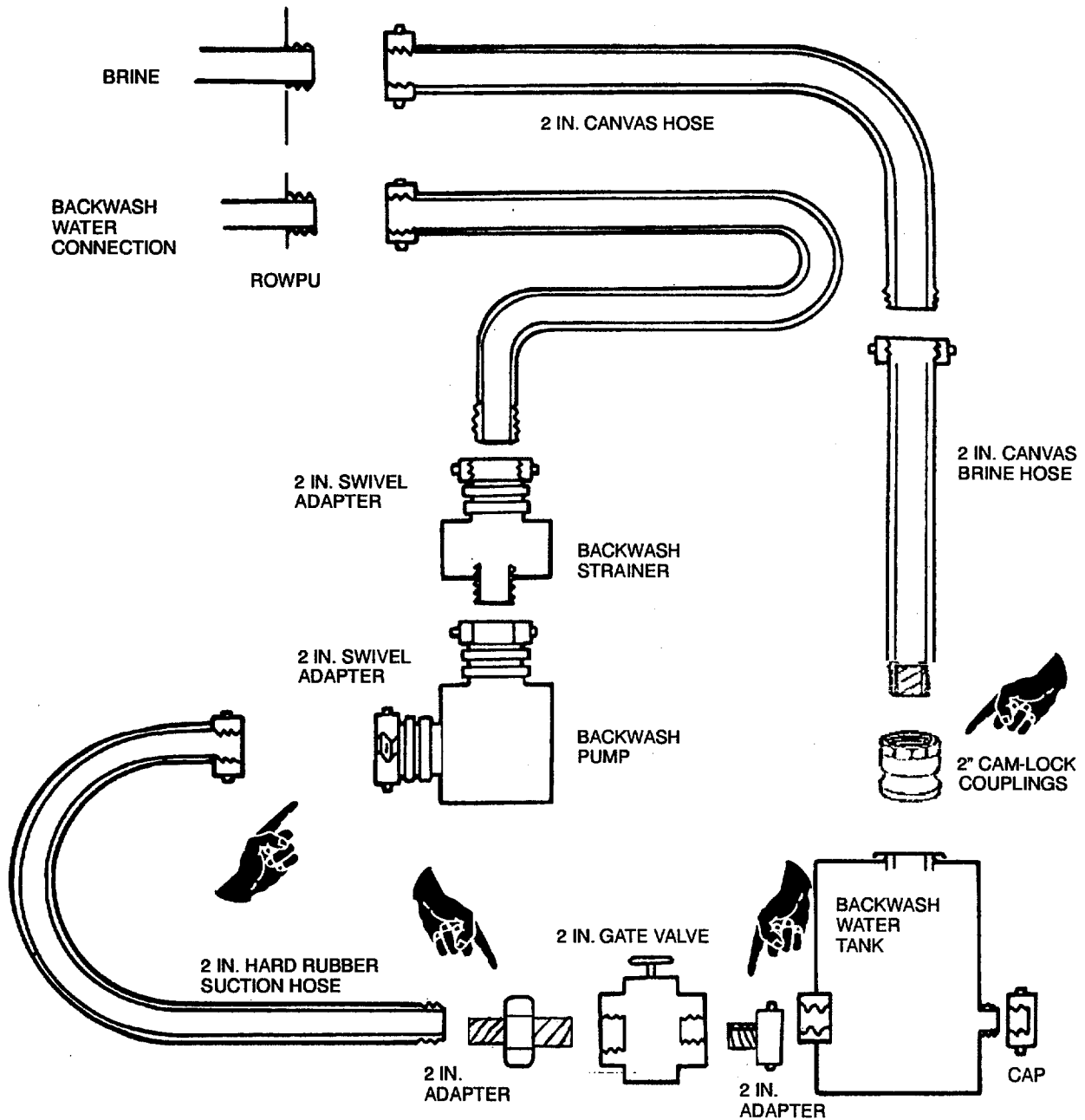

FIGURE 2-31. BACKWASH WATER SYSTEM

(16) Attach product water system hose (figure 2-32), working backwards from the distribution nozzle until last connection is made at the ROWPU.

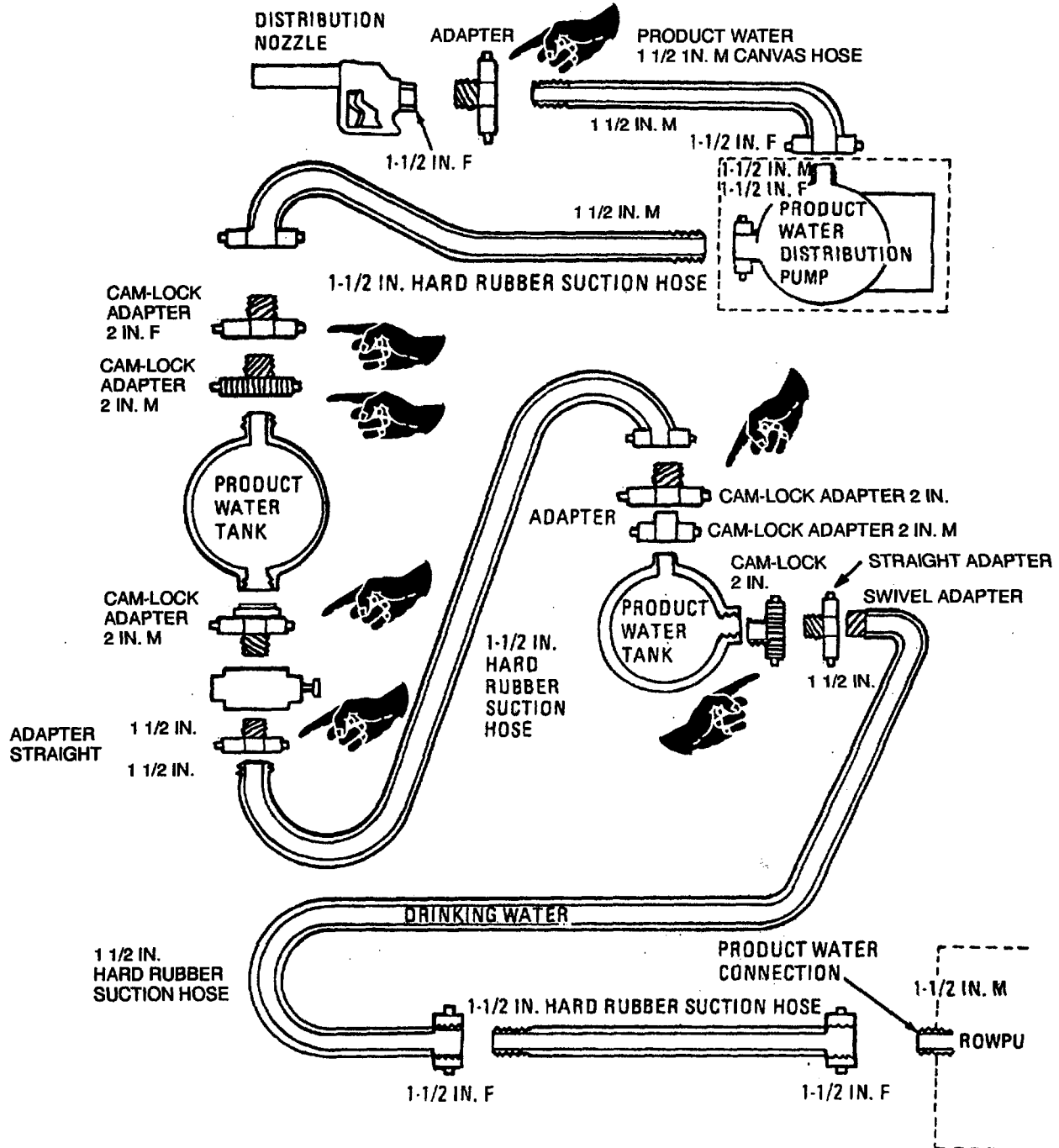

FIGURE 2-32. PRODUCT WATER SYSTEM

(17) Using spanner wrench, hook up waste water and vent vessels systems (figure 2-33). Start at ROWPU with hose going down and away from ROWPU, ending well downstream of raw water intake.

CAUTION

Hold VENT VESSELS valve from turning while tightening pressure hose. Recheck all hose connections to make sure they are tight.

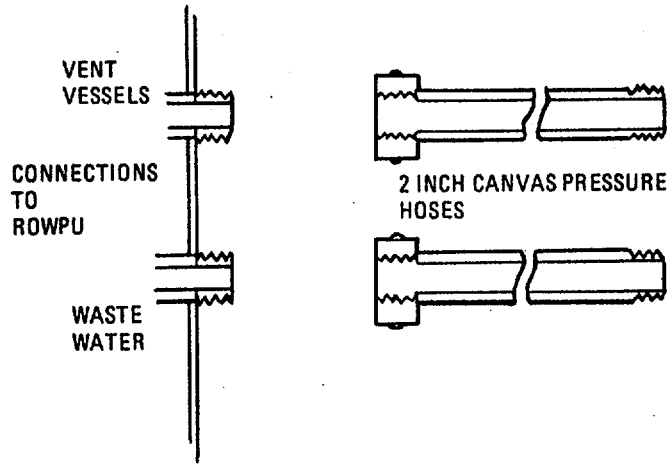

FIGURE 2-33. WASTE WATER SYSTEM

(18) Wood Paddles and Chemical Tube Assemblies.

- (a) Open Storage box No. 3 (figure 2-34) and remove the wood paddles and four sets of chemical tube assemblies.
- (b) Examine tube assemblies. They must be open and clean.
- (c) Check strainers. Ensure they are free of debris. Must be tightly fastened to tubes.

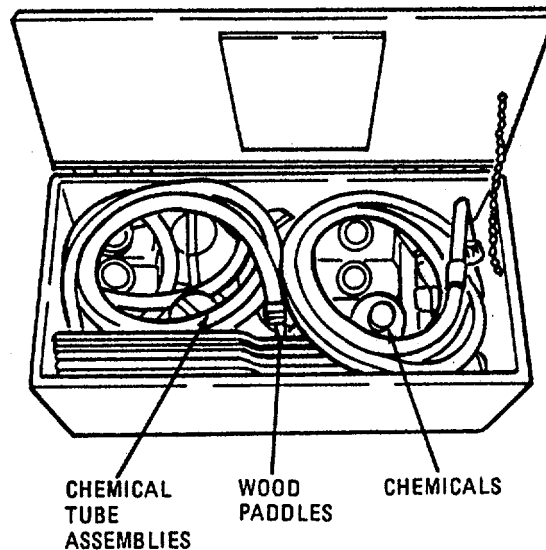

FIGURE 2-34. WOOD PADDLES AND CHEMICAL TUBE ASSEMBLIES

(19) Connect chemical feed tubes to chemical feed containers as follows (see figure 2-35):

- (a) Blue tube to POLYMER.
- (b) Green tube to SODIUM HEX.
- (c) Red tube to CHLORINE.
- (d) Yellow tube to CITRIC ACID.

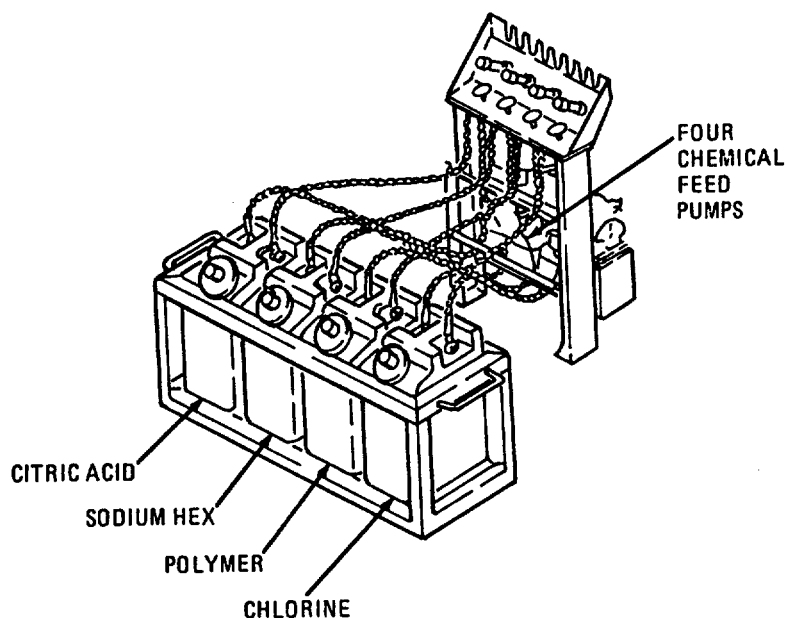

FIGURE 2-35 TUBES ATTACHED TO CHEMICAL FEED PUMPS

WARNING

Chemicals used for operating ROWPU can kill you. The chemicals alone or in mixture can be dangerous. ALWAYS wear protective clothing and make sure area is well ventilated.

CAUTION

Use only chlorine free water for mixing to prevent damage to ROWPU membranes. If this is the first time the ROWPU is being started, use raw water to mix chemicals. If you are restarting the unit, use brine from storage tank.

(20) Mix polymer chemical as follows:

- (a) Fill 107 ml measure HALF-FULL, with liquid polymer chemical (there is no half-full mark on measure).
- (b) Mark one pail for use with polymer. Pour liquid chemical into POLYMER pail.
- (c) Add brine (if available) or raw water up to the 3-gallon mark.
- (d) Stir with wooden paddle for at least a minute (f) Pour solution into 5 gallon chemical container marked POLYMER.

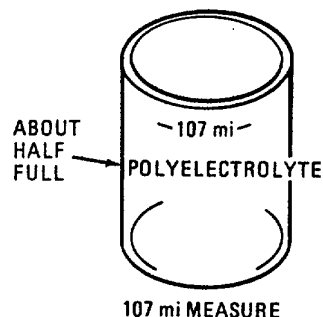

WARNING

Mark one pail for chlorine use only. DO NOT use for other chemicals.

(21) Mix chlorine solution as follows:

- (a) Mark one pail for use with chlorine. Pour 3 gallons of brine into unmarked pail.
- (b) Fill CALCIUM HYPOCHLORITE measure with 0.2 pounds (91 grams) of calcium hypochlorite.
- (c) Pour calcium hypochlorite into pail marked CHLORINE.
- (d) Pour brine (if available) or raw water from unmarked pail into CHLORINE pail.
- (e) Stir with wooden paddle for 1 minute.

NOTE

Mixing calcium hypochlorite with water produces a chlorine solution. It is normal to see white particles in the solution.

- (f) Pour solution into 5 gallon chemical container marked CHLORINE.

CAUTION

Make sure all hose connections are secure on chemical pump, valves and containers.

(22) Mix sodium hexametaphosphate (sodium hex) as follows:

- (a) Pour 0.1 pounds (45 grams) of sodium hex into SODIUM HEX measure.
- (b) Mark one pail for use with sodium hex solution.
- (c) Put sodium hex into pail marked SODIUM HEX.
- (d) Add brine (if available) or raw water to pail marked SODIUM HEX. Fill to the 3-gallon mark.
- (e) Stir with wooden paddle for 1 minute.
- (f) Pour solution into 5 gallon chemical container marked SODIUM HEX.

(23) Mix citric acid as follows:

NOTE

Perform this step only if ROWPU will be operated 20 or more hours before changing sites. Otherwise, proceed to step (24).

- (a) Mark one pail for use with citric acid.
- (b) Pour three quarter pounds (340 grams) of citric acid into pail marked CITRIC ACID.
- (c) Add brine (if available) or raw water to pail marked CITRIC ACID. Fill to the 3-gallon mark.
- (d) Stir with wooden paddle for 1 minute.
- (e) Pour solution into 5 gallon container marked CITRIC ACID.

(24) Check chemical solution container levels by loosening the cap on the indicator, and then gently letting go. Indicators should remain raised approximately 1/4 the length of the indicator (1/4 full).

WARNINGS

ELECTRICAL HIGH VOLTAGE CAN KILL YOU

- Electrical high voltage cannot be seen but it can kill you. Electricity is unlike most other dangerous things you can come in contact with because it gives no warning and no symptoms to be wary of. Its effect is immediate. It can kill you, render you unconscious, or severely burn you. To ensure your safety and that of other maintenance personnel, always observe the following precautions:

ALWAYS make sure the unit is properly grounded.

- Extreme care must be taken to prevent injury to fingers or hands when driving the ground rods. Do not place hands between the ram and drive collar. Gloves should be worn. Be sure all connections are tight so as to avoid a possible spark between the units and ground rod.

(25) Ground the ROWPU with ground rod kept on outside bottom of the control panel (figure 2-36) as follows:

(b) Remove the ground rod section rod with the bolt screwed into the coupler. The bolt keeps from damaging the coupler when the rod is driven into the ground.

(b) Drive the first 3-foot section into the ground with the 8-pound hammer, or use the slide hammer.

NOTE

If driving gets too hard, soak the earth and try driving rod until 8 feet of rod is in the ground. If this does not work initially, continue alternately soaking ground and driving rod. If unable to get 8 feet of rod into the soil, then keep soil moist around the rod for the duration of the operation.

(c) When the first rod coupler is about 6 inches above ground, remove the driving bolt. Screw a new length of ground rod into the one already in the ground and drive it in as with the first section. Continue until there are 8 feet of rod in the ground.

(d) When done with driving the ground rod, connect the rod sticking out of the earth to the GROUND lug located on the ROGEN frame immediately below the ROWPU electrical cable connections. Use the ground strap provided.

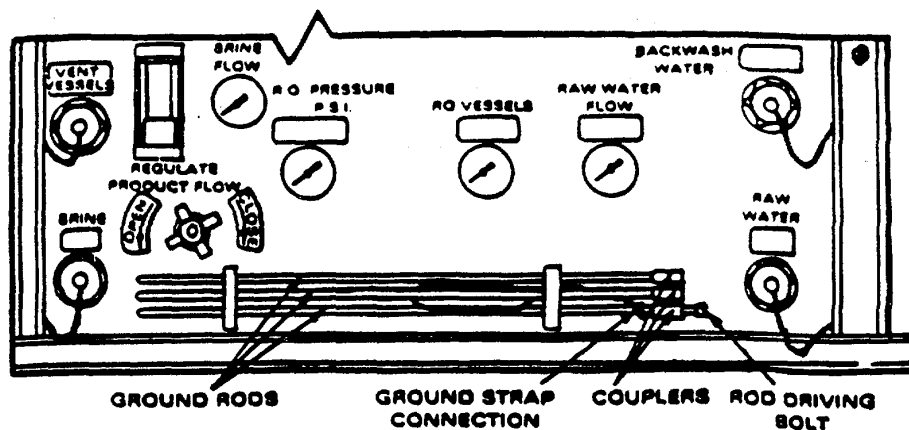

FIGURE 2-36. GROUND RODS IN STOWED POSITION

(26) Unwind the power cables of each pump. Pull the cables to the ROWPU junction box and unscrew the covers of the connectors. Attach pump cables to the connectors shown in figure 2-37. Plug the power cable from the power source into J1, if not already installed. (Army, MC only)

2-7. INITIAL ADJUSTMENTS AND CHECKS.

a. Drain Valves. Close all drain valves. Drain valves must remain closed at all times during operation.

NOTE

You will find all seven drain valves to the left front of the ROWPU as shown.

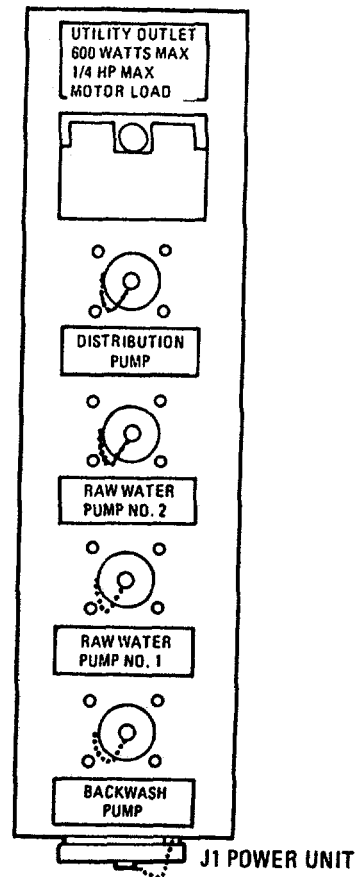

FIGURE 2-37. JUNCTION BOX

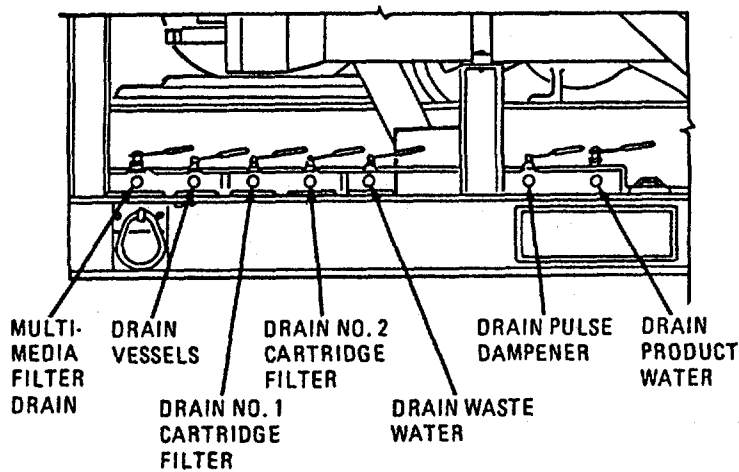

FIGURE 2-38. DRAIN VALVES (DURING OPERATION)

b. Vent Valves. Open all five vent valves as listed below. Three are on the control panel, one is behind the panel and one is to the right of the top R.O. vessel.

1. VENT CARTRIDGE FILTER (see figure 2-40)
2. VENT PULSE DAMPENER (see figure 2-40)
3. VENT MULTIMEDIA FILTER (see figure 2-40)
4. VENT VESSELS (see figure 2-5)
5. VENT PRODUCT WATER (see figure 2-39)

NOTE

The fifth vent valve, the VENT PRODUCT WATER valve, is located on top of product water manifold.

NOTE

THE FIFTH VALVE, THE VENT PRODUCT WATER VALVE, IS LOCATED ON TOP OF PRODUCT WATER MANIFOLD.

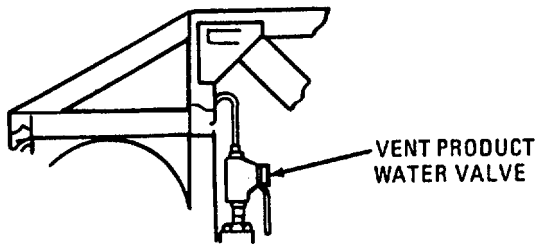

FIGURE 2-39. VENT PRODUCT WATER VALVE

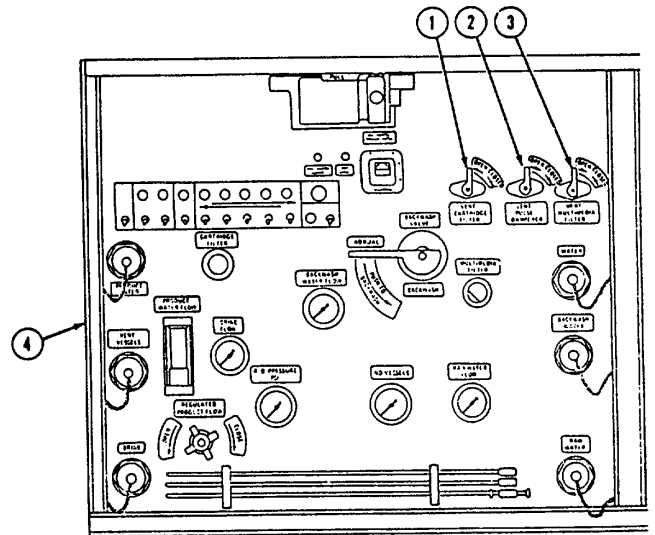

FIGURE 2-40. VENT VALVES

c. R.O. Vessel Sample and Vent Valves. Close four R.O. vessel sample valves located at forward end (R.O. pump end) of each R.O. vessel. Close four R.O. vessel vent valves located at rear of each R.O. vessel. Vent and sample valves are connected to the R.O. vessels by clear, braided plastic hose.

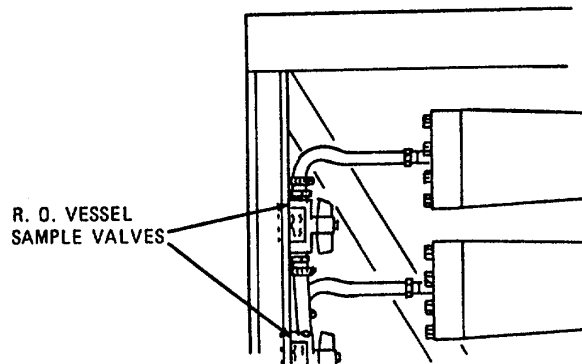

FIGURE 2-41. R.O. VESSEL SAMPLE VALVES (TYPICAL)

d. Backwash Valve. Set the backwash valve to normal.

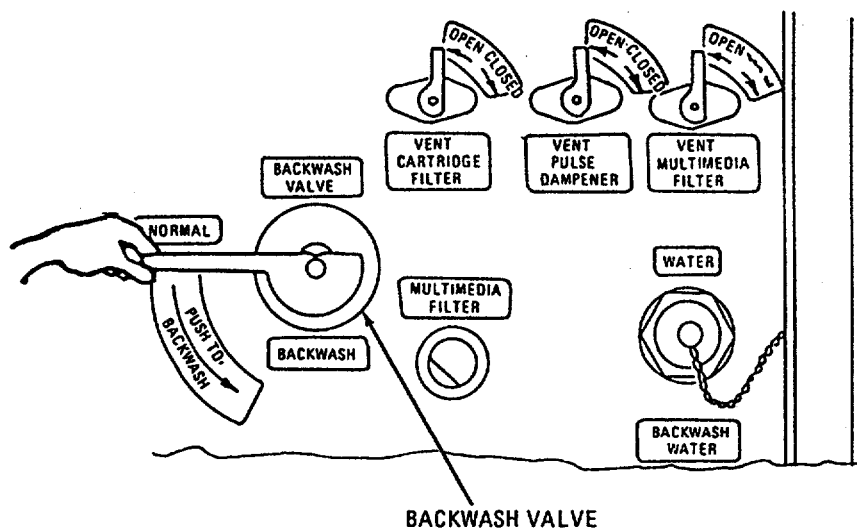

FIGURE 2-42. BACKWASH VALVE

e. Regulate Product Flow Valve. Turn the REGULATE PRODUCT FLOW VALVE handle fully counterclockwise to the open position.

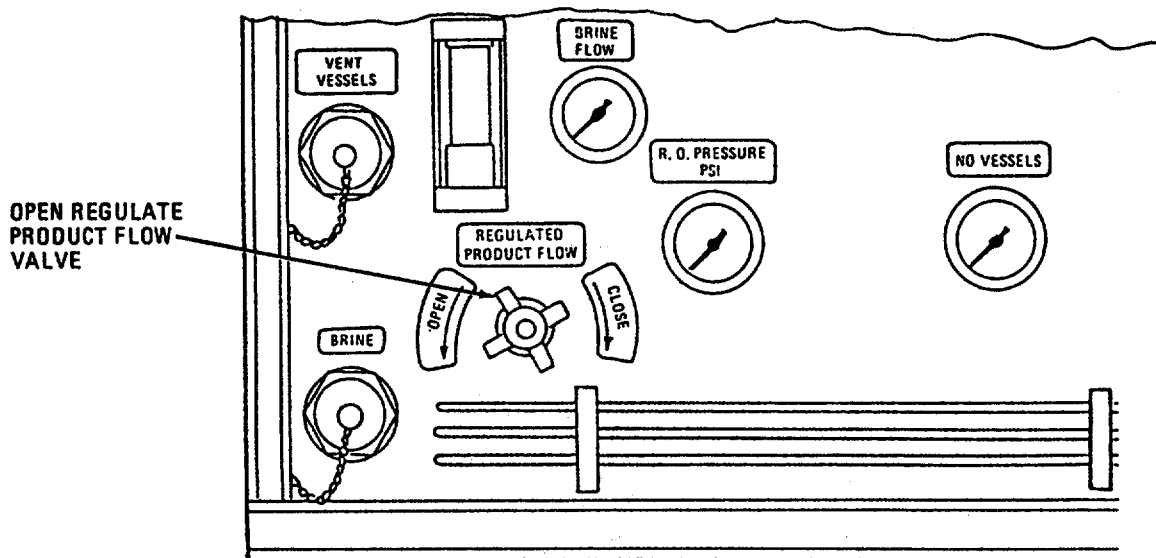

FIGURE 2-43. PRODUCT FLOW VALVE

f. Control Box Switches.

(1) Check switches on the control box assembly. If you find any switch in the RUN position, switch it to STOP, with the exception of the BACKWASH switch that will stay in the RUN position.

NOTE

The switches marked START are spring-loaded. Upon release they return to the middle (RUN) position. The ones marked JOG, RESET, and START BACKWASH return to the normal position when released.

(2) An indicator lamp is associated with each switch except for the EMERGENCY STOP button. Check the setting of the EMERGENCY STOP button. Pull button until it remains out when released. This is the normal operating position.

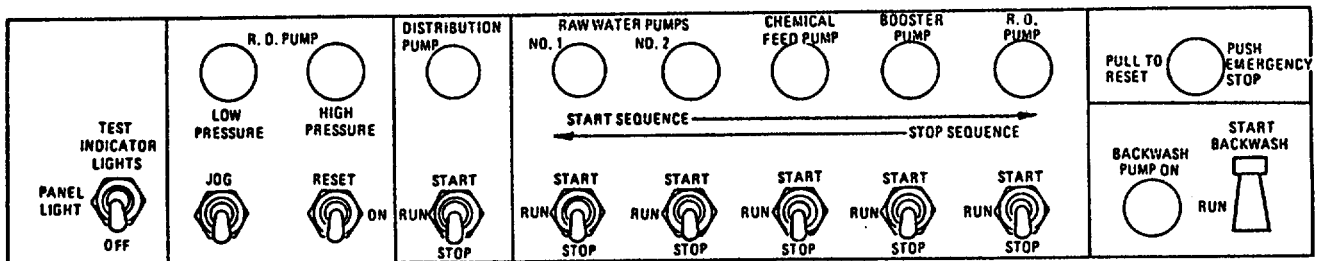

FIGURE 2-44. CONTROL BOX SWITCHES

g. ELEMENT CLEANING Switch. Check that the ELEMENT CLEANING switch is in the OFF position. It should be off at all times except while cleaning R.O. elements (paragraph 2-13).

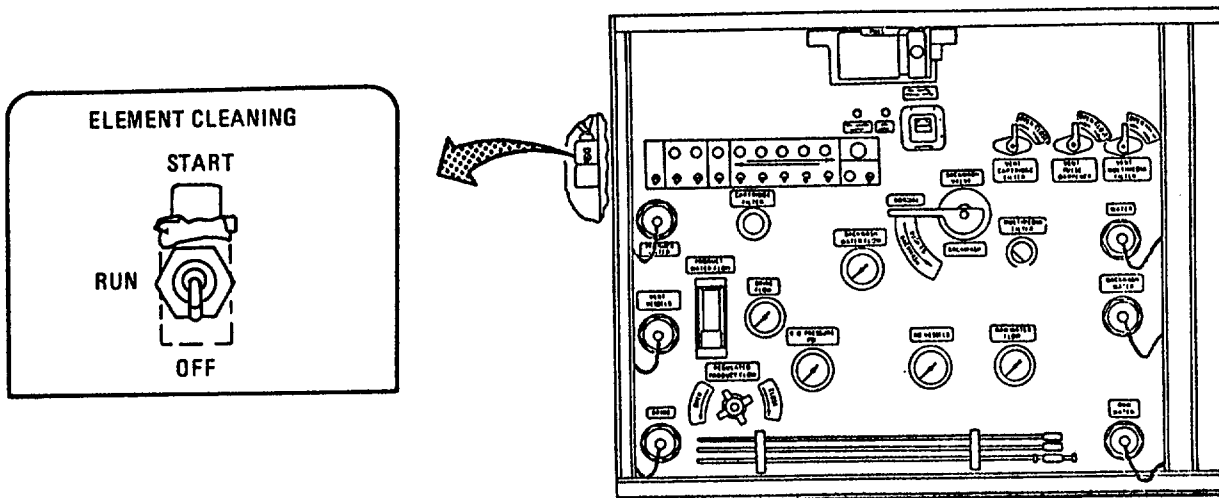

FIGURE 2-45. ELEMENT CLEANING SWITCH

h. Chemical Feed Run/Prime Valves. Ensure all valves are in PRIME position (figure 2-10).

i. Backwash Timer. Do not press RESET button on subpanel. Reset should only be pressed if malfunction has occurred. Refer to troubleshooting table.

j. Raw Water Pump Valves.

(1) Take an unmarked pail and an adjustable wrench to the source of water. Check suction hoses in raw water to make sure strainer is under water. With the pail, draw some raw water from the source. Take it to raw water pump closest to the raw water supply.

(2) Close drain and vent valves.

(3) Remove priming plug with your wrench. Fill pump with raw water. Screw priming plug back into pump. Return adjustable wrench to tool case.

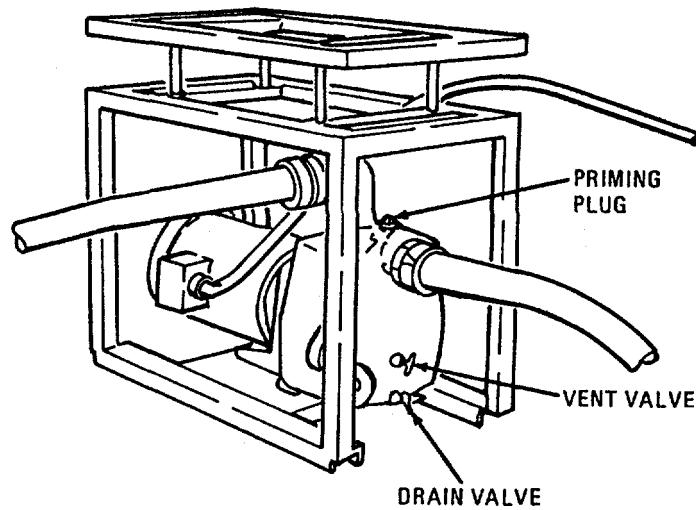

FIGURE 2-46. RAW WATER PUMP (PRIME, DRAIN AND VENT VALVE)

2-8. SAFETY DEVICES.

The ROWPU has automatic safety devices: the high pressure relief valve, the high pressure switch, and the rupture disc assembly.

a. High Pressure Relief Valve. The high pressure relief valve is located just behind the VENT VESSEL VALVE. If R.O. pressure goes above 1 100psi, this valve opens automatically and discharges water through a pipe at the back of the ROWPU. If this valve activates (indicated by sudden pressure loss), immediately press the PUSH EMERGENCY STOP switch. Open REGULATE PRODUCT FLOW VALVE after unit is shut down. When the pressure drops below 1 100 psi, the valve will close automatically.

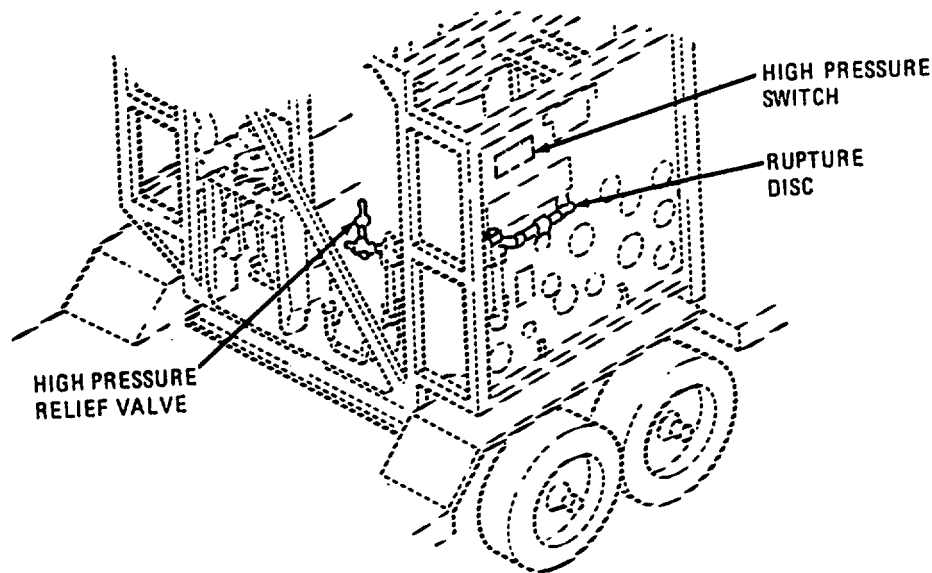

FIGURE 2-47. HIGH PRESSURE RELIEF VALVE, HIGH PRESSURE SWITCH AND RUPTURE DISC

CAUTION

If the valve does not close automatically, notify unit maintenance and do not try to restart the ROWPU.

After the high pressure relief valve closes, clean the R.O. elements (see paragraph 2-12) and start the ROWPU in the normal manner (paragraph 2-9).

b. High Pressure Switch. The high pressure switch is mounted to the rear of the front panel adjacent to the PANEL LIGHT. The high pressure switch activates above 1250 psi. If the HIGH PRESSURE SWITCH activates, the R.O. pump will automatically shut down and the HIGH PRESSURE LAMP will come on. When the pressure drops, use the RESET SWITCH to reset high pressure switch. Notify unit maintenance to troubleshoot the HIGH PRESSURE RELIEF VALVE.

c. Rupture Disc Assembly. The rupture disc assembly is located on the pipe between the R.O. PUMP and the pulse dampener. The rupture disc is a thin sheet of metal that tears when the pressure goes above 1425 psi. Water is then discharged through the six holes in the top of the assembly. Because the water is under such high pressure, it will make a lot of noise, and water will be sprayed on the inside of the ROWPU. If the rupture disc assembly ever activates, press the PUSH EMERGENCY STOP switch and open the REGULATE PRODUCT FLOW valve. When the pressure has dropped, replace the rupture disc (see paragraph 3-7) and clean the R.O. elements (see paragraph 2-12). Notify unit maintenance to troubleshoot the high pressure relief valve and the high pressure switch.

2-9. OPERATING PROCEDURES.

a. Apply Electrical Power.

(1) Open junction box cover (figure 1-9) and push circuit breakers CB-1 thru CB-9 (figure 2-4) to on position (up). Pull out EMERGENCY STOP switch (figure 2-48).

(2) Push TEST LAMP switch to check all lights and adjust dimmer knobs.

NOTE

R.O. PUMP LOW PRESSURE lamp on ROWPU control box assembly comes on as soon as power is applied to the ROWPU.

(3) Push EMERGENCY STOP button whenever the following conditions exist:

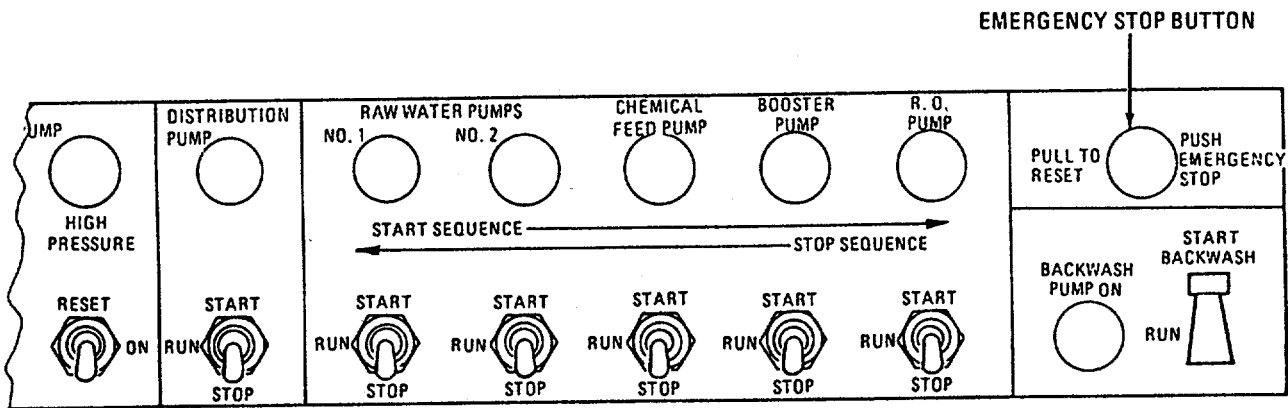

FIGURE 2-48. EMERGENCY STOP BUTTON

WARNING

Operating personnel could be injured or the equipment could be damaged if operation of the ROWPU is allowed to continue.

(a) HIGH PRESSURE lamp associated with R.O. PUMP comes on but R.O. Pump does not automatically stop.

(b) LOW PRESSURE lamp associated with R.O. PUMP comes on but R.O. Pump does not automatically stop.

(c) Some other serious trouble (malfunction) indicated by noise, vibration, large water leaks, etc.

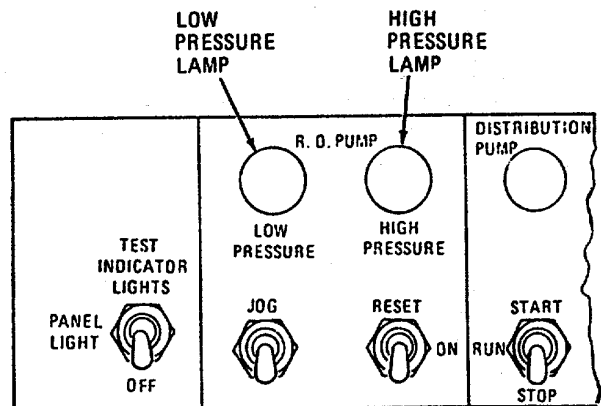

FIGURE 2-49. HIGH/LOW PRESSURE LAMPS

NOTE

If low or high-pressure switches shut down the ROWPU automatically, they can only be reset with the RESET switch. After emergency shutdown, distribution of potable water can still be made by pulling out the EMERGENCY STOP button and running the distribution pump as required.

b. Start RAW WATER PUMP NO. 1.

- (1) Go to control box assembly on the ROWPU. Locate the lamp and switch for RAW WATER PUMP No. 1.
- (2) Set switch upward to START.
- (3) Hold switch up until lamp NO. 1 comes on.
- (4) Release switch.
- (5) Switch will return to RUN.
- (6) Look at output hose from raw water pump No. 1. Hose goes into suction side of raw water pump No.

2. Hose should expand and straighten out.

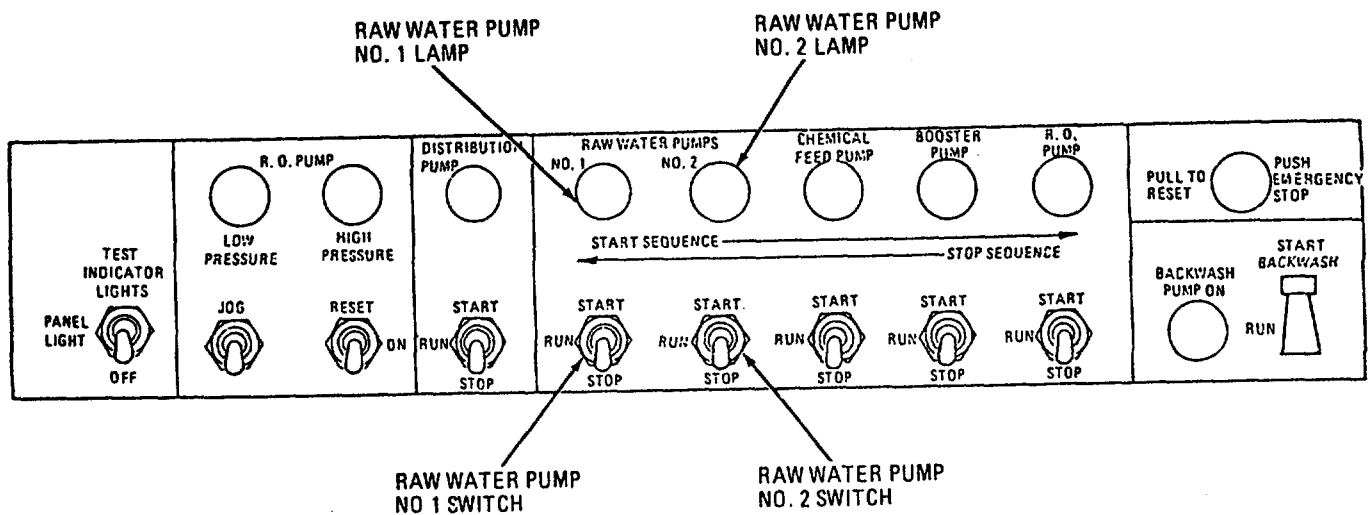

Figure 2-50. Switches (Pump Controls)

c. Start RAW WATER PUMP NO. 2.

(1) Go to control box assembly on the ROWPU. Locate the lamps and switch for RAW WATER PUMP No. 2.

- (2) Set switch upward to START.
- (3) Hold switch until lamp No. 2 comes on.
- (4) Release switch.
- (5) Switch will return to RUN.
- (6) Look at output hose from raw water pump

No.

2. Hose goes into lower right connection of ROWPU control panel. Hose should expand and straighten out.

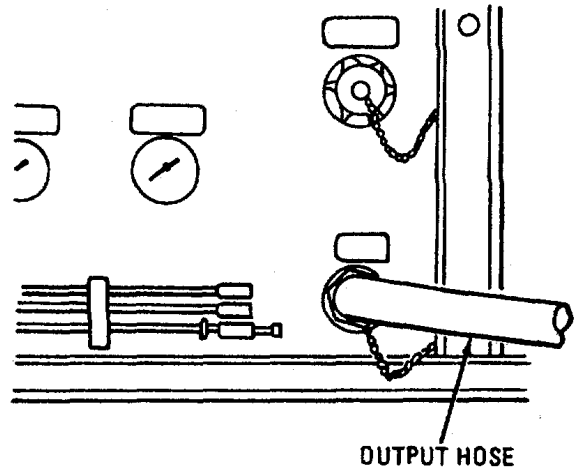

FIGURE 2-51. OUTPUT HOSE- RAW WATER PUMP NO. 2

NOTE

If raw water flow is not between 27-33 gpm, then prime was not established. Set both RAW WATER PUMP switches to STOP. Prime raw water pump No. 1 again (as described above), then restart pumps. Repeat priming if necessary until water starts flowing into the ROWPU.

- (7) Check RAW WATER FLOW gage for 27-33 gpm.

d. Start CHEMICAL FEED Pump.

- (1) Go to control box assembly on the ROWPU. Locate lamp and switch for CHEMICAL, FEED PUMP
- (2) Hold switch at START until lamp above it goes on.
- (3) Release switch. Switch returns to RUN.

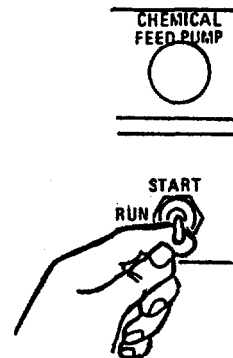

FIGURE 2-52. CHEMICAL FEED PUMP START SWITCH

e. Adjust Chemical Feed Pump.

- (1) Loosen all four control knob thumbscrews.

NOTE

Loosen thumbscrews before adjusting control knobs. After adjustment, tighten thumbscrews to lock control knobs in position.

- (2) Turn all four chemical feed control knobs to their maximum settings (fully clockwise).

NOTE

If pump fails to prime, there may be some particles in the suction or discharge valves. Check Section II, Chapter 3, Troubleshooting.

- (3) With the control knobs set at maximum and RUN/PRIME valves set to PRIME, allow chemical pump motor to run until solution flow has been established in the polymer hoses.

- (4) When solution flow has been established, calibrate the POLYMER flow as follows:

- (a) For noticeably turbid (dirty or murky) source water, set POLYMER control knob to 50. Otherwise, set POLYMER control knob to 35.

- (b) Use the 100-ml graduated plastic cylinder out of Storage Box No. 3.

- (c) While POLYMER pump is running, remove polymer return hose from container and catch flow for 1 minute.

- (d) If knob was set to 50, flow should be about 60ml/min. Otherwise, it should be about 20 ml/min. Adjust knob to obtain correct flow. Record knob setting for future reference.

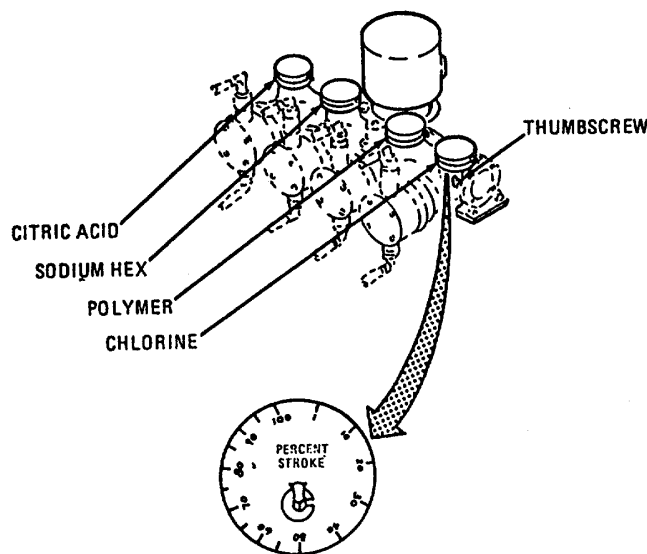

FIGURE 2-53. CONTROL KNOBS

(5) When solution flow has been established in SODIUM HEX and CHLORINE hoses, calibrate the flows as follow:

- (a) Set the SODIUM HEX control knob to 50.
- (b) Remove return hose from chemical container.
- (c) Catch chemical in 100 ml graduated cylinder (Storage Box No. 3).
- (d) Adjust control knob to approximately 60 ml/min flow. Record knob setting for future reference.
- (e) Calibrate chlorine flow in same way.
- (f) Do NOT turn RUN/PRIME valves to RUN; leave them in PRIME position.

(6) Leave CITRIC ACID control knob at maximum setting; no calibration is required for CITRIC ACID flow. RUN/PRIME valve remains in PRIME position throughout normal operation.

(7) With both raw water pumps working, and the chemical feed pump running, set POLYMER pump valve from PRIME to RUN.

f. Vent Multimedia Filter. Vent multimedia filter and check for vent line blockage as follows:

(1) Set VENT MULTIMEDIA FILTER valve, VENT PULSE DAMPENER valve, and VENT CARTRIDGE FILTER valves to CLOSE (figure 2-54).

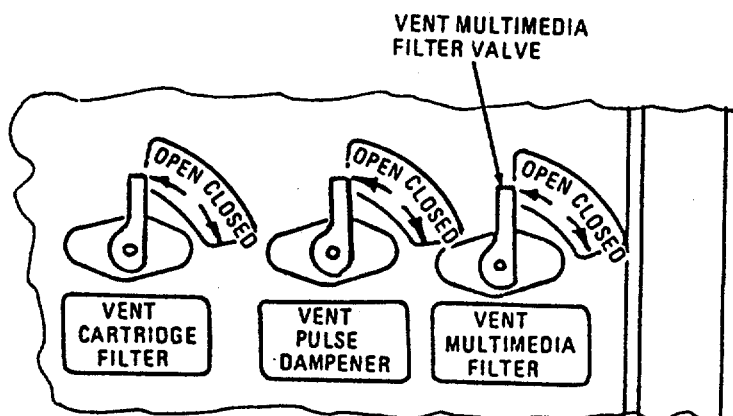

FIGURE 2-54. MULTIMEDIA FILTER VENT VALVE

(2) Set VENT MULTIMEDIA FILTER valve to OPEN.

NOTE

There should be air venting out of the pipe as the multimedia filter fills, followed by a steady stream of water when the filter is full. If not, the vent line is probably blocked by a small piece of filter media. Notify unit maintenance.

(3) Set VENT MULTIMEDIA FILTER valve to CLOSE as soon as a full stream of water flows out of vent pipe (located at bottom right-hand front of trailer, below R.O. pump belt guard).

g. Start Booster Pump.

- (1) Set VENT CARTRIDGE FILTER valve (figure 2-56) to OPEN.
- (2) Hold BOOSTER PUMP switch (figure 2-55) upward to START.
- (3) When lamp comes on, release switch.
- (4) Switch will return to RUN.
- (5) Set VENT CARTRIDGE FILTER valve to CLOSE as soon as a full stream of water flows out of vent pipe (located at bottom right-hand of trailer below R.O. pump screen belt guard).

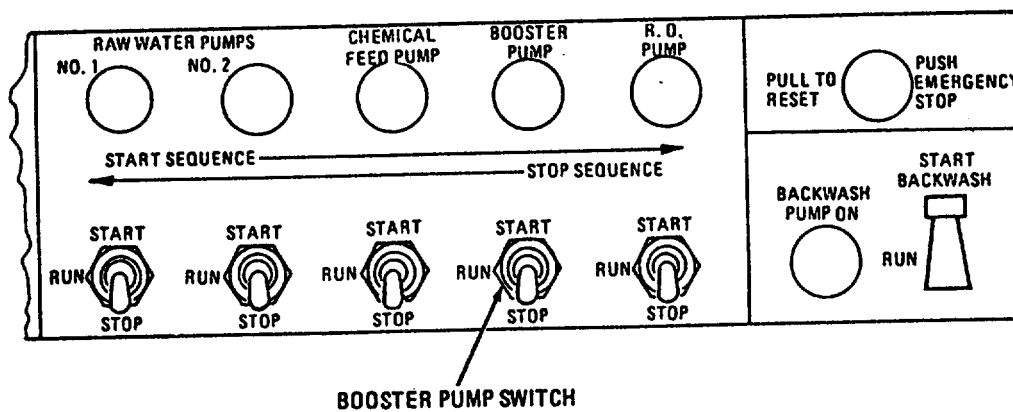

FIGURE 2-55. BOOSTER PUMP SWITCH

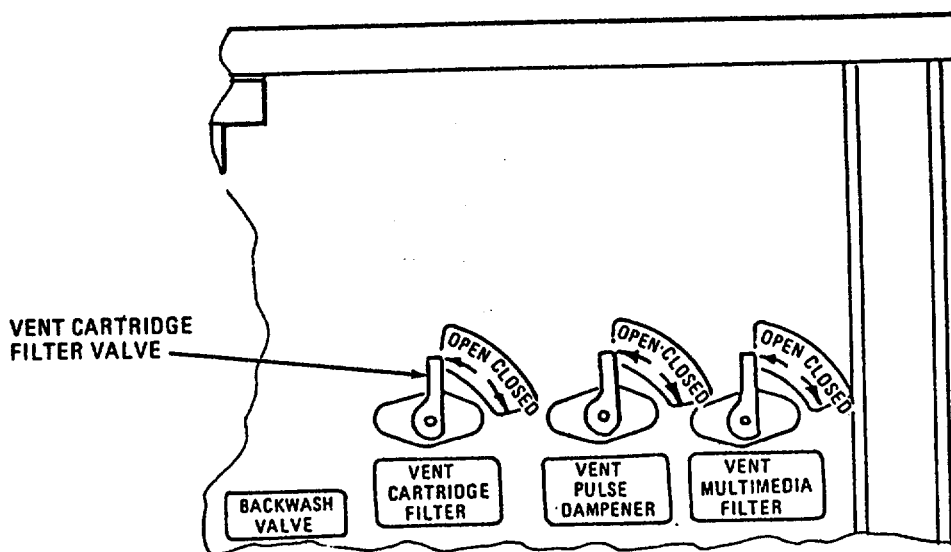

FIGURE 2-56. CARTRIDGE FILTER VENT VALVE

h. Start R.O. Pump.

- (1) Make sure VENT VESSELS VALVE (figure 2-5) is open.

WARNING

To prevent injury to personnel, do not stand in front of the vent pipe when venting pulse dampener.

- (2) Set VENT PULSE DAMPENER valve to OPEN.
- (3) Push R.O. Pump RESET switch upward. R.O. pump LOW PRESSURE lamp goes OFF and switch returns to ON.
- (4) Hold R.O. PUMP switch (figure 2-57) upward to START.
- (5) As soon as R.O. PUMP lamp comes on, release switch.
- (6) Switch will return to RUN.

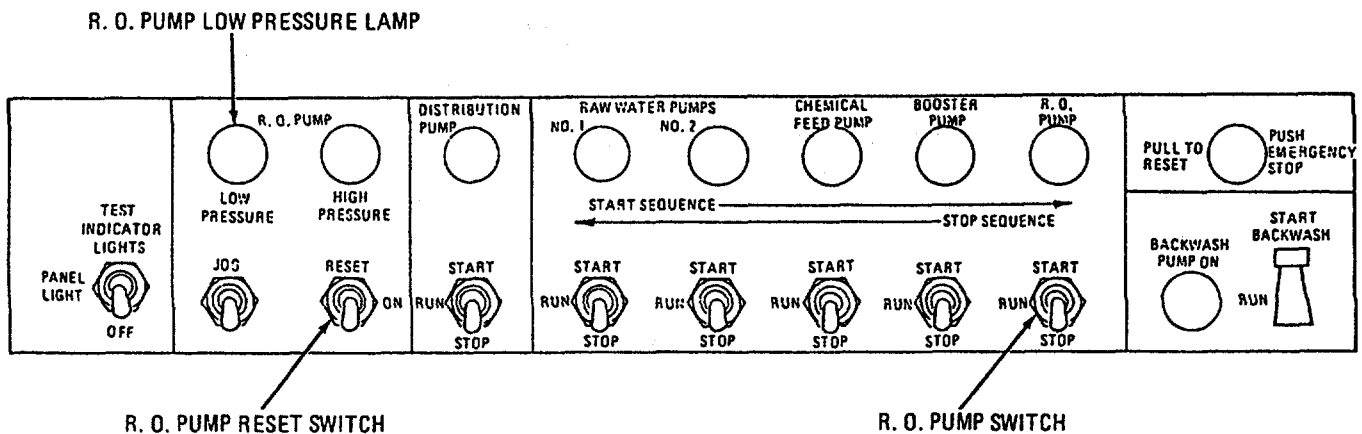

FIGURE 2-57. CONTROLS, R. O. PUMP

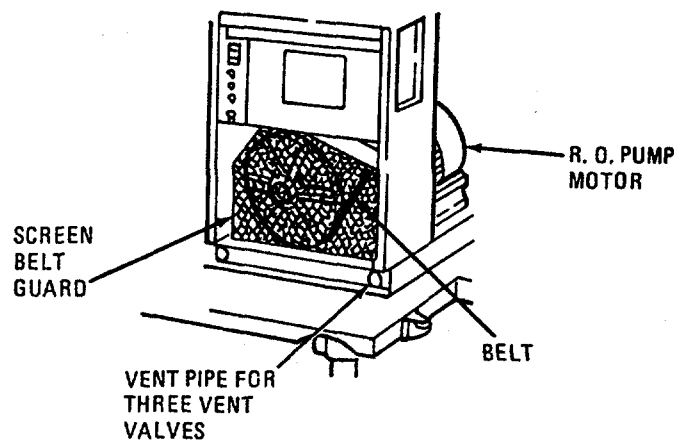

FIGURE 2-58. R. O. PUMP AND MOTOR

- (7) Set the VENT PULSE DAMPENER valve (figure 2-59) to CLOSE as soon as you see a full stream of water coming from the vent pipe (figure 2-58).

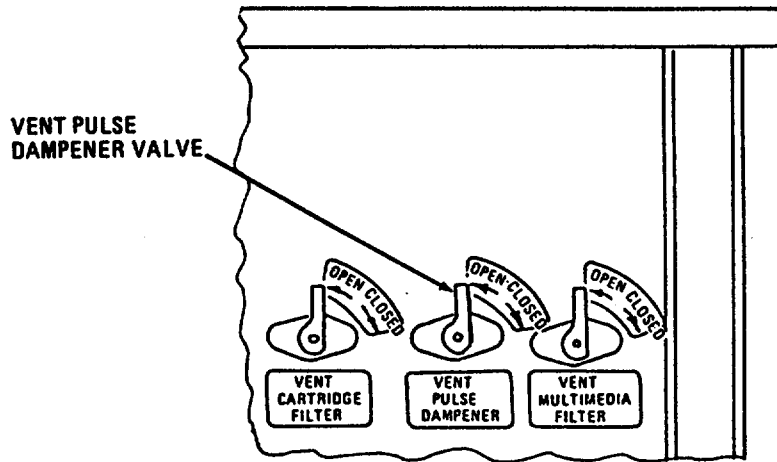
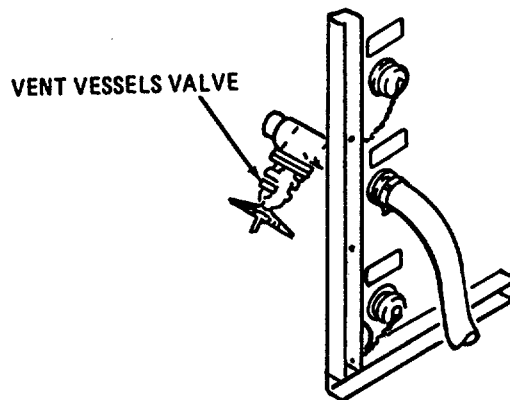

FIGURE 2-59. PULSE DAMPENER VENT VALVE

(8) Observe end of VENT VESSELS hose for water flow and clarity. Note that the water coming out of VENT VESSELS water hose is getting clearer and clearer. Within 10 minutes, water should be clear. As soon as water appears completely clear, proceed to step i.



WARNING

Vent vessels water flow is not potable. Run water downstream from raw water source as far away as possible

NOTE

The filtered water is bypassing the R. O. vessels. MC and AF units are skid mounted

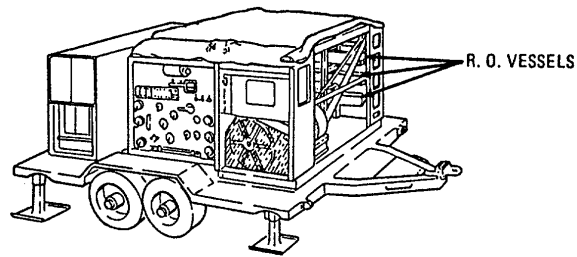

FIGURE 2-60. R. O. VESSELS

i. Examine Filtered Water for Clarity.

(1) From Storage Box No. 3, get the plastic graduated cylinder (called turbidity tube) used for checking clarity of water

(2) Bottom of turbidity tube has a white bullseye set in a black background disc

(3) Go to left front side of ROWPU and observe the seven drain valves

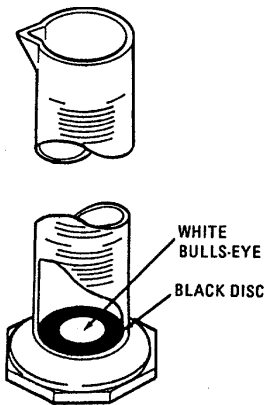

FIGURE 2-61. TURBIDITY TUBE

(4) Draw a sample of 600 milliliters of water from DRAIN NO. 1 CARTRIDGE FILTER into the turbidity tube.

(5) Look down into turbidity tube and you should be able to see both the white bullseye and black disc at the bottom of the tube clearly. If they can be seen clearly, proceed to step j.

(6) If both cannot be seen clearly, run the ROWPU another 10 minutes. Repeat steps (4) and (5).

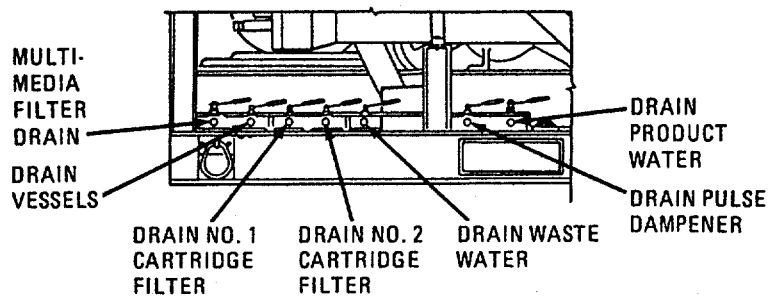

FIGURE 2-62. DRAIN VALVES

5. (7) If after second sampling test, water is not clear, increase POLYMER chemical feed control knob setting by

NOTE

The setting of 60 or 20 ml/min set earlier was only to prevent overdosing of polymer. This rate may be adjusted during operation to improve clarity

- (8) Run ROWPU for 5 minutes, and repeat steps (4) and (5). If both bullseye and black disc can be seen clearly, proceed to step j; if not, proceed to step (9).

- (9) Increase control knob setting by 5.

- (10) Repeat steps (8) and (9) until water is clear.

NOTE

Unless source water is noticeably turbid, it should not be necessary to increase POLYMER setting beyond 50.

j. Final Adjustments.

- (1) Set SODIUM HEX valve to RUN position (figure 2-10).

(2) Check that the vent product water valve (figure 2-6) is in the OPEN position. The vent product water valve allows air to escape from the product water line and lowers product water pressure. It should be closed once product water has been produced.

- (3) Check that the REGULATE PRODUCT flow valve (3, figure 2-64) is fully open.

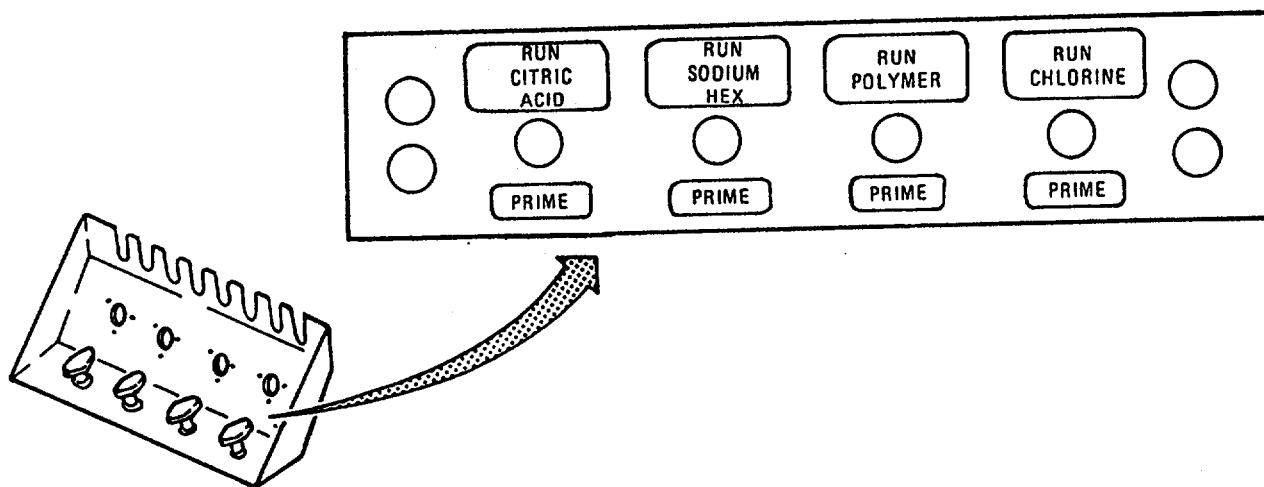

FIGURE 2-63. NAME PLATES

NOTE

You are now ready for full operation under normal circumstances. A few more adjustments are required while you produce water and store it in tanks for future use.

(4) Slowly close VENT VESSELS valve (figure 2-5) located behind VENT VESSELS Outlet (1). This allows filtered water to enter R.O. vessels.

CAUTION

To prevent damage to the R. O. elements, closely observe R. O. PRESSURE PSI gauge when adjusting REGULATE PRODUCT FLOW valve R. O. pressure will increase very rapidly

(5) Slowly adjust REGULATE PRODUCT FLOW valve (3) to the right (clockwise). Watch for an increase in PRODUCT WATER FLOW gauge (2), a decreased flow in BRINE FLOW gauge (4), and increased pressure in the R. O. PRESSURE PSI gauge (5)

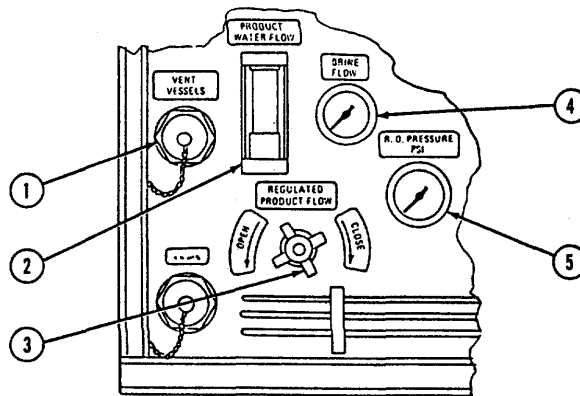

FIGURE 2-64. R. O. PRESSURE AND PRODUCT WATER FLOW GAUGES.

CAUTION

PRODUCT WATER FLOW should not exceed 12 gpm for seawater conditions, 16 gpm for fresh or brackish water. R. O. PRESSURE PSI gauge should not exceed 960 psi (seawater), 500 psi (fresh or brackish water). If gauge readings exceed these limits, refer to Section II, Chapter 3, Troubleshooting.

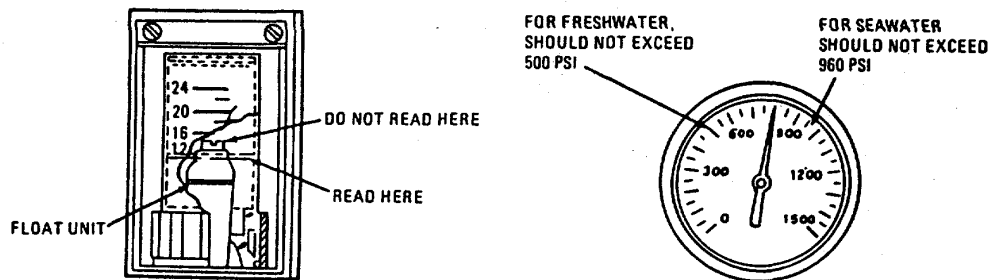

FIGURE 2-65. PRODUCT WATER FLOW GAUGES AND PRESSURE.

(6) Close REGULATE PRODUCT FLOW valve very slowly. Watch gauges until you obtain proper balance shown in table 2-4.

(7) Set CHLORINE valve to RUN position (figure 2-10).

(8) The ROWPU is now in full operation. Check the TDS of the product water (paragraph 2-15c), record the findings in operator's log. If reading is above 1500 ppm, refer to Section II, Chapter 3, Troubleshooting. Keep watching your gauges and lamps. Complete the operator's record (log) hourly. Refer to table 2-4 for normal and trouble point indications.

Table 2-4. Gauge Readings, Normal and Trouble-point

Gauge/Indicator	Normal Reading	Trouble point reading
CARTRIDGE FILTER	0 to 20 psid	Over 20 psid
MULTIMEDIA FILTER	10 psid or less, not exceed 5 psid of log reading at startup	Either over 10 psid or not within 5 psid of log reading at startup
RAW WATER FLOW	27 to 33 gpm	Drop to 25 gpm or less
BRINE FLOW	16 to 24 gpm	Below 15 gpm
PRODUCT WATER FLOW:		
SALT WATER	6 to 12 gpm	Below 6 and above 12 gpm
FRESH WATER	Up to 16 gpm	Above 16 gpm
BRACKISH WATER	Up to 16 gpm	Above 16 gpm
R.O. PRESSURE PSI:		
SALT WATER	Not to exceed 960 psig	Above 960 psig
FRESH WATER	Not to exceed 500 psig	Above 500 psig
R.O. VESSELS	50 to 100 psid	Above 100 psid
TDS OF PRODUCT WATER	Below 1500 ppm	1500 ppm or above

(9) Periodically check the brine tank.

(a) Covered?

(b) Full? Up to 3 inches from top?

(c) When brine tank is full, remove the canvas brine hose coming from the ROWPU and allow to drain on the ground.

WARNING

Ensure that the drained brine water runs towards lower ground as far from the raw water source as possible

(d) Let brine flow on the ground until after next backwash, then put the hose back into tank.

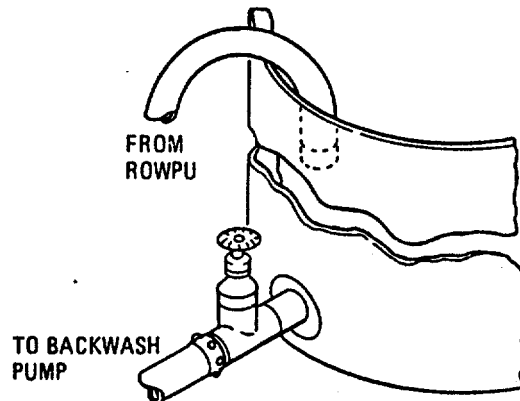

FIGURE 2-66. BRINE WATER SHUTOFF VALVE

NOTE

The R. O. VESSELS gage is a good indicator of the condition of the R. O. elements. Gage should indicate 50 to 100 psid while R. O. elements are in good condition

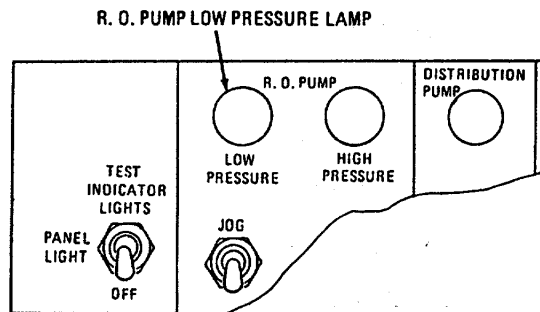

FIGURE 2-67. R.O. PUMP LOW PRESSURE LAMP

(10) Check R. O. PUMP LOW PRESSURE lamp in the upper left corner of control box assembly. It must be off while ROWPU is operating normally. If the lamp comes on, refer to table 3-2 for troubleshooting procedures

(11) Check R. O. PUMP HIGHI PRESSURE lamp in upper left of control box assembly. It must be off at all times while ROWPU is operating normally. If that lamp ever comes on, the R. O. pump will shut down at once. (Other pumps will continue to run). Check table 3-2, for troubleshooting procedures

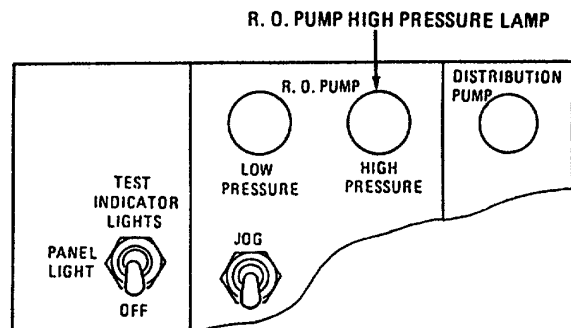

FIGURE 2-68. R. O. PUMP HIGH PRESSURE LAMP

(12) Watch water level in product water tanks.

(a) Keep tanks covered.

(b) To distribute water, start distribution pump.

(13) To start distribution pump, proceed as follows:

(a) Set DISTRIBUTION PUMP switch on control box assembly panel to START.

(b) Lamp comes on.

(c) Run distribution pump until user has enough water, then switch to STOP.

(d) If product water tank is full, stop ROWPU until more water is needed. (See paragraph 2-14 for normal shutdown procedure.)

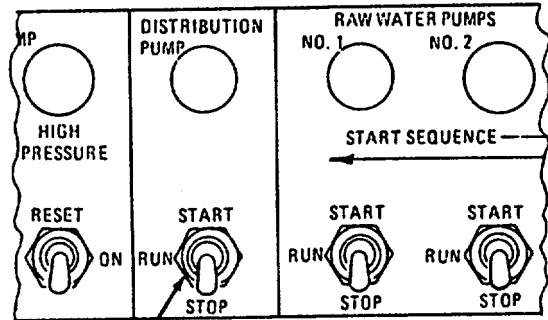

DISTRIBUTION PUMP SWITCH
 FIGURE 2-69. DISTRIBUTION PUMP SWITCH

2-10. BACKWASH OF MULTIMEDIA FILTER.

NOTE

The multimedia filter should be backwashed:

- After 20 hours of ROWP'U operation, or
- Multimedia filter gage reading is over 10 psid, or
- Multimedia filter gage reading exceeds 5 psid of log reading at startup, or
- ROWPU is to be shut down.

a. General. The backwash cycle is an up-flow operation. Water flows from the bottom to the top of the tank and then out to drain through the backwash flow control, washing out turbidity and settling the filter bed. The filter has five separate backwash stages. The first stage of backwash is at approximately 70 gpm to fluidize the bed. A second backwash stage begins at approximately 120 gpm, tumbles at the bed, and scours the particles against one another when the backwash diaphragm valve opens. The backwash diaphragm valve then closes, returning the backwash rate to approximately 70 gpm to restratify the media bed. The rinse cycle is a down flow operation. Water flows from the top of the tank through the filter bed and out to drain. This displaces the backwash water in the tank, and preconditions the filter bed before the filter reaches the purge cycle. The purge cycle is rapid downflow rinse to remove turbidity from the bottom of the filter and recondition the filter bed prior to the return to service

b. Backwash Timer and Multimedia Filter Control Valve (figure 2-14).

The direction and rate of water flow through the multimedia filter are controlled by the control valve and backwash diaphragm valve. The control valve consists of six diaphragms which open and close during the timer cycles of backwash, conditioned rinse, and service (service means normal ROWPU operation). As the backwash timer automatically changes cycles, its pilot valve changes position. When the backwash timer pilot valve changes position, it hydraulically closes and opens the diaphragms in the control valve. During the 120 gpm portion of the backwash cycle (referred to as "fast backwash") the backwash timer solenoid valve sends water to the backwash diaphragm valve (located just under the control valve). This opens the backwash diaphragm valve, resulting in the higher rate of backwash water flow.

The solid state timer is approximately 8 inches high, 10 inches wide and 6 inches deep. Protruding from the bottom of the timer is the pilot controller. Inside the timer is a white OVER-CURRENT PROTECTION PUSH TO RESET switch and six green LED (light emitting diode) indicator lights. The solid state timer operates automatically and does not contain any operator controls. The six green indicator lights illuminate in response to the following backwash functions:

Indicator Light:

REGEN - Flashing light indicates backwash timer is in operation.

0 - IN SERVICE (Backwash cycle not in operation)

1 - SLOW BACKWASH

2 - FAST BACKWASH

3 - SLOW BACKWASH II

4- RINSE

CAUTION

To prevent damage to the equipment, the OVER-CURRENT PROTECTION PUSH TO RESET switch must not be depressed during operation. RESET switch should only be depressed when required by troubleshooting or maintenance procedures.

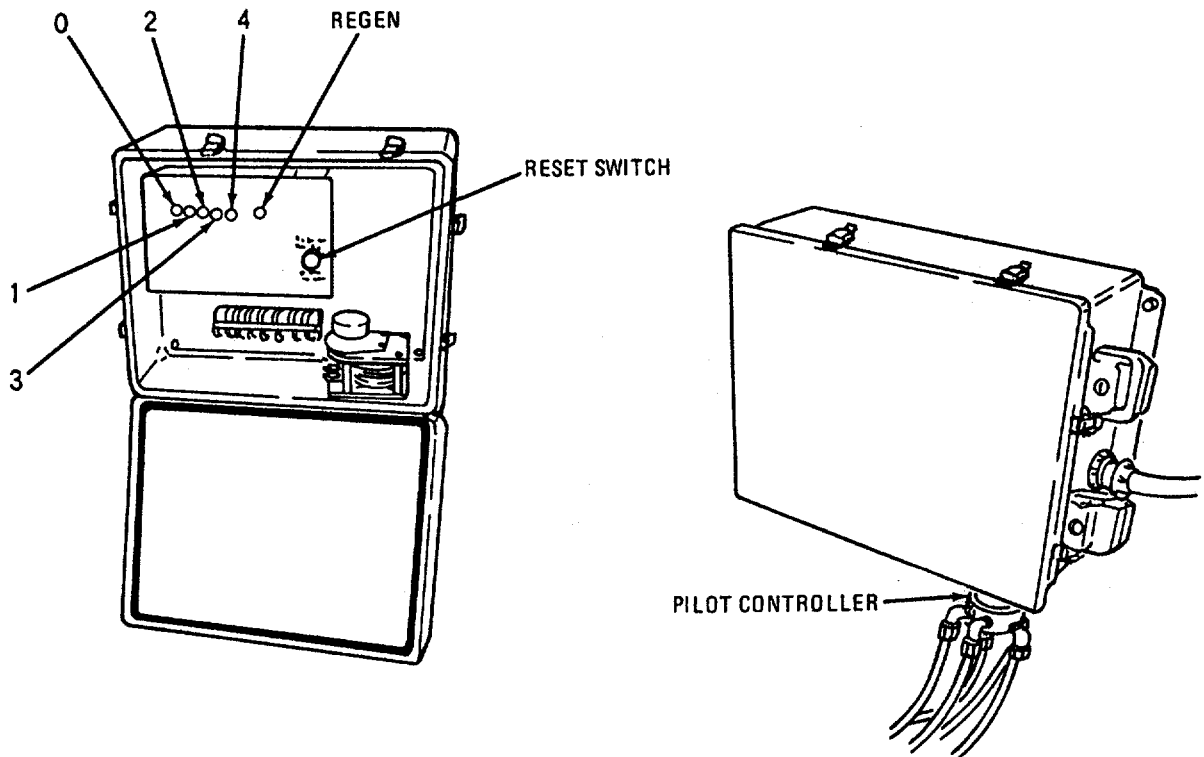

FIGURE 2-70. SOLID STATE TIMER

c. Normal Backwash.

- (1) Shut the ROWPU down in the normal way (paragraph 2-14).
- (2) Make sure R.O. ELEMENT CLEANING switch (figure 2-4) on side of control panel is down (off).
- (3) Check water level in brine water tank. Tank should be full.
- (4) Ensure basket strainer in backwash pump is not clogged.
- (5) Open brine water tank valve.
- (6) Loosen vent plug on top of backwash pump to prime pump.
- (7) Turn BACKWASH VALVE handle downward to BACKWASH.

CAUTION

Do not hold START BACKWASH switch up for more than 5 seconds to avoid damage to the controls.

- (8) Push BACKWASH switch up to START position and release immediately.
- (9) When a steady stream of water flows from backwash pump vent plug, tighten vent plug.

NOTE

Solid-state timer will come on immediately. BACKWASH PUMP ON lamp will come on, pump will start and backwash water will flow through the multimedia filter and out the waste water hose. The multimedia filter gauge needle will move fully to right. During backwash, the backwash water flow rate varies automatically from 0 to 70 to 120 gpm while washing and rinsing. Backwash operation is automatic and lasts about 13 minutes

(10) When backwash is complete, BACKWASH PUMP ON lamp will go off and, pressure gauge and backwash flow gauge will return to "O". When backwash pump shuts off, turn BACKWASH valve handle upward to left to NORMAL position. Close valve at brine water supply tank.

CAUTION

Since the multimedia filter uses brine water to backwash, it should not be drained or left inoperative following backwash without first flushing with raw water for 5 minutes. Flush by operating filter normally.

(11) Start up the ROWPU after backwash in the normal manner (paragraph 2-9).

12-11. CITRIC ACID FEED.

After 20 hours of continuous operation, feed citric acid solution into filtered water in order to remove minor amounts of scale which could accumulate during normal operation.

WARNING

Chemicals can cause sickness or even death if extreme care is not taken. Wear protective devices when working with these solutions.

- a. Using citric acid measure, put 0.75 pounds of citric acid in pail previously marked for CITRIC ACID.

- b. Fill CITRIC ACID pail with 3 gallons of brine.
- c. Stir chemical and brine with wooden paddle, and pour solution into 5 gallon chemical container.
- d. While the ROWPU is operating normally, set the citric acid chemical feed pump valve to RUN; chemical feed control knob should already be set to maximum setting (100).
- e. Wait for 10 minutes.
- f. Draw a 250-ml water sample from brine hose at backwash tank and check for a pH reading of 5 to 8 (paragraph 2-15). If that reading is over 8, feed a new batch of citric acid chemical mixture, using 1.5 pounds citric acid mixed with 3 gallons brine
- g. Set CITRIC ACID PUMP valve to PRIME. Feed is completed.

2-12. R.O. ELEMENT CLEANING METHODS.

It will be necessary to clean the R. O. elements to improve total dissolved solids (TDS) rejection, and reduce operating pressure (P. S. I.). Two methods of cleaning elements are available. One method, used to remove mineral deposits such as iron and calcium carbonate, is to feed citric acid solution through the vessels (paragraph 2-13a) The second method is to circulate Triton X-100 soapy cleaning solution through the vessels (paragraph 2-13b) Triton X- 100 is more effective for removing dirt and silt. The R.O. elements must be cleaned:

- a. Whenever the pressure shown on R.O. PRESSURE P.S.I. indicator rises to above 960 for seawater or 500 for fresh water.
- b. Product water output drops several gallons per minute on PRODUCT WATER FLOW indicator, with no change in raw water temperature.
- c. BRINE FLOW increases noticeably, and adjustment of REGULATE PRODUCT FLOW valve does not correct the BRINE FLOW indication.
- d. When R.O. vessels differential pressure increases by 20% over initial reading.

2-13. R.O. ELEMENT CLEANING PROCEDURE.

- a. Citric Acid Method

CAUTION

R.O. ELEMENT CLEANING switch (figure 2-4) must be in OFF position except while cleaning R.O. elements.

- (1) First backwash multimedia filter (see paragraph 2-10).

WARNING

Be sure that the drained brine water runs toward lower ground as far downstream from the raw water source as possible.

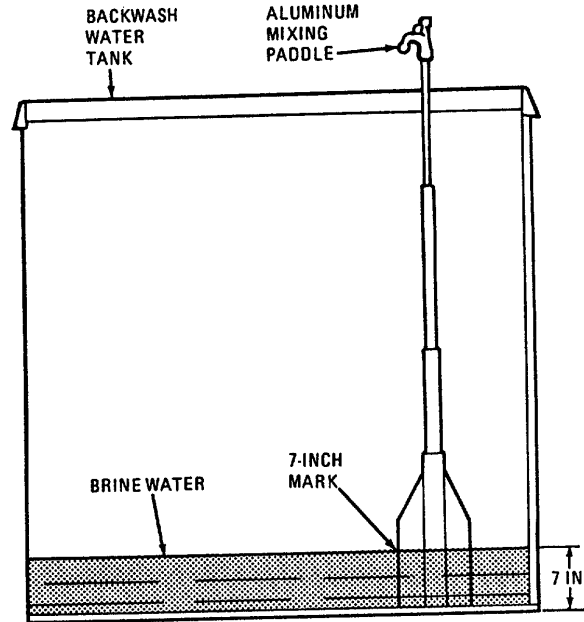

FIGURE 2-71. BACKWASH WATER TANK

(2) After backwashing, adjust brine water level in tank to 7 inches. You may have to drain water from tank or operate ROWPU normally until you obtain 7 inches.

(3) Check for 7-inch brine water level with telescoping aluminum mixing paddle. Paddle has a 7-inch mark for checking the brine depth.

(4) Begin by adding one pound of citric acid to water in backwash water tank and mix with aluminum paddle until all granules are dissolved. (More citric acid may be added later to bring pH of brine near but not below 3.5

NOTE

If in past, when using same source water, brine has been very alkaline, then more citric acid may be added to start; however, never let pH of brine drop below 3.5 or damage to the R.O. elements will occur.

(5) Remove backwash hose from outlet of the backwash pump and connect VENT VESSELS hose to outlet of backwash pump.

(6) Make sure REGULATE PRODUCT FLOW valve is open (counterclockwise).

(7) Open VENT VESSELS valve. This valve should remain open at all times except when producing purified water.

(8) Check to see that the valve on the bottom of backwash water tank is fully open (turned fully to the left (counterclockwise) until it stops).

(9) Remove product water hose (14, figure 2-27) from product water tank and allow hose from ROWPU to drain on the ground. Leave brine water hose in backwash water tank.

(10) Start element cleaning. Push ELEMENT CLEANING switch (figure 2-4) up to START position. Release switch. Switch automatically goes to RUN position. Element Cleaning starts.

NOTE

If element cleaning does not start, it may be necessary to loosen vent plug on backwash pump to purge air. Tighten vent plug when pump is primed.

(11) Within a few seconds, BRINE FLOW indicator (17, figure 2-4) should show a flow of 16 gpm or more.

CAUTION

If pH of water circulating through R. O. elements drops below 3.5, element membranes may be damaged.

(12) After five minutes, check pH (paragraph 2-15) of water discharging back into brine tank; it should be near, but not below, 3.5. If it isn't, add another pound of citric acid and stir until all granules are dissolved.

NOTE

If in past, when using the same source water, brine has been very alkaline, then more citric acid may be added at a time; however, in no case should the pH of the water circulation through R.O. elements drop below 3.5.

(13) Continue checking pH and adding lib of citric acid at 5 minute intervals until pH of water is near, but not below, 3.5.

(14) Allow citric acid solution to circulate for 45 minutes. Periodically check the temperature of the water discharging back into brine tank; use thermometer in Storage Box No. 2.

CAUTION

Temperature of solution will rise during element cleaning. At no time should it exceed 120 degrees. If temperature rises above 120 degrees, stop recirculating citric acid solution, and resume normal operation.

(15) Stop recirculation by pushing the ELEMENT CLEANING SWITCH down to OFF.

(16) Remove VENT VESSELS hose from outlet of the backwash pump and connect backwash water hose to backwash pump outlet.

WARNING

Drainage lagoon should be located down stream from unit.

(17) Drain citric acid solution into a shallow man-made lagoon a reasonable distance away from the unit. Close valve at discharge of brine water tank (figure 2-66).

(18) Perform startup procedures for normal filtering operation (paragraph 2-9).

(19) Allow the ROWPU to operate for 10 minutes with the brine and product water hoses out of tanks and with REGULATE PRODUCT FLOW valve fully open (turned fully to the left until it stops) to rinse the R.O. pressure vessels.

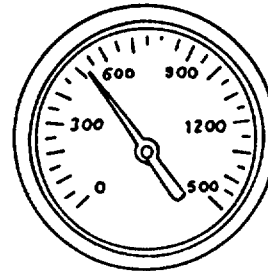
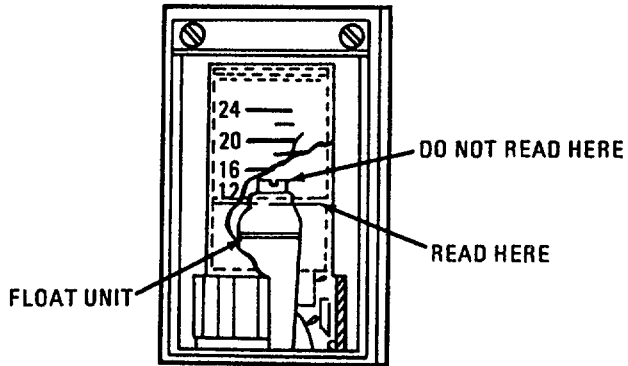

FIGURE 2-72. PRODUCT WATER FLOW INDICATOR

FIGURE 2-73. R. O. PRESSURE GAGE

(20) Adjust REGULATE PRODUCT FLOW valve until PRODUCT WATER FLOW gage reads under 16 gpm (fresh/brackish water) or 12 (seawater), and R.O. PRESSURE PSI reads under 500 (fresh/brackish water) or 960 (seawater).

(21) Allow ROWPU to run 3 minutes, and check product water TDS (paragraph 2-15c).

NOTE

Some elements require 24-72 hours of operation before TDS decreases to acceptable standards. If TDS is still over 1500 ppm after cleaning, allowing ROWPU to run longer may lower TDS.

(22) Only after obtaining TDS level under 1500 ppm, place product water hose back into product water tank, above water level.

b. Triton X Detergent Method. Follow same procedures for CITRIC ACID METHOD (paragraph 2-13a), with following exceptions:

(1) In step (4), instead of citric acid use 2160 ml (3000 gallon tank) of overpacked SURFACTANT (Triton X detergent).

(2) In step (17), continue to rinse elements until you can no longer see suds in rinse water.

12-14. SHUTDOWN PROCEDURES.

For normal shutdown, set valves and switches as shown in table 2-5 and figure 2-74.

NOTE

Index numbers follow order of table 2-5. For order numbers 1, 2, 4, 5 refer to figures 2-10, 2-7, 2-6 and 2-5, respectively.

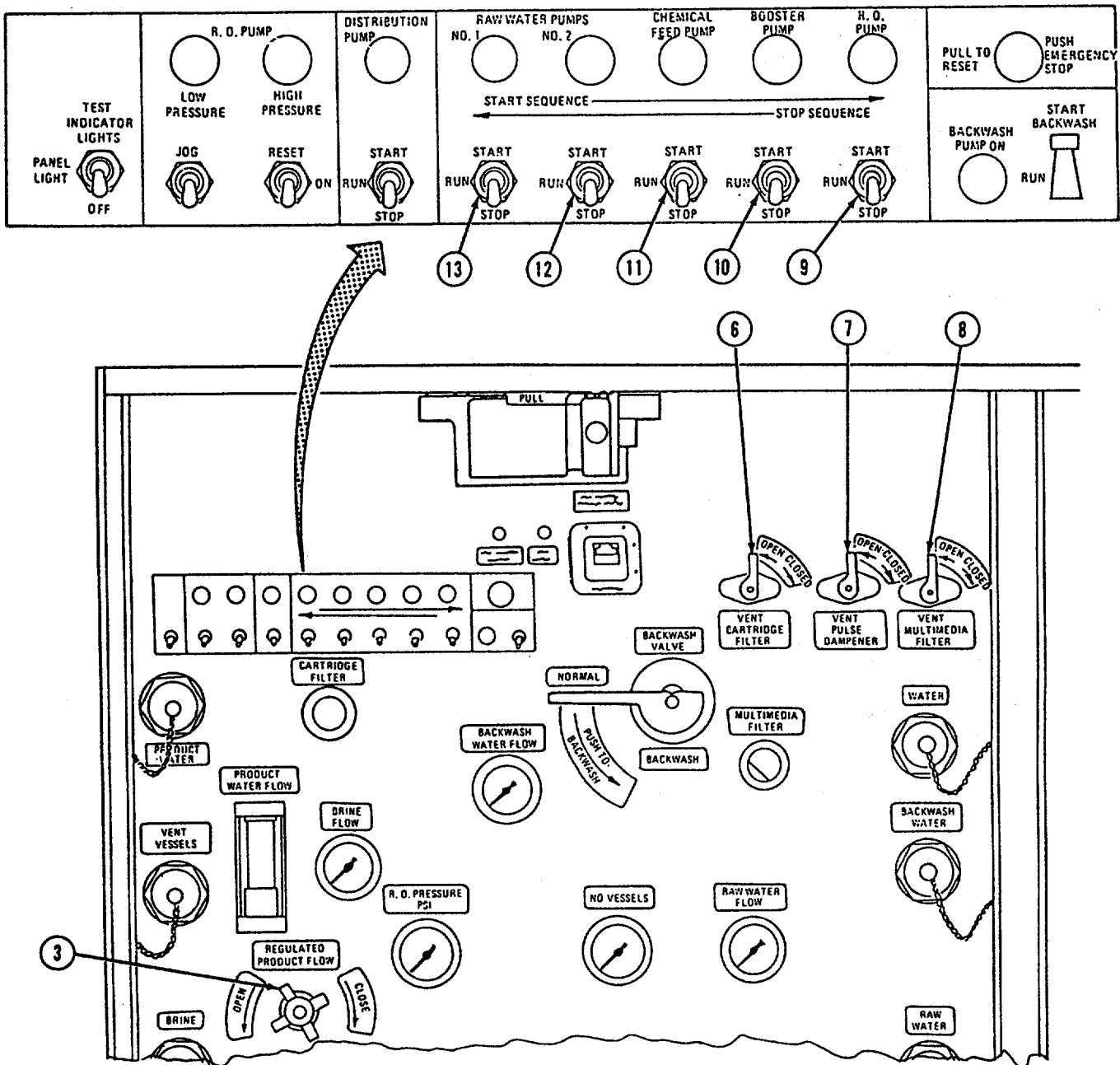

FIGURE 2-74. SHUTDOWN POSITION OF CONTROL PANEL SWITCHES AND VALVES

CAUTION

Follow the exact order of shutdown steps in table 2-5 to prevent damage to the ROWPU.

Table 2-5. Shutdown Position of Valve or Switch

Order	Valve or Switch	Position
1	CHEMICAL FEED PUMP valves (figure 2-10)	Prime
2	CHEMICAL FEED CONTROL knobs (figure 2-7)	Fully counterclockwise
3	REGULATE PRODUCT FLOW valve	OPEN
4	VENT PRODUCT WATER valve (figure 2-6)	OPEN
	CAUTION After opening the REGULATE PRODUCT FLOW valve fully, wait 5 minutes before opening vent vessels valve.	
5	VENT VESSELS valve (figure 2-5)	OPEN
6	VENT CARTRIDGE FILTER valve	OPEN
7	VENT PULSE DAMPENER valve	OPEN
8	VENT MULTIMEDIA FILTER valve	OPEN
9	R.O. PUMP switch	STOP
10	BOOSTER PUMP switch	STOP
11	CHEMICAL FEED PUMP switch	STOP
12	RAW WATER PUMP NO. 2 switch	STOP
13	RAW WATER PUMP NO. 1 switch	STOP
	NOTE CB-2, CB-8 AND CB-9 must remain on (up) to perform backwash procedures.	
14	CIRCUIT BREAKERS CB-1 THRU CB-9	OFF(DOWN)

2-15. OPERATION OF AUXILIARY EQUIPMENT.

WARNINGS

- Generator sets must not be operated in enclosed area unless exhaust discharge is properly vented to the outside. Be alert at all times during operation for odors and exposure symptoms to carbon monoxide.
- Operating noise level of the generator set can cause hearing damage. Ear protectors, as recommended by medical/safety personnel, must be worn when working near set.

a Generator Set (ARMY). Instructions for operating the generator are contained in the applicable generator set manual (TM 5-6115-465-12 for NSN 6115-00-118-1240).

b Color Comparator Test Kit. Instructions to determine the pH values and chlorine residual in water are contained in the color comparator test kit (paragraph 2-2n, figure 2-13). The Diethyl-P-Phenylene diamine (DPD) tablets are not part of the test kit, but are included in Storage Box No. 3.

c TDS Meter. The TDS (total dissolved solids) meter is a calibrated meter that measures how much electric current can flow through a sample of water. Pure water passes almost no current.

- (1) Description of the TDS meter:
- (a) Reads in ppm (parts per million) or in mg/l (milligrams per liter).
 - (b) Has three scales: 0 to 5x10, 0 to 5x100, and 0 to 5x1000.
 - (c) Change scales with the range switch.

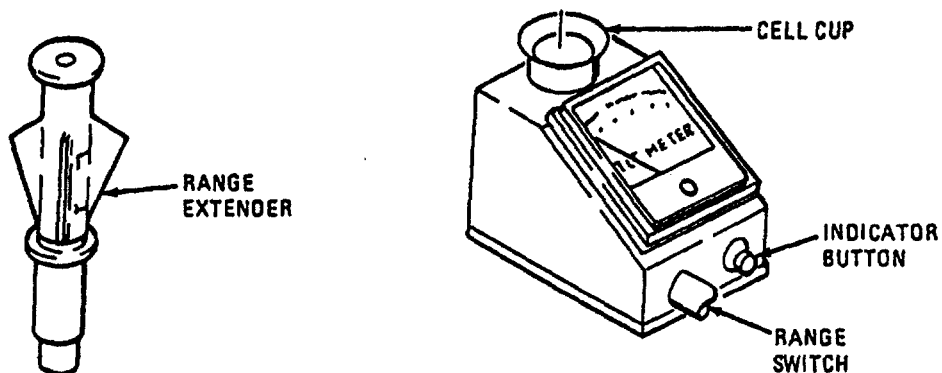

FIGURE 2-75. TOTAL DISSOLVED SOLIDS (TDS) METER

CAUTION

Always start with meter set on the 0 to 5x1000 scale. If you use a lower scale first, you may damage the meter.

NOTE

The TDS meter is factory calibrated and suitable for use when treating fresh (lake, stream, pond, river) water. When treating seawater and brackish water, it is necessary to recalibrate the meter. If your meter has both "442 and "NaCl" internal standards stamped on the bottom plate, obtain a standard sodium chloride (NaCl) solution (ARMY-SC-4610-97-CL-E16; MC-SL-3-08580C) and refer to subparagraph (3).

(2) Recalibration instructions for meters with both internal standards (442 and NaCl) stamped on the bottom of the meter.

- (a) Set range switch to "S" (internal standard).
- (b) Remove bottom plate to gain access to master calibration control.
- (c) Press indicator button and hold in it.
- (d) Adjust the master calibration control with your finger until meter reads same as the value stamped on the bottom plate for the water you will be treating (442 for fresh water and NaCl for seawater.).
- (e) Release indicator button.
- (f) Replace bottom plate.

(3) Recalibration instructions for meters with only "442" internal standard stamped on bottom plate: (a) Obtain a standard sodium chloride (NaCl) solution and note the ppm (parts per million) value printed on bottle.

- (a) Remove snap-in disc on bottom cover of TDS meter to gain access to the master calibration control.
- (b) Rinse cell cup three times with the standard sodium chloride (NaCl) solution, then fill again.
- (c) Set range switch to the 1000 scale.
- (d) Press indicator button and hold it in.
- (e) Adjust the master calibration control until the meter reads the value on solution bottle, then release indicator button. Remember to multiply meter reading by 1000.
- (f) Set range switch to "S" (internal standard).
- (g) Press indicator button, and hold it in.
- (h) Note the dial reading and write it down for future reference, then release indicator button. This value is the internal standard for a sodium chloride (NaCl) solution.
- (i) Replace snap-in disc in bottom cover.

(4) Calibration Check: (a) Set range switch to "S" (an internal standard).

- (b) Press indicator button. Read the 0 to 5 scale to the nearest tenth.
- (c) For fresh water, meter is ready for use if it matches the 442 ppm internal standard marked on bottom plate. For seawater or brackish water, meter is ready if its reading matches the "NaCl" internal standard, which, if not stamped on bottom plate, was noted in step (3)(i).
- (d) If reading is not the same, notify organizational maintenance to replace TDS meter.

CAUTION

To avoid shorting TDS meter, keep the meter dry. Do not spill water or any other liquid on the meter. Do not damage meter by removing or twisting cell cup.

NOTE

Be sure cell cup is clean; if required, wash with soap and the purest water available.

(5) Testing.

- (a) Rinse cell cup three times with water to be tested.
- (b) Fill cell cup to half-inch from top with water to be tested.

NOTE

Do not use range extender when testing product water.

- (c) Push range extender into cup, seating the O-ring.

CAUTION

Always start with meter set on the 0 to 5 x 1000 scale. If a lower scale is used first, the meter may be damaged.

- (d) Set range switch to 0 to 5 x 1000 scale.

(e) Press indicator button. If reading is less than 500 switch to the 6 to 5x100 scale range. If reading is below 50 switch to 0 to 5 x 10 scale range.

(f) Record highest 0-to-5 reading by range factor used to get that reading (10, 100, or 1000) to get proper value inppm.

NOTE

If using the range extender, multiply this value by 10.

(g) Remove range extender and thoroughly rinse extender and cell cup three times using purest water available. Wipe dry with clean cloth.

12-16. PREPARATION FOR MOVEMENT

- a Backwash ROWPU filters (paragraph 2-10) and clean R.O. elements (paragraph 2-13).
- b Shut off ROWPU normally (paragraph 2-14).
- c Remove strainer and hose from water source.
- d Drain ROWPU pipes, filters, and connections
 - (1) Open seven drain valves (paragraph 2-2i)
 - (2) Open five vent valves (paragraph 2-7b).

e Drain R.O. pump as described below:

CAUTION

To prevent damage to R.O. pump, do not operate R.O. PUMP JOG switch (43, figure 2-4) more than 5 seconds at a time.

NOTE

The JOG switch can be used when the R.O. Pump LOW PRESSURE lamp is on.

(1) After water stops flowing out of drains, push R.O. PUMP JOG (43, figure 2-4) to JOG. Hold it there for 3 to 5 seconds to force water from pump.

(2) Repeat operation of R.O. pump with JOG switch until no more water comes from the DRAIN PULSE DAMPENER drain (figure 2-38). After jogging the R.O. pump, some dripping from the drain is allowable.

(3) Open front and rear sample valves all of the way to allow R.O. vessels to drain. Close when fully drained.

(4) Tag and disconnect the eight (8) control lines on the multimedia filter control valve (figure 2-14) and backwash timer pilot valve, and allow lines to drain. After draining the lines reconnect them to the valves as tagged.

f. Drain booster pump:

(1) Run BOOSTER PUMP (figure 2-55) for no more than 5 seconds.

(2) Set switch to STOP.

(3) Repeat the last two steps until no more water comes from cartridge filter drains (figure 2-9).

g Drain chemical feed pumps as described below:

WARNING

Chemicals used for operating ROWPU can kill you. The chemicals alone or in mixture can be dangerous. Always wear protective clothing and make sure area is well ventilated.

(1) Empty and rinse all chemical utility containers and fill them with brine water.

(2) Set chemical pump valves to PRIME (figure 2-63).

(3) Run pump motor (38, figure 2-4) to rinse chemical pumps. Ensure all control knobs (figure 2-7) are set to their maximum settings.

(4) Disconnect intake hoses from all chemical containers.

(5) Allow pump to run for 5 to 10 seconds to empty water from chemical pumps.

(6) Stop pump motor and empty chemical containers.

(7) Set chemical valves to PRIME position.

(8) Drain all hoses.

(9) Ensure chemical containers are secure in rack and rack is secured inside ROWPU frame or on trailer.

h. Drain Product Water Tanks and Pump:

(1) Start and run distribution pump (41, figure 2-4) until all water is drained from both product water tanks.

(2) Shut off distribution pump. Set DISTRIBUTION PUMP circuit breaker CB-5 to off (down). Disconnect power cord from DISTRIBUTION PUMP connector (J-5).

(3) Roll up electrical cord onto pump frame.

(4) Disconnect and roll up water hoses.

i. Drain Brine Water Tank and Backwash Pump:

CAUTION

Use the ELEMENT CLEANING SWITCH (24, figure 2-4) to start the backwash pump. Using the START BACKWASH SWITCH will cause the unit to go into the automatic backwash cycle.

(1) Disconnect backwash water hose from control panel. Secure hose away from unit.

(2) Start and run backwash pump using ELEMENT CLEANING SWITCH, until all water is drained from brine water tank. Turn off backwash pump.

(3) Close backwash water (brine water) and tank shut-off valve (figure 2-66).

(4) Disconnect backwash suction hose at backwash pump.

(5) Open draincock on bottom of backwash pump. Drain pump and backwash strainer.

(6) Disconnect backwash discharge hose from backwash strainer.

(7) Cap and disconnect strainer. Strap backwash strainer to frame of the pump.

(8) Close draincock on bottom of backwash pump.

(9) Set BACKWASH circuit breaker CB-2 to off (down). Disconnect electrical cord from BACKWASH PUMP connector J-2. Roll cord onto pump frame.

j. Drain Raw Water Pumps No. 1 and 2:

(1) Set RAW WATER PUMP NO. 1 CB3 and RAW WATER PUMP NO. 2 CB4 circuit breakers to off (down).

(2) Open vent valves on raw water pumps No.1 and 2.

(3) Open pump drain valve on raw water pumps No. 1 and 2.

(4) Disconnect strainer and float from raw water pump suction hose. Disconnect hoses from raw water pumps no. 1 and 2.

(5) Roll up electrical cords on pumps.

k. Shut OFF Electrical Power.

(1) Ensure all circuit breakers, CB-1 through CB-9, are off (down).

(2) (ARMY) Shut off Generator Unit according to applicable manual for generator.

(3) (MC and AF) Disconnect power cable from junction box connector J-1.

l. Prepare Hoses, Pumps, and Tanks for Movement.

(1) Disconnect all hoses from ROWPU panel and install caps on panel hose connections.

(2) Remove hoses from pumps (all except chemical feed pump) and separate hoses.

(3) Remove all hose adapters and distribution nozzle. Put adapters and nozzle into Storage Box No. 2.

(4) Roll all rubber hoses and connect the ends.

(5) Drain and roll canvas hoses, starting with male end (male end goes on the inside, female end on the outside).

(6) Put caps on all openings of portable pumps.

(7) Remove covers from all water storage tanks. Fold covers.

(8) Take apart all three water storage tanks, remove valve from brine tank, and cover tank openings.

CAUTION

If any water remains in tanks, tip tank and drain water. Dry tanks before folding.

(9) Fold up tanks.

(10) Fold up ground clothes.

(11) Pull out ground rods using slide hammer and store on ROWPU control panel (figure 2-36).

m. Pack Accessories. Refer to loading plan attached to each storage box lid and pack accessories as indicated. Be sure in-line tDS monitor is removed from control panel and stored securely in Storage Box No. 3.

n. Pack Removable Assemblies. Install pumps, storage boxes, pails, hoses, sledge hammer, aluminum paddle and tanks on ROWPU. Refer to paragraph 1-6, (figures 1-3 through 1-14) as a general packing guide.

- o. Install Frame Cross Braces (figure 2-20).
- p. (ARMY) Refer to figure 2-76 and prepare trailer for movement.

CAUTION

In order to release trailer air brake system, towing vehicle must have 90-130 psi of air pressure.

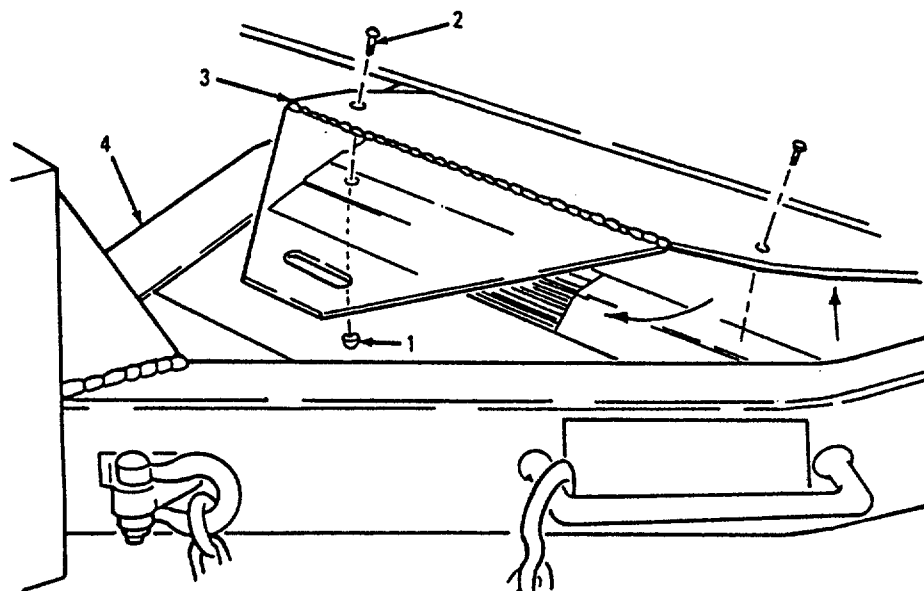

1. REMOVE NUTS (1) AND SCREWS (2) SECURING SAFETY STEP IN PLACE. LIFT STEP UP AND FOLD END PLATE (3) UNDER PLATE (4). LAY BOTH PLATES BACK DOWN AND FASTEN BOTH TO TRAILER DRAWBAR (5) WITH SECURING NUTS (1) AND SCREW (2).

FIGURE 2-76. PREPARATION FOR MOVEMENT (SHEET 1 OF 7) (ARMY)

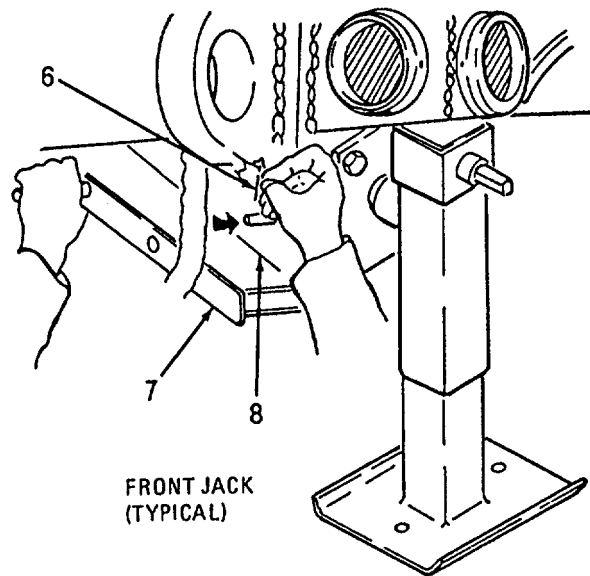

2. REMOVE SAFETY PIN (6) AND CRANK HANDLE (7) FROM REAR OF JACK SUPPORT BRACKET (8).

NOTE

TWO PERSONNEL OPERATING BOTH FRONT LEVELING JACKS ARE REQUIRED TO RAISE THE TRAILER

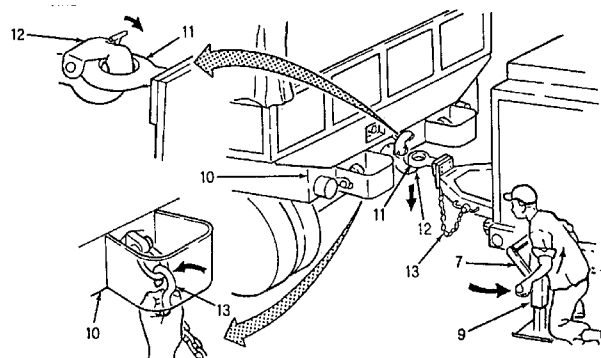

3. PLACE CRANK HANDLE (7) ON FRONT JACK (9). SLOWLY BACK TOWING VEHICLE (10) INTO POSITION SO THAT LUNETTE (11) ALIGNS WITH PINTLE (12). RAISE OR LOWER FRONT OF TRAILER, AS NECESSARY, TO POSITION LUNETTE (11) IN PINTLE (12). CLOSE PINTLE (12) AND SECURE TRAILER SAFETY CHAIN (13) TO TOWING VEHICLE (10).

FIGURE 2-76. PREPARATION FOR MOVEMENT (SHEET 2 OF 7) (ARMY)

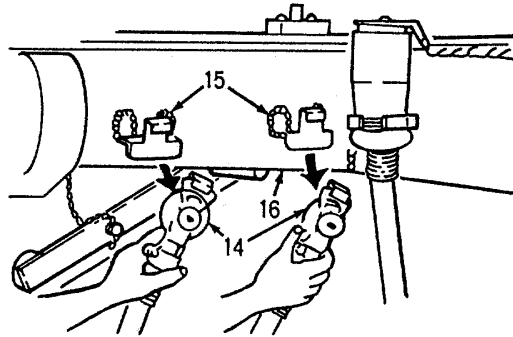

4. REMOVE AIR HOSES (14) FROM DUMMY COUPLING (15) ON TRAILER DRAWBAR (16) AND CONNECT THEM TO TOWING VEHICLE. OPEN AIR BRAKE COUPLING LEVERS ON TOWING VEHICLE.

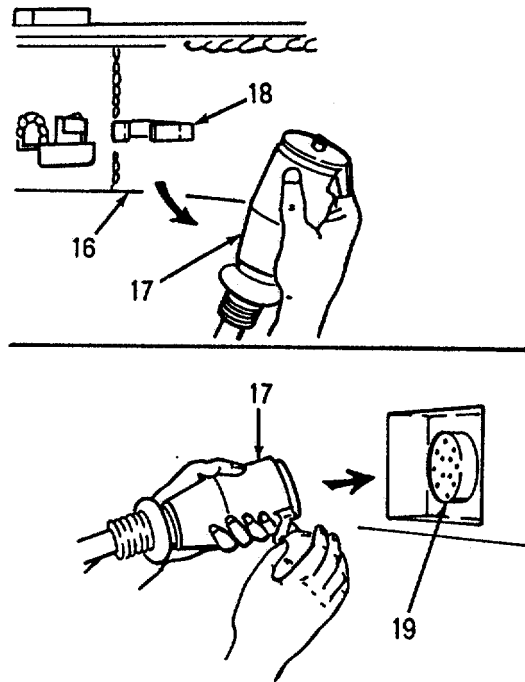

5. REMOVE ELECTRICAL CONNECTOR (17) FROM STOWAGE CLIP (18) ON TRAILER DRAWBAR (16) AND CONNECT IT TO MATING RECEPTACLE (19) ON TOWING VEHICLE.

FIGURE 2- 76. PREPARA TION FOR MOVEMENT (SHEET 3 OF 7) (ARMY)

CAUTION

Movement of trailer without proper positioning of jacks will result in damage or destruction of jacks.

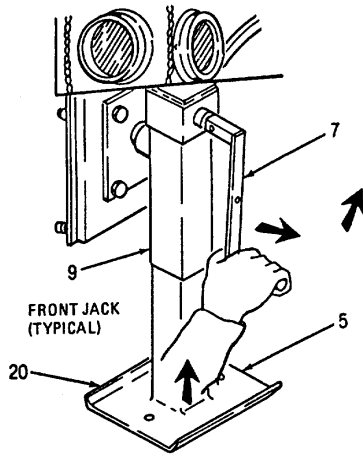

6. WITH CRANK HANDLE (7) IN POSITION ON FRONT JACK (9), TURN CRANK HANDLE COUNTERCLOCKWISE AND FULLY RAISE JACK PAD (20).

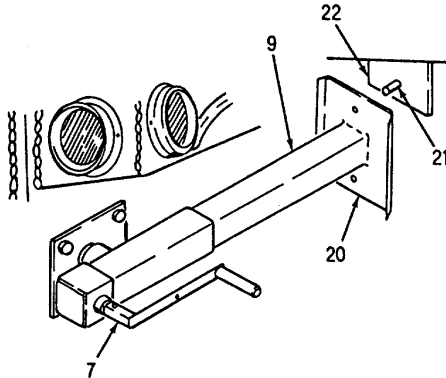

8. POSITION CRANK HANDLE (7) ON FRONT JACK (9) AND TURN HANDLE CLOCKWISE TO EXTEND JACK PAD (20). LINE UP HOLES IN JACK PAD WITH ROUND BAR (21) ON SECUREMENT PLATE (22). EXTEND JACK UNTIL JACK PAD RESTS FIRMLY AGAINST SECUREMENT PLATE.

WARNING

LEVELING JACK IS SPRING LOADED. USE CARE WHEN PULLING OUT LEVELING JACK TO PREVENT PERSONAL INJURY.

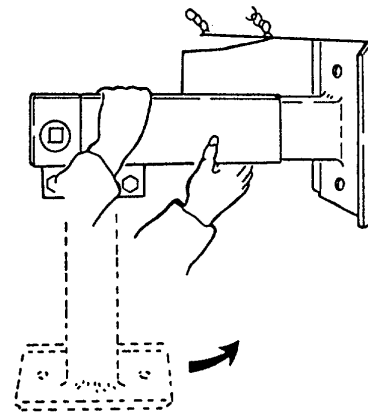

7. TO ROTATE FRONT LEVELING JACK TO HORIZONTAL POSITION, REMOVE CRANK HANDLE. GRASP JACK AND PULL STRAIGHT OUT AGAINST SPRING TENSION. ROTATE JACK UP TO HORIZONTAL POSITION. ALLOW JACK TO SPRING BACK TO LOCKED POSITION.

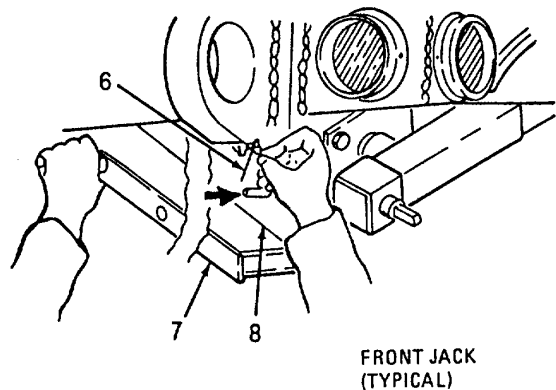

9. REPLACE CRANKHANDLE (7) ON REAR OF JACK SUPPORT RESTS FIRMLY AGAINST SECUREMENT PLATE. BRACKET (8); INSTALL SAFETY PIN (6).

FIGURE 2-76. PREPARATION FOR MOVEMENT (SHEET 4 OF 7) (ARMY)

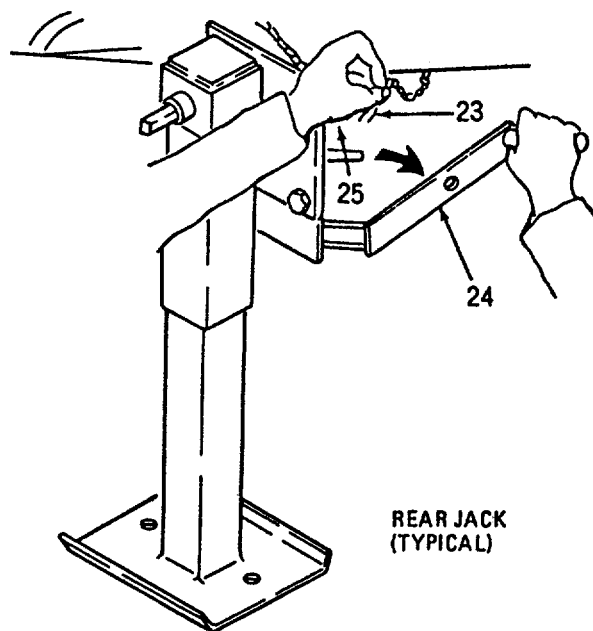

10. REMOVE SAFETY PIN (23) AND CRANK HANDLE (24) FROM REAR OF JACK SUPPORT BRACKET (25).

FIGURE 2-76. PREPARATION FOR MOVEMENT (SHEET 5 Of 7) (ARMY)

WARNING

LEVELING JACK IS SPRING LOADED. USE CARE WHEN PULLING OUT LEVELING JACK TO PREVENT PERSONAL INJURY.

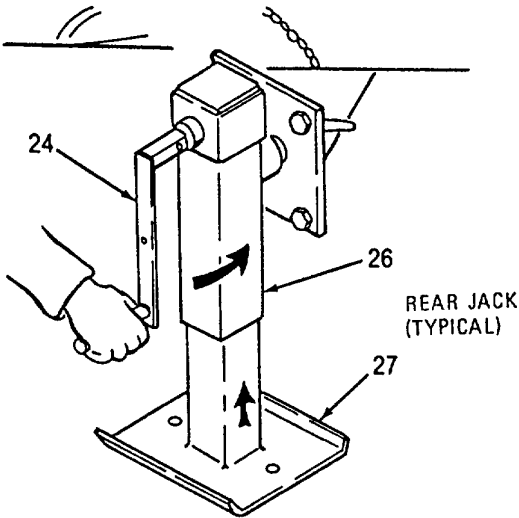

11. POSITION CRANK HANDLE (24) ON REAR JACK (26) AND TURN HANDLE COUNTERCLOCKWISE TO RAISE JACK PAD (27).

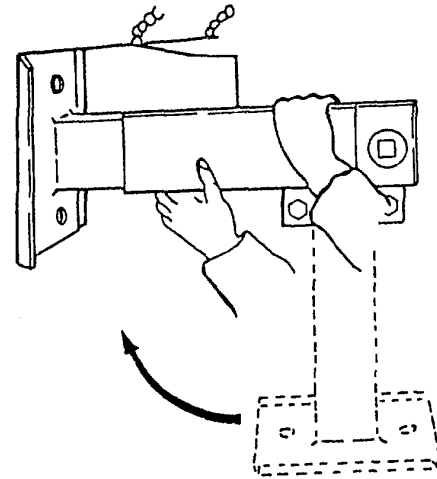

12. TO ROTATE REAR LEVELING JACK TO HORIZONTAL POSITION, REMOVE CRANK HANDLE. GRASP JACK AND PULL STRAIGHT OUT AGAINST SPRING TENSION. ROTATE JACK UP TO HORIZONTAL POSITION. ALLOW JACK TO SPRING BACK TO LOCKED POSITION.

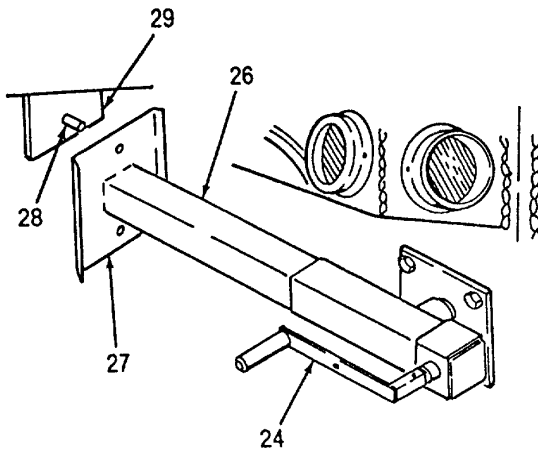

13. POSITION CRANK HANDLE (24) ON REAR JACK (26) AND TURN HANDLE CLOCKWISE TO EXTEND JACK PAD (27). LINE UP HOLE IN JACK PAD WITH ROUND BAR (28) ON SECUREMENT PLATE (29). EXTEND JACK UNTIL JACK PAD RESTS FIRMLY AGAINST SECUREMENT PLATE.

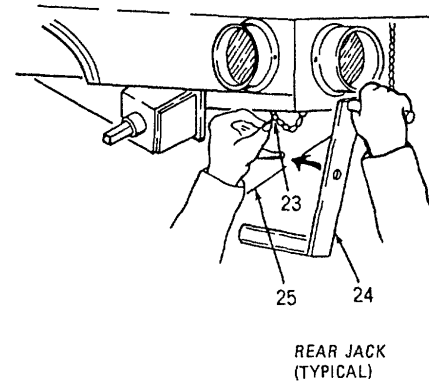

14. REPLACE CRANK HANDLE (24) ON REAR OF JACK SUPPORT BRACKET (25); INSTALL SAFETY PIN (23).

FIGURE 2-76. PREPARATION FOR MOVEMENT (SHEET 6 OF 7) (ARMY)

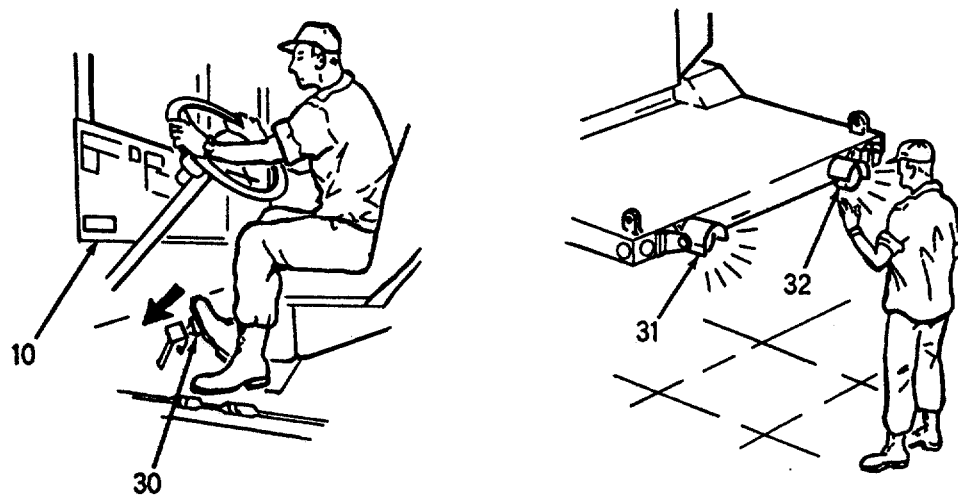

15. DEPRESS BRAKE PEDAL (30) OF TOWING VEHICLE (10); OBSERVE THAT BLACKOUT STOPLIGHT (31) AND TAILLIGHT-STOPLIGHT ASSEMBLIES (32) AS WELL AS BRAKES OPERATE CORRECTLY. IF LIGHTS AND BRAKES OPERATE CORRECTLY, TRAILER IS READY FOR TRANSPORTING.

FIGURE 2-76. PREPARATION FOR MOVEMENT (SHEET 7 OF 7) (ARMY)

Section IV. OPERATION UNDER UNUSUAL CONDITIONS

	Page
Fording	2-91
Emergency Procedures.....	2-91
Water Depth/Water Conditions.....	2-91
Cold Weather.....	2-93
Hot Weather.....	2-95
Dusty and Sandy Areas.....	2-96
Rainy and Damp Areas.....	2-96
Saltwater Areas.....	2-96
Nuclear or Chemical Contaminated Areas.....	2-96

NOTE

Refer to applicable manuals for operation of power generating equipment during unusual conditions.

NOTE

References to trailer are for ARMY ROWPU only.

2-17. FORDING.

No special procedures are required before or during fording. After fording, wash the trailer with fresh water to remove mud and other contaminants as soon as it is convenient to do so. Pay special attention to the electrical connections and brake hoses, the springs, and suspension assembly. Lubricate the entire vehicle in accordance with the instructions in the Lubricating Order, LO 10-4610-240-12/LI08580C-12/TO 40W4-13-31.

2-18. EMERGENCY PROCEDURE.

If the air supply from the towing vehicle and from the trailer air reservoir should be interrupted, the emergency spring brakes will lock. Refer to figure 2-77 as required to reset a locked spring brake.

2-19. WATER DEPTH/WAVE CONDITIONS.

When waves of 2-4 feet at water source exist, or when water depth is too low to prevent sand or debris from entering strainer at water source, it will be necessary to backwash multimedia filter more often.

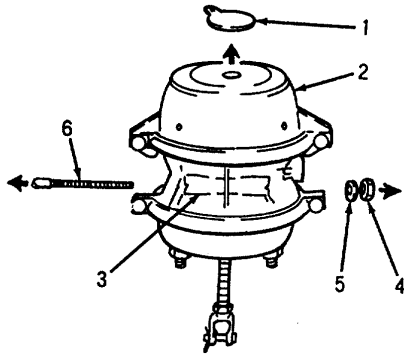

1. REMOVE DUST CAP (1) FROM TOP OF SPRING CHAMBER (2). REMOVE RELEASE STUD ASSEMBLY FROM SIDE SLEEVE (3) BY REMOVING RELEASE STUD NUT (4) AND WASHER (5) FROM RELEASE STUD (6) AND SLIDING RELEASE STUD OUT OF SLEEVE.

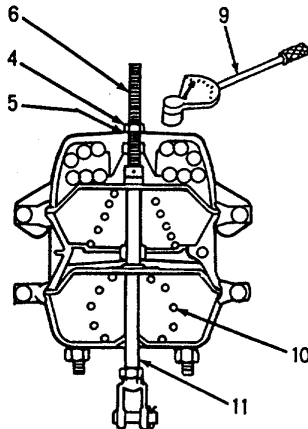

3. PLACE PREVIOUSLY REMOVED RELEASE STUD WASHER (5) AND NUT (4) ON RELEASE STUD (6) AND HAND TIGHTEN THE NUT ONTO RELEASE STUD.

CAUTION

DO NOT APPLY TORQUE GREATER THAN 35 FT-LBS. (6.9M-KG) TO RELEASE STUD ASSEMBLY.

USE TORQUE WRENCH (9) TO TURN RELEASE STUD NUT (4) CLOCKWISE UNTIL COMPRESSION SPRING (10) IS FULLY CAGED. WHILE COMPRESSING SPRING (10), OBSERVE THAT SERVICE PUSH ROD (11) IS RETRACTING AS RELEASE STUD NUT (5) IS BEING TIGHTENED. WHEN COMPRESSION SPRING (10) IS FULLY CAGED, SPRING BRAKE IS MECHANICALLY RELEASED.

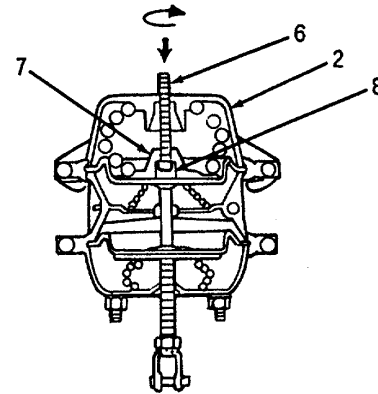

2. INSERT RELEASE STUD (6) THROUGH OPENING (WHEN DUST CAP REMOVED) OF SPRING CHAMBER (2) AND INTO THE PRESSURE PLATE (7). TURN RELEASE STUD (6) 1/2 TURN CLOCKWISE INTO PRESSURE PLATE (7) TO SECURE CROSSPIN (8) IN CROSSPIN AREA OF PRESSURE PLATE (7). THEN LOCK PRESSURE STUD INTO MANUAL RELEASE POSITION.

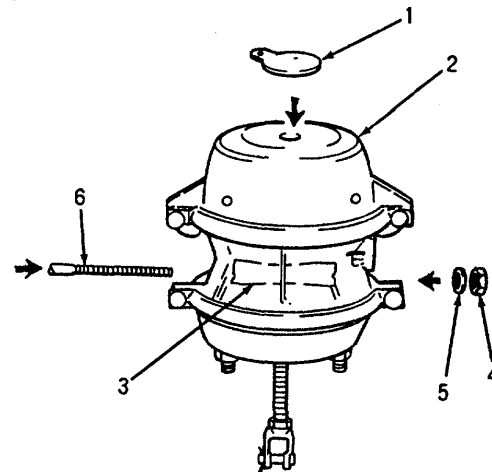

4. AFTER OPERATIONAL AIR PRESSURE BUILDS UP IN BRAKE CHAMBER AIR RESERVOIR, REMOVE RELEASE STUD ASSEMBLY FROM SPRING CHAMBER (2) AND STOW IN SIDE SLEEVE (3), BY INSERTING RELEASE STUD (8) THROUGH SIDE SLEEVE (3) AND INSTALL WASHER (5) AND NUT (4). REPLACE DUST CAP (1) ON SPRING CHAMBER (2).

FIGURE 2-77. RESETTING LOCKED) SPRING BRAKE (ARMY)

12-20. COLD WEATHER.

WARNING

Do not operate heater in fuel vapor areas or areas lacking adequate ventilation. Inhalation of fumes will result in serious illness or death.

Locating, installing and operating the equipment at subfreezing temperatures requires taking precautions. Adequate shelter and heating are required when operating in temperatures below 32°F (0°C). When locating the equipment, take advantage of existing shelter and windbreaks. Erect tenting shelters for protection. The filtered water storage tanks may be installed inside a tent or other shelter. Filtered water may be recirculated with the distribution pump between the two filtered water storage tanks to prevent freezing in the hose lines, tank outlets and pump. Fuel, coal or wood burning heaters or other heating devices may be installed inside the erected tents to protect the equipment and prevent freezing of water. When the equipment is to be shut down, all hoses must be disconnected from pumps, and all pumps, hoses, pipes and tanks drained quickly. All drain and vent valves must be opened and all equipment inspected to assure complete drainage. Leave covers on pumps. During cold weather, keep in mind the following warnings, cautions and procedures:

CAUTION

Turn valves slowly during cold weather, because metal contracts and becomes very brittle.

- a. Inspect the ROWPU closely for split or frozen hoses, clogged strainer, etc.

WARNING

To prevent hands from freezing to metal, wear rubber gloves when handling and setting valves.

CAUTION

If raw water hoses freeze, poor water flow will reduce pressure in R.O. pump. The R.O. PUMP LOW PRESSURE lamp will come on and R.O. pump will shut itself off. Bring hoses under cover until ice melts.

NOTE

The ROWPU produces less product water when the temperature of raw water drops.

- b. When the ROWPU is shut down during cold weather (temperature falls below 32°F (0°C), remove the R.O. elements (paragraph 3-4), and cartridge filters (paragraph 3-5). Store the elements indoors or in a tent where the temperature is above freezing and allow them to dry. Drain all water from ROWPU as follows:

WARNING

Make sure drained water runs toward lower ground (downstream) as far from the raw water source as possible.

- (1) Drain ROWPU pipe, filters, and connections:

- (a) Open seven drain valves (paragraph 2-7a).
- (b) Open five vent valves (paragraph 2-7b).

- (c) (ARMY) Facing trailer from towing end, jack-up left side to permit maximum water drainage through drain valves.

(2) Drain R.O. pump as described below:

CAUTION

Do not operate R.O. PUMP JOG switch (43, Figure 2-4) for more than 5 seconds at a time. You will damage pump if you do.

NOTE

The JOG switch can be used when the R.O. pump LOW PRESSURE lamp is on.

(a) After water stops flowing out of drains, push R.O. PUMP JOG switch to JOG. Hold it there for 3 to 5 seconds to force water from pump.

(b) Repeat operation of R.O. PUMP with JOG switch until no more water comes from the PULSE DAMPENER drain (figure 2-38).

(c) Open all front and rear R.O. sample valves (figure 2-41), and allow vessels to drain. Close sample valves when fully drained.

(d) Tag and disconnect the lines on the multimedia filter control valve (figure 2-14) and backwash timer pilot valve, and allow lines to drain. After draining the lines reconnect them to the valves as tagged.

(3) Drain booster pump: (a) Run BOOSTER PUMP for no more than 5 seconds (figure 2-55).

(b) Set switch to STOP.

(c) Repeat the last two steps until no more water comes from cartridge filter drain (figure 2-38).

(4) Drain chemical feed pumps as described below:

WARNING

Chemicals can cause sickness or death if extreme care is not taken. Wear protective devices when working with these solutions.

CAUTION

To avoid staining, be careful not to spill any solution on clothes or equipment. If any solution is spilled, it should be washed away immediately with water.

(a) Empty and rinse all chemical containers and fill them with brine water.

(b) Set chemical RUN/PRIME valves to PRIME (figure 2-63).

(c) Run pump motor to rinse chemical pumps. Ensure all control knobs (figure 2-10) are set to maximum setting.

- (d) Remove intake hose from all chemical containers.
 - (e) Allow pump to run (38, figure 2-4) for 5 to 10 seconds to empty water from chemical pumps.
 - (f) Stop pump motor and empty chemical containers.
 - (g) Set chemical pump valves to PRIME position.
 - (h) Remove all hoses from pump and drain.
- (5) Drain distribution pump and raw water pumps No. 1 and No. 2:
- (a) Disconnect inlet and outlet hoses from pumps.
 - (b) Tip pumps toward each connection to permit drainage.
 - (c) Open pump vent valve on raw water pumps No: 1 and No. 2 (figure 2-39).
 - (d) Open pump drain valve on raw water pumps No. 1 and No. 2 (figure 2-38).
 - (e) Run pumps (39-41, figure 2-4) for less than 5 second intervals until all water is out.
 - (f) Shut off pumps.
- (6) Drain backwash pump:
- (a) Disconnect backwash suction hose at backwash pump.
 - (b) Open draincock on bottom of backwash pump. Drain pump and backwash strainer.
 - (c) Close draincock on pump.

12-21. HOT WEATHER.

- a. When the air temperature is 90°F (32°C) or above, park in the shade and leave canvas cover open and over the ROWPU. Leave control panel uncovered.

NOTE

The motors will automatically shut off if they overheat.

- b. Check raw water and product water more often during hot weather.

NOTE

Plant life in water will clog multimedia filter and, therefore, reduce time between filter backwashings during hot weather.

- c. Carefully inspect wire insulation for damage.

2-22. DUSTY AND SANDY AREAS.

- a. Protect equipment. Leave side covers down except over control panel.
- b. Keep ground around ROWPU damp to prevent loose, blowing sand and dirt.
- c. Cover all water storage tanks and chemical pails.

2-23. RAINY AND DAMP AREAS.

CAUTION

To avoid electrical shorts, keep electrical items dry.

- a. Provide good water drainage.
- b. Protect chemicals.

2-24. SALTWATER AREAS.

- a. When preparing for movement after saltwater operations, perform PREPARATION FOR MOVEMENT procedure (paragraph 2-16a).
- b. After backwash is completed, drain brine tank and set chemical feed control valves to PRIME. Place the product water discharge hose into the brine water tank. Operate the ROWPU to produce nonchlorinated product water (minimum 1,000 gallons).
- c. When the tank is full or the minimum requirement is met, shut down the ROWPU (paragraph 2-14).
- d. Remove the raw water strainer and hose from the source and place it in the tank of NONCHLORINATED product water.
- e. Follow INITIAL ADJUSTMENTS AND CHECKS (paragraph 2-7) and OPERATING PROCEDURE (paragraph 2-9), except for moving the chemical feed valves to RUN(NO CHEMICALS SHOULD BE INJECTED INTO THE SYSTEM DURING THIS PROCEDURE), until the nonchlorinated tank is empty.
- f. Shut down the ROWPU following SHUTDOWN PROCEDURES (paragraph 2-14).

This procedure should be used to flush the salt deposits and bacteria from the system and the RO elements. By flushing this from the system, it slows corrosion and bacterial growth.

2-25. NUCLEAR OR CHEMICAL CONTAMINATED AREAS:

- a. The ROWPU has overpack items which are used as a post-treatment when nuclear or chemical contaminants are present. The equipment consists of a cartridge to remove nuclear contaminants, a cartridge used to remove chemical contaminants, and the adapters, bushing, clamps, couplings, reducers, and tubing needed for assembly.

WARNING

Radioactive contaminants are potentially hazardous. Use extreme care in replacing cartridge and follow safe procedures in their handling and disposal.

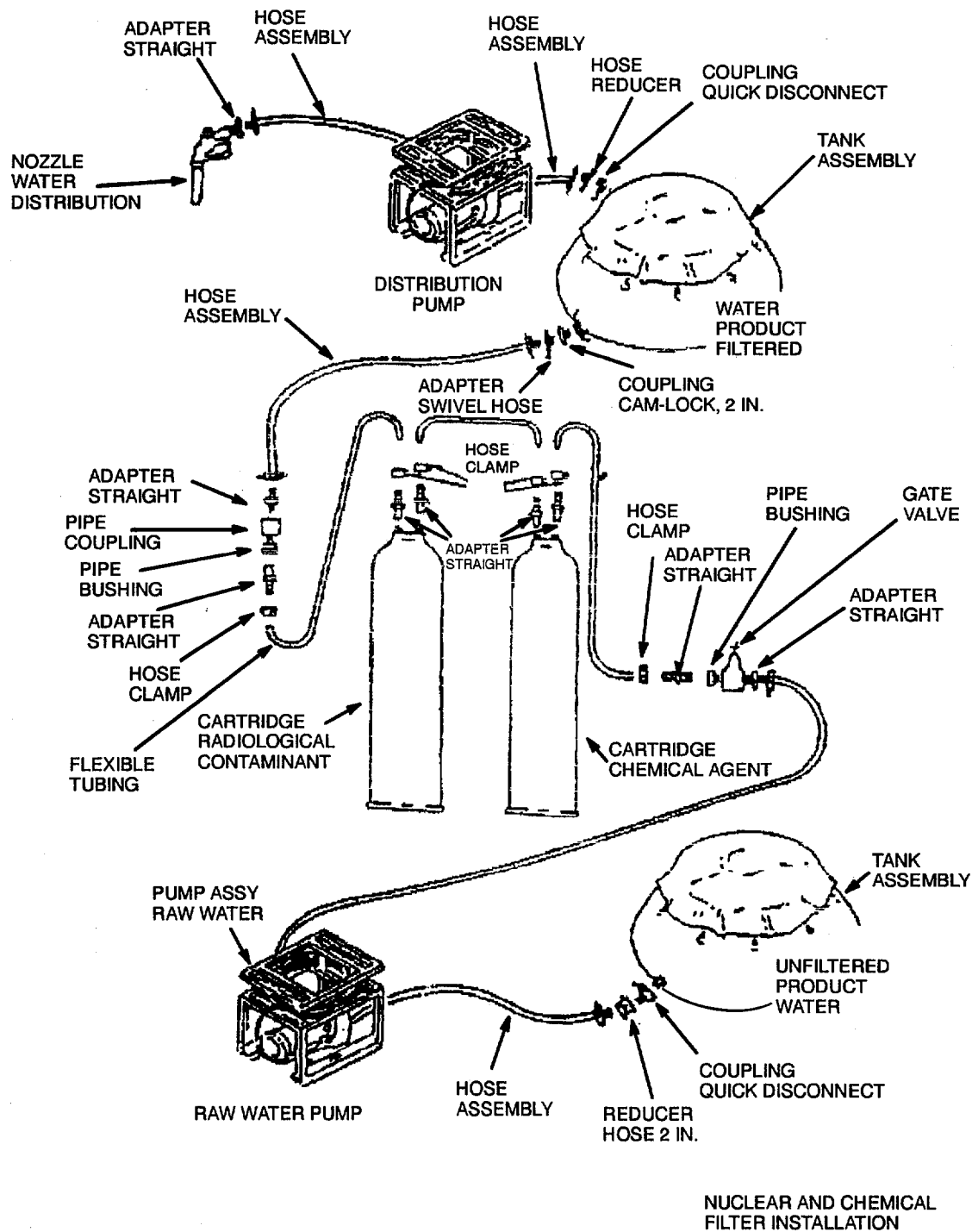

FIGURE 2-78. NUCLEAR AND CHEMICAL FILTER INSTALLATION

NOTE

Do not operate chlorination feed pump during NBC operation.

- b. For nuclear biological OR chemical contamination, use BOTH the cartridge marked "FOR USE WITH RADIOACTIVE CONTAMINATED WATER ONLY" AND the cartridge marked "FOR USE WITH CHEMICALLY CONTAMINATED WATER ONLY."
- c. Exchange the inlet and outlet raw water pump adapter which is used in the NBC system and prepare to assemble NBC filters between two raw water tanks as shown in (figure 2-78).
- d. Use one of the raw water pumps to force the water through the NBC cartridges. Install raw water pump (figure 2-78).
 - (1) Install 1 1/2 in. suction hose from raw water tank and swivel adapter on raw water pump.
 - (2) Attach female end of distribution (suction or discharge) hose to straight adapter on raw water pump.
 - (3) Attach swivel adapter to gate valve and attach male end of distribution hose to swivel adapter.
 - (4) Attach shoulder bushing and adapter to gate valve.

NOTE

The NBC cartridges should be positioned so that the cartridge marked "FOR USE WITH CHEMICALLY CONTAMINATED WATER ONLY" is FIRST in the series. Position the cartridge marked "FOR USE WITH RADIOACTIVE CONTAMINATED WATER" so that water is filtered through this cartridge LAST as shown in (figure 2-78).

- e. Assemble the NBC cartridges in series (figure 2-78).

WARNING

Be sure to follow the setup procedures in steps 1 through 4 below. Pay special attention to the INPUT and OUTPUT labels on the top of the NBC cartridges when connecting the 3/4 in. reinforced flexible tubing to the cartridges.

- (1) Slide clamp over end of one section of 3/4 in. x 80 in. flexible tubing, attach tubing to adapter on gate valve and close clamp.
- (2) Slide clamp over other end of tubing.
- (3) Remove plug from INLET port on FOR USE WITH CHEMICALLY CONTAMINATED WATER cartridge and insert adapter.
- (4) Attach tubing to adapter on INLET port and close clamp.
- (5) Cut one section of 3/4 in. x 80 in. flexible tubing to a maximum length of 24 in.
- (6) Slide clamp over end of tubing.
- (7) Remove plug from OUTLET port on FOR USE WITH CHEMICALLY CONTAMINATED WATER cartridge and insert adapter into cartridge.
- (8) Attach tubing to adapter on OUTLET port and close clamp.

- (9) Remove plug from INLET port on FOR USE WITH RADIOACTIVE CONTAMINATED WATER cartridge and insert adapter into cartridge.
 - (10) Slide clamp over end of tubing.
 - (11) Attach tubing to adapter on INLET port and close clamp.
 - (12) Slide clamp over end of second section of 3/4 in. x 8 in. flexible tubing.
 - (13) Remove plug from OUTLET port on FOR USE WITH RADIOACTIVE CONTAMINATED WATER cartridge and insert adapter.
 - (14) Attach tubing to adapter on OUTLET port and close clamp.
- f. Complete connection of NBC cartridge to second raw water tank (figure 2-78).
- (1) Slide clamp over remaining end of 3/4 in. x 80 in. flexible tubing.
 - (2) Insert adapter into tubing and close clamp.
 - (3) Attach shoulder bushing, pipe coupling, and straight adapter to 1 1/2 in. discharge hose and connect to second raw water tank (figure 2-78).

NOTE

Do not operate chlorination feed pump during NBC operation.

- g. During NBC operation, it is necessary to chlorinate the second tank by hand.
- h. With the exception of the chlorination feed pump, operate the ROWPU using normal operating procedures.

CHAPTER 3
MAINTENANCE INSTRUCTIONS
INTRODUCTION

Section I. LUBRICATION INSTRUCTIONS

3-1. LUBRICATION ORDER.

For lubrication instructions for the flatbed cargo trailer and ROWPU refer to Lubrication Orders LO 10-4610-240-12/LI08580C-12/T40W4-13-31.

Section II. TROUBLESHOOTING PROCEDURES

3-2. TROUBLESHOOTING TABLE.

To troubleshoot, refer to tables 3-1 and 3-2.

a. Each table lists the common malfunctions which may be encountered during the operation or maintenance of the flatbed trailer and the ROWPU. Perform the test/inspection and corrective actions in the order listed.

b. This manual cannot list all malfunctions that may occur, nor all tests or inspections and corrective actions. If a malfunction is not listed or is not corrected by listed corrective actions, notify the appropriate supervisor.

Table 3-1. (ARMY) Troubleshooting (Trailer)

MALFUNCTION	TEST OR INSPECTION	CORRECTIVE ACTION
-------------	--------------------	-------------------

ELECTRICAL

1. LIGHTS DON'T WORK

Step 1. Manually check trailer cable for proper connection to receptacle on towing vehicle.

Connect cable properly.

Step 2. Visually check both receptacles on towing vehicle and plug on cable to be sure all contacts are free of dirt, oil, and other contaminants.

Check for damaged receptacle.

a. Clean all connectors to remove corrosion and contaminants.

b. If receptacle is damaged, refer to unit maintenance.

Table 3-1. (ARMY) Troubleshooting (Trailer) - Continued

MALFUNCTION	TEST OR INSPECTION	CORRECTIVE ACTION
1. LIGHTS DON'T WORK. (Continued)		
Step 3.	Visually and manually check wiring harness for loose or corroded connections, or damaged cable.	a. Tighten loose connections. b. Clean corroded connections. c. If cable is damaged, refer to unit maintenance.
Step 4.	Visually check ground connection to receptacle and check ground wire to towing vehicle. If ground wire is loose or making poor contact, reposition wire and tighten connections.	
Step 5.	Visually check all lamps.	a. Replace all burnt out lamp(s). b. If lamps are not defective, notify unit maintenance of trouble.
2. LIGHTS OPERATE INTERMITTENTLY.		
Step 1.	Visually and manually check cable assembly connectors and towing vehicle mating receptade connections for proper contact. Tighten all connectors to ensure proper contact.	
Step 2.	Visually check all contacts for contaminants such as oil, water, dirt, corrosion. Clean all connectors to remove corrosion and contaminants.	
Step 3.	Visually check entire cable assembly for partially severed cable. If cable is damaged, refer to unit maintenance.	
Step 4.	Check that ground wires on trailer and towing vehicle are making proper contact. Clean ground wire connections and secure tightly as necessary.	

Table 3-1. (ARMY) Troubleshooting (Trailer) - Continued

MALFUNCTION	TEST OR INSPECTION	CORRECTIVE ACTION
-------------	--------------------	-------------------

3. LIGHTS ARE DIM.

Step 1. Check trailer cable to be sure there are no damaged or broken wires, or corrosion on contacts.

Check ground wire on both the trailer and on the towing vehicle.

- a. If cable is damaged, refer to organizational maintenance.
- b. If cable is not damaged, clean all contacts to remove contaminants.
- c. Clean and tighten ground connections.

Step 2. Check that correct lamps are installed, and securely seated in their sockets.

- a. Replace incorrect lamps with correct type.
- b. Tighten lamps found loose in their sockets.
- c. If trouble is still present, refer to organizational maintenance.

4. WRONG LIGHT GOES ON.

Step 1. Will require a check of the cable assembly coding and voltages.

Notify organizational maintenance.

AIR BRAKE SYSTEM

1. SYSTEM INOPERATIVE.

Step 1. Inspect air line hookup to be sure lines are not crossed.

Disconnect air lines and reconnect correctly.

Step 2. Listen for escaping air, and locate defective line or fixture.

Notify organizational maintenance.

Table 3-1. (ARMY) Troubleshooting (Trailer) - Continued

MALFUNCTION	TEST OR INSPECTION	CORRECTIVE ACTION
1. SYSTEM INOPERATIVE. (Continued)		
	Step 3.	Check the air system of the towing vehicle for leaks or lack of pressure. Notify organizational maintenance.
2. BRAKES REMAIN LOCKED.		
	Step 1.	Check for cause of the lack of air pressure. Notify organizational maintenance.
	Step 2.	Check the operation of the emergency/relay valve. Notify organizational maintenance.
	Step 3.	Check to see if the compression springs have locked the brakes (wheels will not turn if springs have locked). Locate and correct the cause of the loss of air pressure; then refer to figure 2-77 in this manual for instructions for resetting a locked spring brake.
3. BRAKES ON ONE SIDE ENGAGE BEFORE THOSE ON THE OTHER SIDE.		
	Step 1.	Check the movement of the slack adjusters to see if they are out of adjustment. Notify organizational maintenance.
	Step 2.	Check the brake camshaft movement to see if there is any restriction on movement. Notify organizational maintenance.
4. BRAKES SLIP.		
	Step 1.	Check brake adjustment, and inspect for defective brake assembly parts. Notify organizational maintenance to adjust brakes or replace defective parts.

Table 3-2. Troubleshooting (ROWPU)

MALFUNCTION	TEST OR INSPECTION	CORRECTIVE ACTION
1. ANY PUMP LAMP GOES OFF.		
Step 1.	Test control panel lamps using TEST INDICATOR LIGHTS switch (figure 2-4) on control panel.	Replace defective bulb using lamp puller (paragraph 3-10).
Step 2.	Check to see if associated pump is operating. For R.O. pump, see if sheave is turning; for other pumps, rest hand lightly on the motor casing to feel for motor vibrations.	
	a. If pump is not operating, check and reset respective circuit breaker in junction box and then immediately try to restart pump. Do so only one time.	
	b. If pump fails to start, notify organizational maintenance.	
	c. Shut down ROWPU in normal manner (paragraph 2-14) except when only one raw water pump fails or distribution pump fails. In these two cases the ROWPU can still be operated.	
2. RAW WATER FLOW INDICATOR DROPS TO NEAR ZERO; BOTH RAW WATER PUMP LAMPS ARE ON.		
Step 1.	Check to see that both raw water pumps are operating. Listen to motor and rest hand lightly on motor casing to feel for vibration.	
	a. If pump is not operating, check and reset circuit breaker (figure 2-4) and then immediately attempt to restart. Do so only one time.	
	b. If pump fails to start, notify organizational maintenance and remove defective raw water pump from cycle.	
Step 2.	Check for loose hose connections or damaged hose sections.	
	a. Tighten loose connections.	
	b. Replace damaged hose sections.	
Step 3.	Check to see if input strainer is completely under water.	
	a. Lengthen strainer rope.	
	b. Move intake to deeper water.	

Table 3-1. Troubleshooting (ROWPU) (Continued)

MALFUNCTION	TEST OR INSPECTION	CORRECTIVE ACTION
-------------	--------------------	-------------------

2. ON. RAW WATER FLOW INDICATOR DROPS TO NEAR ZERO; BOTH RAW WATER PUMP LAMPS ARE (Continued)

- Step 4. Check to see if input strainer is clogged.
- a. Clean debris from input strainer.
 - b. Shorten strainer rope so it does not rest on bottom of raw water source.
 - c. Make sure raw water pump is sufficiently close to raw water source.
- Step 5. Check for kinked hoses.
- Unkink hoses.

3. CARTRIDGE FILTER GAUGE RISE ABOVE 20 PSID.

- Step 1. Make a turbidity tube check (paragraph 2-9p) of water taken from DRAIN NO. 1 CARTRIDGE FILTER valve (Figure 2-38).
- a. If water is turbid, shut down ROWPU in normal manner (paragraph 2-14) and change cartridge filter elements (paragraph 3-5).
 - b. If water is clear, notify unit maintenance because gauge may be defective.

4. 500 REDUCED PRODUCT WATER FLOW; R.O. PRESSURE PSI ADJUSTED TO 960 FOR SALTWATER, FOR FRESH AND BRACKISH WATER.

NOTE

ROWPU produces less product water when raw water source temperature drops (1.6% less per degree fahrenheit drop).

- Step 1. Check R.O. vessels for leaks caused by loose end caps or defective end cap O-rings.
- a. Tighten loose nuts (paragraph 3-4h(15)).
 - b. Replace defective end cap O-rings (see paragraph 3-4c elements need not be replace).
- Step 2. Check R.O. vessel gauge for reading higher than 100 psid.

NOTE

Membrane scaling may cause reduced product water flow without increasing R.O. vessels pressure. Cleaning elements when vessel pressure is under 100 psid may improve flow.

- a. Clean R.O. elements (paragraph 2-12).

Table 3-2. Troubleshooting (ROWPU) (continued)

MALFUNCTION	TEST OR INSPECTION	CORRECTIVE ACTION
-------------	--------------------	-------------------

5. PRODUCT WATER FLOW READING RISES ABOVE 16 GPM (FRESH/BRACKISH), 12 (SEAWATER) AND CANNOT BE LOWERED USING REGULATE PRODUCT FLOW VALVE.

- Step 1. Check the TDS of product water from each R.O. vessel: **WARNING** Water is under pressure and will discharge rapidly. **DO NOT** disconnect product water hoses.
- a. Use sample valves (figure 2-41) to collect product water sample. **Do NOT** disconnect product water hoses.
 - b. Check TDS of sample from each R.O. vessel using TDS meter without range extender (paragraph 2-15c(5)).

c. Use readings to make a chart similar to the following:

R.O. Vessel	TDS (ppm)
1 (-Top)	600
2	900
3	1100
4 (Bottom)	1400

NOTE
 Numbers on chart are examples only. Yours may vary.

- d. Examine pattern of chart. TDS readings should get larger from top to bottom.
 - (1) If any R.O. vessel does not follow this pattern, there is something wrong inside; disassemble faulty vessel and replace defective items (paragraph 3-4).
 - (2) If R.O. vessels all follow this pattern, proceed to Step 2.

- Step 2. Check product water flow from each R.O. vessel.
- a. Use same method as in Step 1 to collect product water sample, but this time measure the time in minutes it takes to fill a 3-gallon bucket with product water from each vessel. Divide 3 by the number of minutes.

Table 3-2. Troubleshooting (ROWPU) (continued)

MALFUNCTION	TEST OR INSPECTION	CORRECTIVE ACTION
-------------	--------------------	-------------------

5. **PRODUCT WATER FLOW READING RISES ABOVE 16 GPM (FRESH/BRACKISH), 12 (SEAWATER) AND CANNOT BE LOWERED USING REGULATE PRODUCT FLOW VALVE. (Continued)**

b. Make a chart like the following:

R.O. Vessel	FLOW (gpm)
1 (-Top)	4
2	3
3	2
4 (Bottom)	1

c. Examine your chart for a similar pattern. flow rate should get smaller from top to bottom.

- (1) If any R.O. vessel does not follow this pattern, disassemble that vessel and replace defective items (paragraph 3-4).
- (2) If all vessels follow this pattern, notify unit maintenance to check for defective PRODUCT FLOW indicator.

6. **R.O. PRESSURE PSIG. GOES ABOVE 960 PSI IN SALTWATER OPERATION, 500 IN FRESH OR BRACKISH WATER OPERATION.**

Step 1. Check TDS of product water (paragraph 2-4).

- a. If TDS over 1500 ppm, shut down ROWPU in normal manner (paragraph 2-14) and clean R.O. elements (paragraph 2-13).
- b. If TDS below or at 1500 ppm, notify unit maintenance of possible defective pressure gauge.

7. **BACKWASH PUMP RUNS CONTINUOUSLY.**

Step 1. Check position of R.O. ELEMENT CLEANING switch. Switch must be off except during R.O. element cleaning.

Turn ELEMENT CLEANING switch to OFF position.

Table 3-2. Troubleshooting (ROWPU) (continued)

MALFUNCTION	TEST OR INSPECTION	CORRECTIVE ACTION
7.	BACKWASH PUMP RUNS CONTINUOUSLY. (Continued)	
	Step 2. Notify unit maintenance to troubleshoot BACKWASH TIMER and its electrical wires.	
8.	BACKWASH WATER FLOW READING DROPS TO NEAR ZERO DURING BACKWASH OPERATION; BACKWASH PUMP LAMP IS ON.	
	Step 1. Check for closed or clogged valve on tank.	
	a. Open closed valve by turning handle fully to the left until it stops (counterclockwise).	
	b. Clean clogged valve.	
	Step 2. Check for clogged strainer or BACKWASH PUMP suction opening (paragraph 36).	
	a. Flush strainer with product water to remove debris.	
	b. Remove debris from suction opening.	
	Step 3. Check level of water in backwash water tank.	
	NOTE	
	There is a period of about 15 seconds when the flow gauge will drop to "0" before returning to normal reading. This is normal.	
	If water level is below backwash pump intake, immediately shut off backwash pump. Patch any leaks in backwash water tank (refer to TM 5-5430-227-12&P). Fill tank with raw water and continue backwash operation.	
	Step 4. Check for leaking hose.	
	Replace defective hose.	
	Step 5. Check for kinked hoses.	
	Unkink hoses.	

Table 3-2. Troubleshooting (ROWIPU) (continued)

MALFUNCTION	TEST OR INSPECTION	CORRECTIVE ACTION
9. DISTRIBUTION NOZZLE DELIVERS LITTLE OR NO PRODUCT WATER; DISTRIBUTION PUMP LAMP IS ON.	Step 1. Check for water level below distribution pump intake in product water tank.	a. Patch any leaks in product water tanks. b. Continue operations to produce product water.
	Step 2. Check for loose hose connections or leaking hose.	a. Tighten loose connections. b. Replace leaking hose.
	Step 3. Check distribution nozzle for broken parts or inoperative handle. Replace defective distribution nozzle.	
	Step 4. Check for kinked hoses. Unkink hoses.	
10. PUMP LAMP ON CONTROL BOX ASSEMBLY DOES NOT LIGHT WHEN SWITCH IS SET TO START.		
	NOTE	
	Step 1 applies only to normal start of the raw water pump. If other pump lamps do not light when started in proper order, go to step 2.	
	Step 1. Ensure the EMERGENCY STOP button is pulled out.	Pull EMERGENCY STOP button out.
	Step 2. Check to see if ROWPU is receiving power from power source. R.O. pump LOW PRESSURE LAMP should be on and panel light should work if ROWPU is receiving power.	a. Operate TEST INDICATOR LIGHT switch. If no lights come on, make sure power source is securely plugged into junction box. b. Troubleshoot power source using applicable manual.

Table 3-2. Troubleshooting (OWPU) (continued)

MALFUNCTION	TEST OR INSPECTION	CORRECTIVE ACTION
-------------	--------------------	-------------------

10. PUMP LAMP ON CONTROL BOX ASSEMBLY DOES NOT LIGHT WHEN SWITCH IS SET TO START.
 (Continued)

Step 3. Check to see if associated pump is operating. For R.O. pump, see if sheave is turning; for other pumps, check for correct pump rotation.

- a. If motor is running, replace switch indicator lamp bulb (paragraph 3-9).

NOTE

If new bulb does not light, notify unit maintenance to troubleshoot lamp socket and wiring.

- b. If motor is not running, go to step 4.

WARNING

Electric shock can cause severe injury or death. Do not touch anything in the junction box except the circuit breaker handle.

Step 4. Check circuit breakers.

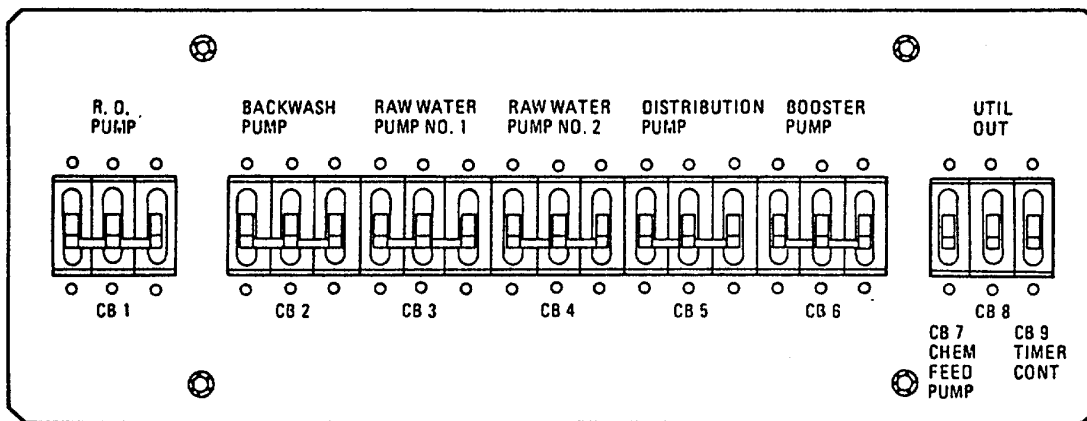

- a. Reset circuit breaker.
- b. Attempt to start pump.
- c. If pump will not start, notify unit maintenance.

Table 3-2. Troubleshooting (ROWPU) (continued)

MALFUNCTION	TEST OR INSPECTION	CORRECTIVE ACTION	
11. R.O. PUMP SHUTS DOWN BY ITSELF; R.O. PUMP LOW PRESSURE LAMP COMES ON.	Step 1. Check to see if booster pump is operating.	a. If pump is not operating, reset circuit breaker if necessary and try to restart pump. If pump will not start, notify unit maintenance. b. If booster pump is operating, check for clockwise rotation (from fan end).	
	Step 2. Check to see if cartridge filter gauge reads over 20 psid. If over 20 psid, change filter elements (paragraph 3-5).		
	Step 3. Check RAW WATER gauge for normal flow. a. If low flow exists, move raw water pump closer to source. b. If raw water flow is normal, go to step 4.		
	Step 4. Check to see if MULTIMEDIA FILTER gauge has risen 5 psid over reading at startup. a. If yes, backwash multimedia filter (paragraph 2-10). b. If no, go to step 5.		
	Step 5. Make turbidity test of water taken from DRAIN NO. 1 CARTRIDGE FILTER valve (figure 2-38). a. If water is turbid, shut down ROWPU in normal manner (paragraph 2-14) and change cartridge filter elements (paragraph 3-5). b. If water is clear, notify unit maintenance.		
	12. R.O. PUMP SHUTS DOWN AUTOMATICALLY; R.O. PUMP HIGH PRESSURE LAMP GOES ON.		CAUTION
			If HIGH PRESSURE RELIEF VALVE did not activate before R.O. PUMP HIGH PRESSURE switch, notify unit maintenance.

Table 3-2. Troubleshooting (ROWPU) (continued)

MALFUNCTION	TEST OR INSPECTION	CORRECTIVE ACTION
12. R.O. PUMP SHUTS DOWN AUTOMATICALLY; R.O. PUMP HIGH PRESSURE LAMP GOES ON. (Continued)		
	Step 1. Check to see if R.O. PRESSURE PSI gauge is over 11 50 P.S.I.	
		a. Clean R.O. elements (paragraph 2-13) then attempt to restart R.O. pump. b. If R.O. PUMP RESET switch does not turn off R.O. PUMP HIGH PRESSURE lamp, there may be a defective switch. Notify unit maintenance.
13. BACKWASH PUMP DOES NOT START WHEN START BACKWASH SWITCH IS SET TO START.		
	Step 1. Check that circuit breaker BACKWASH PUMP CB2 is set to on (up).	
		Reset circuit breaker BACKWASH PUMP CB2 to on (up).
	Step 2. Open back wash timer cover and press OVERCURRENT PROTECTION PUSH TO RESET switch (figure 2-70).	
		a. Check power cable to backwash timer for connections. b. If backwash cycle still will not start, notify unit maintenance.
14. MULTIMEDIA FILTER VENT LINE DOESN'T DISCHARGE WATER.		
	Step 1. Check vent line for obstruction.	
		Notify unit maintenance.
15. CHEMICAL FEED PUMP FAILS TO OPERATE.		
	Step 1. If pump fails to prime after setting control knob to max (100). Check the plastic suction line from the container to the pump.	
		Notify unit maintenance.

Table 3-2. Troubleshooting (ROWPU) (continued)

MALFUNCTION	TEST OR INSPECTION	CORRECTIVE ACTION
-------------	--------------------	-------------------

16. PRODUCT WATER TOTAL DISSOLVED SOLIDS (TDS) LEVEL IS ABOVE 1500 PPM.

Step 1. Check product water from each pressure vessel as follows:

- a. Start up ROWPU as normal (paragraph 2-9).
- b. Adjust R.O. PRESSURE to 960 psig. for sea water feed or 500 psig for fresh/brackish water feed. Collect a sample of product water in a clean container and measure TDS with portable TDS meter (paragraph 2-15). Record value.
- c. Using sample valves, collect sample product water from each vessel.
- d. Using clean containers, collect a sample of product water from each end of R.O. Vessel 1. Be sure to rinse each container twice with sample water before collecting sample. Mark container appropriately as front or rear.
- e. Measure TDS of each product water sample using the TDS meter (paragraph 2-15).
- f. Based on the TDS measurements of the collected samples, one of the following four conditions can exist:

CONDITION	MEASURED TDS		CAUSE
	FRONT SAMPLE	REAR SAMPLE	
1	NORMAL	NORMAL	Vessel operation OK
2	HIGH	NORMAL	Leak at front end-connector O-rings*
3	NORMAL	HIGH	Leak at rear end-connector O-rings*
4	HIGH	HIGH	Leak at front and rear end-connector O-rings and/or R.O. element interconnector O-rings*
			*Condition could also be caused by defective R.O. element.

Condition 1: Repeat steps c through h for all remaining vessels to determine the correct source(s) of high TDS.

Table 3-2. Troubleshooting (ROWPU) (continued)

MALFUNCTION	TEST OR INSPECTION	CORRECTIVE ACTION
16. PRODUCT WATER TOTAL DISSOLVED SOLIDS (TDS) LEVEL IS ABOVE 1500 PPM. (Continued)		
Condition 2:	Remove front end cap and end-connector and check condition, lubrication, and size of O-rings. Replace damaged or wrong-size O-ring(s) with lubricant found in Storage Box No. 2 before installation. Carefully reinstall end-connector and end cap per paragraph 3-4h.	
Condition 3:	Remove rear end cap and end-connector and check condition, lubrication, and size of O-rings. Replace damaged or wrong-size O-ring(s), lubricating O-rings with lubricant found in Storage Box No. 2 before installation. Carefully reinstall end-connector and end cap per paragraph 3-4h.	
Condition 4:	Remove the R.O. elements from the pressure vessel per paragraph 3-4. Check condition, lubrication, and size of all O-rings. Replace damaged or wrong-size O-ring(s), lubricating O-rings with lubricant found in Storage Box No. 2 before installation. Carefully install elements and end caps per paragraph 3-4h.	
		<ul style="list-style-type: none"> g. Adjust R.O. PRESSURE to 960 psig (seawater) or 500 psig brackish water). h. For each R.O. vessel in which O-rings were inspected, collect a sample of product water from each end of vessel, rinsing each container twice with sample water before collecting sample. Do one vessel at a time. Mark container appropriately as front or rear. i. Measure TDS of each product water sample (paragraph 2-15c(5)). If one or both samples are still high, leaky O-rings or faulty (cracked) connectors may still be present, or one or both R.O. elements may be faulty. Depending upon availability of time, either repeat steps a through l or replace the elements (paragraph 3-4). j. Resume normal operation.
Step 2.	R.O. elements may be scaled or fouled. Clean R.O. elements (paragraph 2-12).	

Section III. MAINTENANCE PROCEDURES

3-3. INTRODUCTION.

This section provides maintenance procedures to be performed by the operator.

3-4. CHANGING R.O. ELEMENTS.

a. General. The R.O. elements are replaced any time TDS of product water exceeds 1500 parts per million and cannot be corrected by using procedures described in item 16, table 3-2, Troubleshooting. Each R.O. vessel contains two R.O. elements.

CAUTION

If removing end caps from more than one R.O. vessel, mark end caps with pencil or chalk to ensure they are replaced on correct vessel and correct end.

To reduce chances of leaks, mark end caps and vessel (alignment marks) with chalk or pencil so that end caps are installed in the same position.

CAUTION

Shutdown ROWPU and relieve all pressure before removing the R.O. elements, or loosening any parts of the R.O. pressure vessels.

NOTE

Some steps require 2 people.

b. Pre-removal Procedures.

- (1) Shut the ROWPU down normally (paragraph 2-14).
- (2) Open all R.O. vents, drains, and valves.

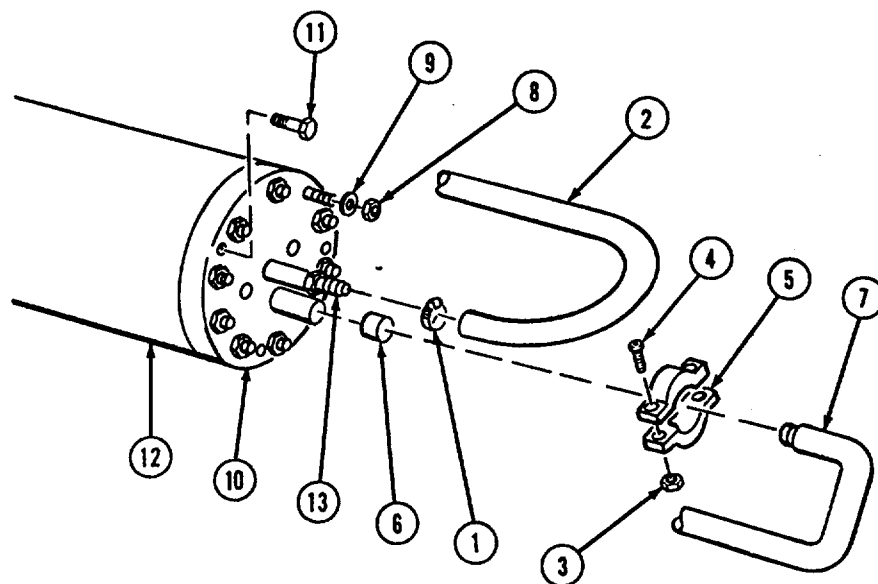

LEGEND:

1. HOSE CLAMP
2. HOSE
3. NUT
4. BOLT
5. CLAMP
6. GASKET
7. ELBOW
8. NUT
9. WASHER
10. ENDCAP
11. PULLER BOLTS
12. PRESSURE TUBE
13. ADAPTER

FIGURE 3-1. R.O. VESSEL, END CAP ASSEMBLY REMOVAL

- c. End Cap Assembly Removal (Refer to figure 3-1).

NOTE

To aid movement of piping during end cap removal, remove forward end caps first.

- (1) Loosen hose clamp (1) and remove hose (2) from adapter (13).
- (2) Remove nuts (3), bolts (4), clamps (5), and gasket (6) from elbow (piping) (7).
- (3) Swing elbow (7) away from end cap (10).
- (4) Remove nuts (8) and washers (9) from end cap (10).

CAUTION

Use extreme caution when separating end cap from vessel. Pressure tube studs and seal are easily damaged. Do not attempt to pry end cap from pressure tube.

- (5) Screw four end cap puller bolts (11) into threaded holes in end cap (10). Turn puller bolts alternately until end cap is separated from pressure tube (12). Slowly, separate end cap from vessel.
- (6) Repeat steps (1) through (5) for opposite end cap.

d. **Element Puller Assembly** (Refer to figure 3-2).

- (1) Assemble element puller by screwing together the puller rod (1) and puller rod handle (2).

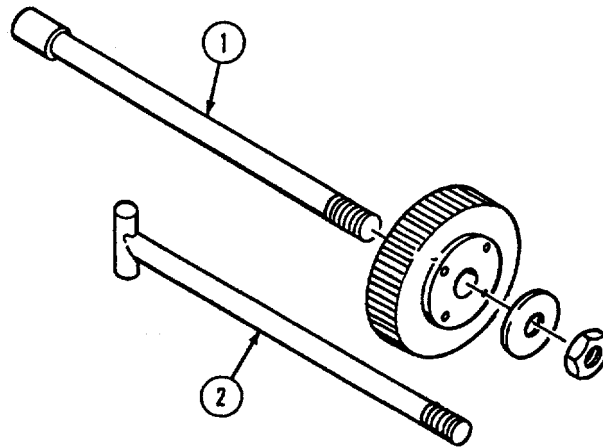

LEGEND:

1. PULLER ROD
 2. PULLER ROD HANDLE

FIGURE 3-2. R.O. VESSEL, ELEMENT PULLER

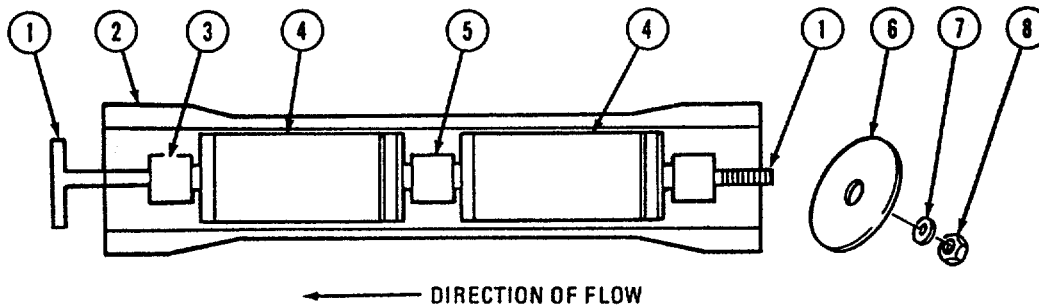

LEGEND:

- | | |
|-------------------------------|-------------------------|
| 1. ELEMENT PULLER (ASSEMBLED) | 5. INTERCONNECTOR |
| 2. R.O. VESSEL | 6. ELEMENT PULLER PLATE |
| 3. END CONNECTOR | 7. FLAT WASHER |
| 4. R.O. ELEMENTS | 8. NUT |

FIGURE 3-3. R.O. VESSEL ELEMENT PULLER ASSEMBLY

NOTE

If possible, remove elements in direction of flow. Because of obstruction by generator, ARMY users must remove and install elements from trailer hitch end.

MC and AF users must remove top and second from bottom elements from R. O. pump end, and install from chemical feed pump end. The bottom and second from top elements are removed from chemical feed pump end and installed from R. O. pump end.

(2) Refer now to figure 3-3. From the front of the ROWPU, insert element puller (1) into R. O. vessel (2). Push puller through end connector (3), through the two R. O. elements (4), and through the interconnector (5) between the two R. O. elements.

(3) Place element puller plate (6) on assembled element puller (1) and secure with flat washer (7) and nut (8).

(4) After inserting the element puller into the R. O. elements and attaching the element puller plate, the assembly will be as shown (figure 3-4).

e. Removal. (Refer to figure 3-4).

(1) Slowly pull both R.O. elements (1) from R.O. vessel (2), while someone else supports assembly to keep element puller centered in tube.

NOTE

Placing one hand on frame while pulling with the other hand may help to keep the element puller centered.

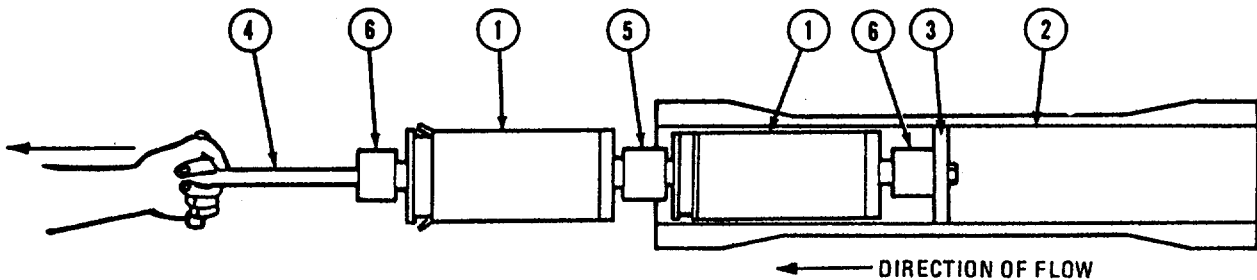

LEGEND

1. R.O. ELEMENTS

2. R.O. VESSEL

3. ELEMENT PULLER PLATE

4. ELEMENT PULLER

5. INTERCONNECTOR

6. END CONNECTORS

FIGURE 3-4. PULLING ELEMENT FROM R.O. VESSEL

(2) Disconnect the element puller plate (3) and remove element puller (4) from R.O. elements (1). With one person on either end of assembly, twist and pull elements apart.

f. Inspection.

(1) Inspect inside R.O. vessels for nicks and gouges.

(2) Check interconnector and both end connectors for deep scratches and cracks.

(3) Check brine seals and O-rings for cracks and tears.

g. Cleaning.

(1) Flush dirt from inside R.O. vessels using the brine water.

(2) Wipe any dirt from interconnector or end connectors using a clean cloth.

h. Installation (Refer to figure 3-5).

NOTE

Remove puller bolts (11, figure 3-1) from end cap (10).

- (1) Lubricate O-rings with O-ring lubricant from Storage Box No. 2.

NOTE

There is a smaller and a bigger sized O-ring on the end connectors. The side of the end connector which will fit on end of R. O. element has a lip on the inside. This side of end connector has the bigger O-ring. The interconnector O-rings are the same size as the bigger end connector O-rings.

- (2) Install O-rings (1) and (3) in end connectors (2) and two O-rings (3) in interconnector (5).

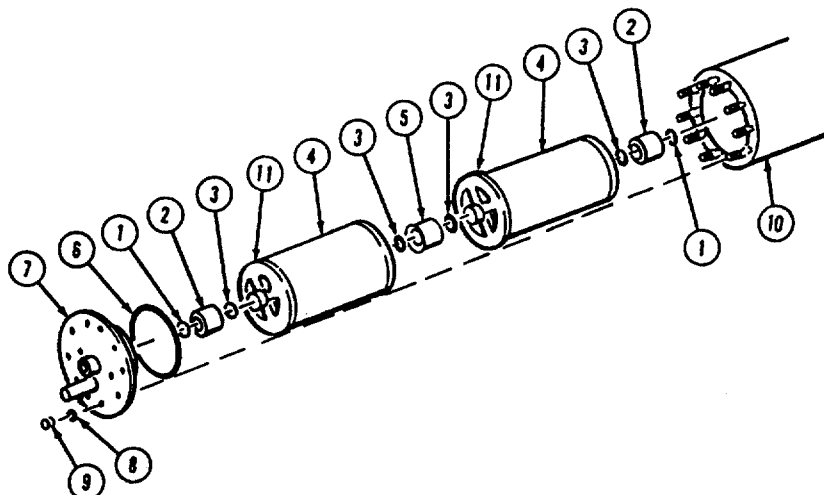

LEGEND:

- | | |
|---|-----------------------------------|
| 1. END CONNECT O-RING (1.680 IN. O.D.) | 6. END CAP O-RING (6.00 IN. O.D.) |
| 2. END CONNECTOR | 7. END CAP |
| 3. INTERCONNECTOR O-RING (1.756 IN. O.D.) | 8. WASHER |
| 4. R.O. ELEMENT | 9. NUT |
| 5. MEMBRANE INTERCONNECTOR | 10. R.O. VESSEL |
| | 11. BRINE SEALS |

FIGURE 3-5. R.O. VESSEL (EXPLODED VIEW)

WARNING

Some R. O. elements are packaged in sealed plastic bags with the protective chemical formaldehyde, which is poisonous; avoid fumes and keep away from eyes and mouth. Handle with extreme care. After handling, wash hands thoroughly with soap and water.

CAUTIONS

- After removing R.O. element from sealed bag, take care to keep element clean. Failure to do so will bring dust and dirt into R.O. elements and cause early element failure.
- Do not expose elements to direct sunlight for an extended period of time. Sunlight may damage the elements.

(3) Remove new R.O. element (4) from sealed plastic bag or element container.

(4) Refer now to figure 3-6, and install brine seal (1) in groove of R.O. element (2) making sure open end faces R.O. pump end of ROWPU.

NOTE

MC and AF Models top and second from bottom vessels have reverse flow direction. Open end of brine seal should face opposite the direction of flow.

(5) Insert by hand the first R.O. element (2) into R.O. vessel (3) until brine seal (1) touches end of R.O. vessel.

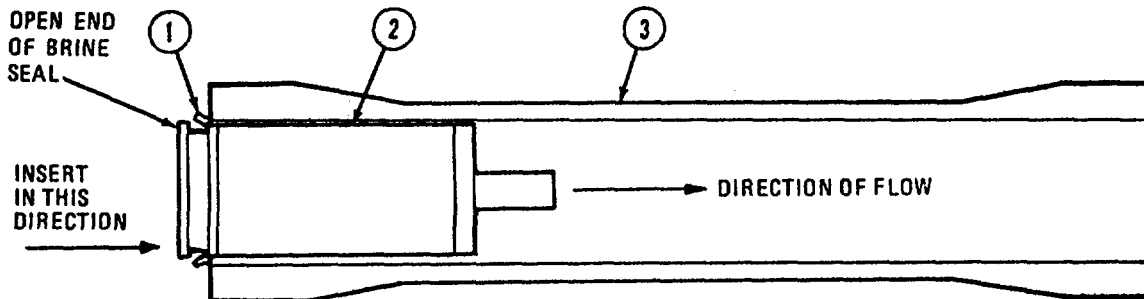

LEGEND

- 1. BRINE SEAL
- 2. R.O. ELEMENT
- 3. R.O. VESSEL

NOTE

(MC) Direction of flow is indicated on the side of each R.O. vessel

FIGURE 3-6. ELEMENT INSTALLATION

(6) Refer now to figure 3-7. Place interconnector (1) on product water tube (2) of first R.O. element (3).

NOTE

Do not confuse interconnector with end connectors. End connectors have a lip on the inside.

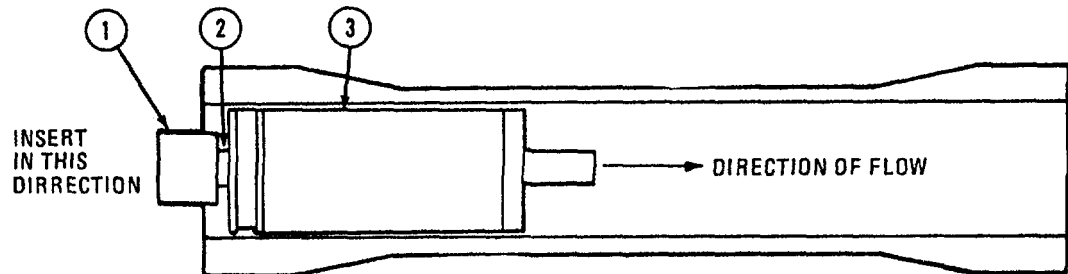

LEGEND:

- 1. INTERCONNECTOR
- 2. PRODUCT WATER TUBE
- 3. R.O. ELEMENT

FIGURE 3-7. ELEMENT INSTALLATION

(7) Remove second R.O. element from sealed plastic bag.

(8) Install brine seal (1) into groove of second R.O. element. Make sure that the open end of the brine seal is opposite the direction of flow.

(9) Refer now to figure 3-8. Insert product water tube (2) of the second R.O. element into interconnector (3).

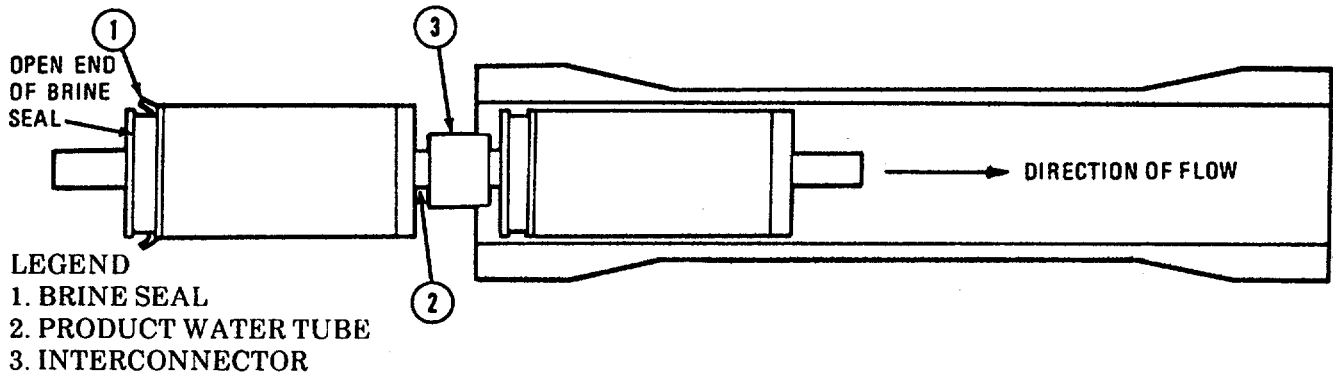
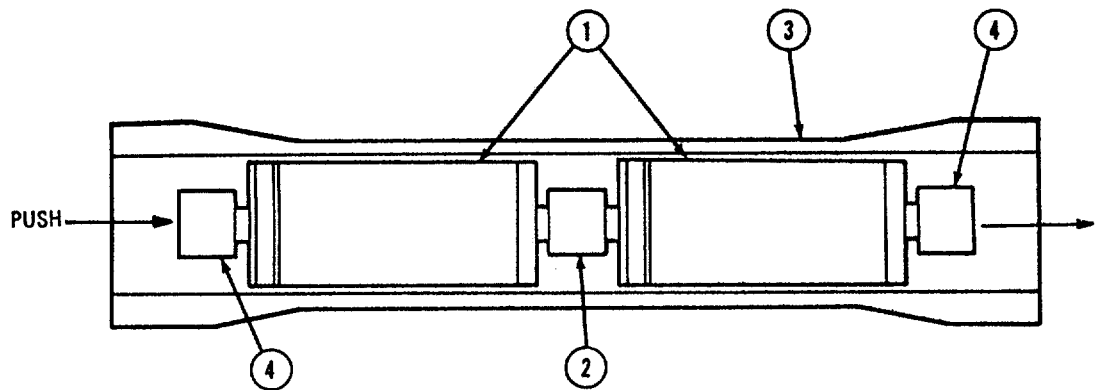

FIGURE 3-8. ELEMENT REPLACEMENT

(10) Refer now to figure 3-9. Slide both R.O. elements (1) and interconnector (2) into R.O. vessel (3) until they are centered in the vessel.

(11) Place end connectors (4) on both ends of product water tubes of R.O. elements. Join them to product water tubes of end caps.



LEGEND:
1. R.O. ELEMENTS
2. INTERCONNECTOR
3. R.O. VESSEL
4. END CONNECTOR

FIGURE 3-9. ELEMENT REPLACEMENT

- (12) Align end caps with matchmark on R.O. vessel (figure 3-1).
- (13) Press end caps onto studs.
- (14) Place 10 washers and nuts onto studs.
- (15) Slowly and evenly tighten nuts until handtight (snug). Never turn one nut more than two turns at a time. Once handtightened, evenly tighten each nut 1/8 turn with wrench.
- (16) Reconnect pipes to R.O. vessel.
 - (a) Place gasket (6) back on pipe.
 - (b) Swing elbow (7) back into place and put onto gasket (6).
 - (c) Put clamp (5) over gasket (6).
 - (d) Put bolts (4) into clamps (5).
 - (e) Put nuts (3) on bolts (4).
 - (f) Reconnect hoses (2) with clamp (1).
- (17) Operate ROWPU (paragraph 2-9) and observe for leaks.

3-5. CHANGING CARTRIDGE FILTER TUBE ELEMENTS (Refer to Figure 3-10).

a. Description . The cartridge filter contains eight filter tube elements. Cartridge filter tube elements should be changed when **CARTRIDGE FILTER** gauge differential pressure rises above 20 psid.

b. Removal.

- (1) Shut down ROWPU in the normal manner (see paragraph 2-14).
- (2) Open VENT CARTRIDGE FILTER valve (figure 2-56).
- (3) Open DRAIN NO. 1 CARTRIDGE FILTER valve (figure 2-62).

NOTE

Cover is installed under spring tension. Relieve tension by loosening eyebolts a few turns at a time in an alternating pattern.

(4) Loosen six eyebolts (4, figure 3-10). Disengage eyebolts (4) from the cover brackets (7) by swinging down.

(5) Disconnect hose from vent (8) on filter cover (1). Lift off cover with attached parts (1). Inspect O-ring (3) for cracks, breaks and hardening. Replace O-ring if damaged.

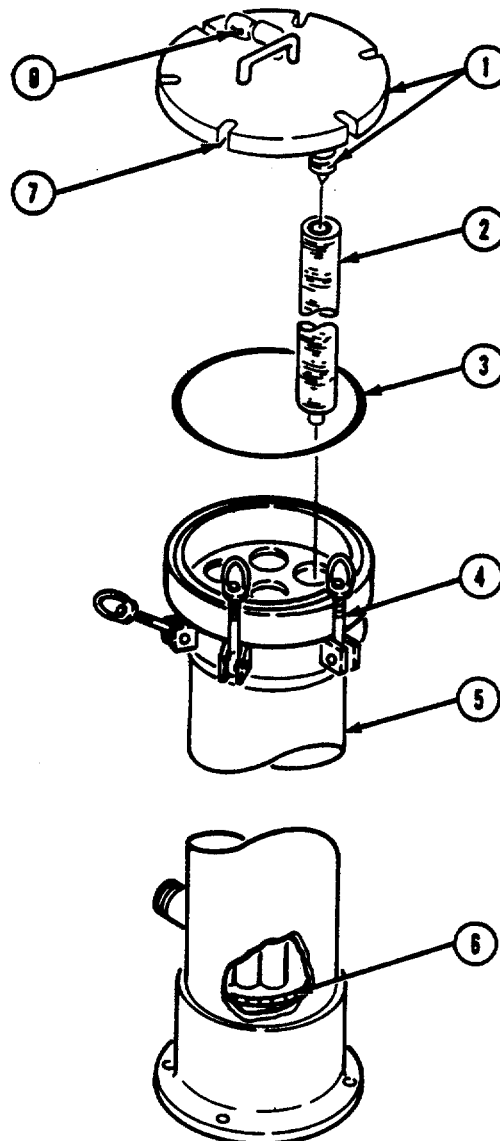

LEGEND:

1. FILTER COVER
2. FILTER TUBE
3. O-RING
4. EYEBOLTS
5. FILTER SHELL
6. BOTTOM CARTRIDGE SEAT
7. BRACKET
8. VENT

FIGURE 3-10. CARTRIDGE FILTER ASSEMBLY

- (6) Remove the eight filter tubes (2) from shell (5) and discard.

c. Installation.

- (1) Install eight new filter tubes (2) making sure that the tubes seat in the bottom cartridge seats (6).
- (2) Lubricate and replace O-ring (3) and filter cover (1).

CAUTION

Ensure all filter tubes are properly seated and filter cover is properly aligned before tightening eyebolts.

- (3) Slide eyebolts (4) into cover brackets (7) and tighten in the order shown in figure 3-11.
- (4) Attach quick-disconnect to vent (8).

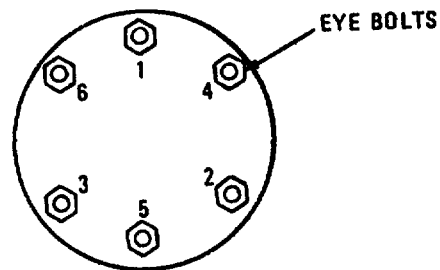

FIGURE 3-11. CARTRIDGE FILTER END PLATE (NUT TIGHTENING SEQUENCE)

3-6. BACKWASH PUMP STRAINER (Refer to Figure3-12).

a. Removal.

- (1) Shut power off to backwash pump circuit breaker CB2 (figure 2-4).
- (2) Loosen T-handle screw assembly (1) by turning to the left (counterclockwise) to release pressure on the strainer cap (4).
- (3) Swing the yoke (3) from under bolts (2) and the T-handle out of the way as shown.
- (4) Using the two ears on the strainer cap (4) twist back and forth until it loosens and lifts off the strainer housing (8).
- (5) Remove the gasket (5) and discard if it is damaged or unserviceable.
- (6) Lift handle on strainer screen (6) and remove screen from the strainer housing (8).
- (7) Remove drain plug (7) from the bottom of strainer housing (8).

b. Cleaning.

- (1) Flush strainer housing (8) with product water to remove foreign matter and dirt.
- (2) Flush strainer screen (6) with product water. Make sure that all the holes in the screen are open.
- (3) Remove dirt or corrosion from cap (4) and strainer housing (8).

c. Installation.

- (1) Install drain plug (7) in bottom of strainer housing (8).
- (2) Install the strainer screen (6).
- (3) Install the gasket (5) and strainer cap (4) on top of the strainer housing (8).

LEGEND:

- | | |
|-----------------|---------------------|
| 1. T-HANDLE | 5. GASKET |
| 2. BOLTS | 6. TRAINER SCREEN |
| 3. YOKE | 7. DRAIN PLUG |
| 4. STRAINER CAP | 8. STRAINER HOUSING |

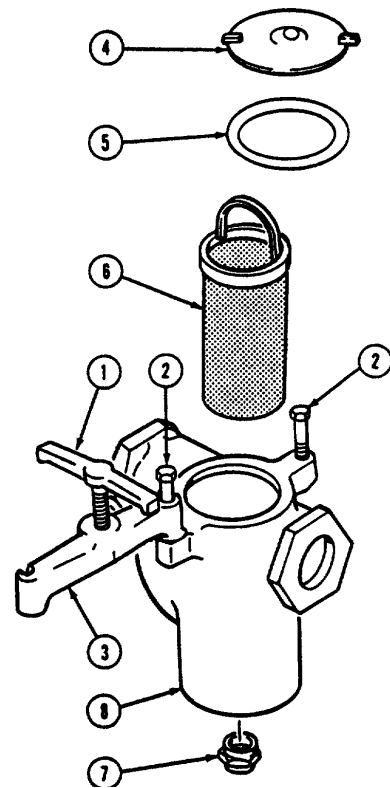

FIGURE 3-12. BACKWASH PUMP STRAINER

- (4) Swing yoke (3) and T-handle (1) back into position under the bolts (2).
- (5) Recenter the strainer cap (4) making sure the gasket is positioned correctly.
- (6) Tighten T-handle (1).

3-7. RUPTURE DISC.

CAUTION

Continued operation after the rupture disc opens could damage the ROWPU. Immediately shut off the ROWPU with the EMERGENCY STOP button (figure 2-48) and open the REGULATE PRODUCT FLOW valve (3, figure 2-64) all the way.

a. General. The rupture disc is a safety device for the R.O. Pump Assembly. If the pressure ever reaches 1425 psi on the R.O. pressure PSI gage, the rupture disc tears open relieving the pressure. The disc is mounted in a screw-type mount body on top of the R.O. pump discharge pipe. Replace the rupture disc after it blows, and before starting the ROWPU again.

b. Removal.

- (1) Remove holddown screw (1) from body (4).
- (2) Remove holddown ring (2).
- (3) Remove ruptured disc (3) and discard.

LEGEND:
1. HOLDDOWN SCREW
2. HOLDDOWN RING
3. RUPTURE DISC
4. BODY

c. Installation.

- (1) Place the side of new rupture disc (3) that curves upward at the top.
- (2) Insert it into body (4).
- (3) Replace holddown ring (2).

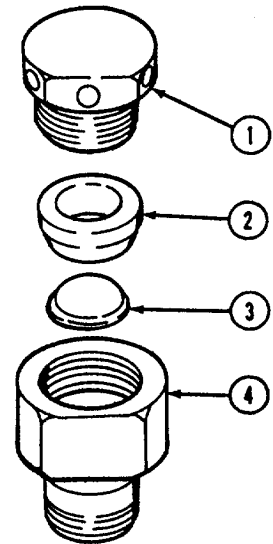

FIGURE 3-13. R.O. PUMP RUPTURE DISK AND HOLDER

CAUTION

To avoid damaging disc, do NOT overtighten holddown screw.

- (4) Reinsert holddown screw (1). Tighten until handtight (snug), then tighten 1/8 turn with wrench.

3-8. CALIBRATION AND REPAIR OF TDS METER (PORTABLE).

CAUTION

The TDS meter is an accurate meter. With the exception of calibrating meter or replacing meter battery, never attempt to service or modify instrument, nor allow it to get wet since moisture will damage the meter.

a. Calibration. Each time before using TDS meter, perform a calibration check in accordance with paragraph 2-15c(4). Whenever switching to or from seawater sources, meter must be recalibrated in accordance with paragraph 2-15c(2) or paragraph 2-15c(3).

b. Battery Replacement (figure 3-14):

- (1) Remove bottom plate.
- (2) Disconnect leads from battery.
- (3) Install new battery and connect leads.
- (4) Install bottom plate.
- (5) Depress indicator button and adjust wheel until the dial reading is equal to the value stamped on the bottom plate. If using a seawater source, refer to paragraph 2-15c.
- (6) If reading cannot be adjusted after replacing battery, replace the TDS meter.

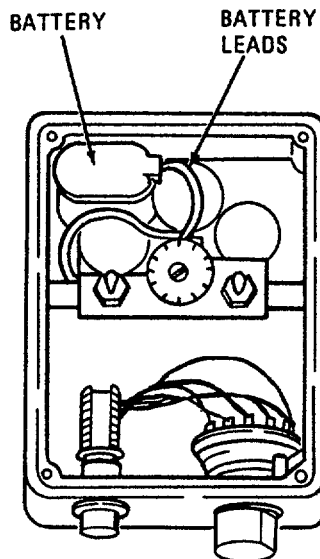

FIGURE 3-14. TOTAL DISSOLVED SOLIDS (TDS) METER BATTERY REPLACEMENT

3-9. REPLACE SWITCH INDICATOR LAMPS (Refer to Figure 3-15).

a. Removal.

- (1) Unscrew lens cap (1).
- (2) Twist bulb (2) to left and push in at the same time using lamp puller in Storage Box No. 2.

CAUTION

Be careful not to lose the cupped gasket washer. Without this gasket, you can break lens when tightening, and dampness will fog lens.

LEGEND:

1. LENS CAP
2. LAMP BULB
3. GASKET WASHIER
4. LAMP BASE HOLDER

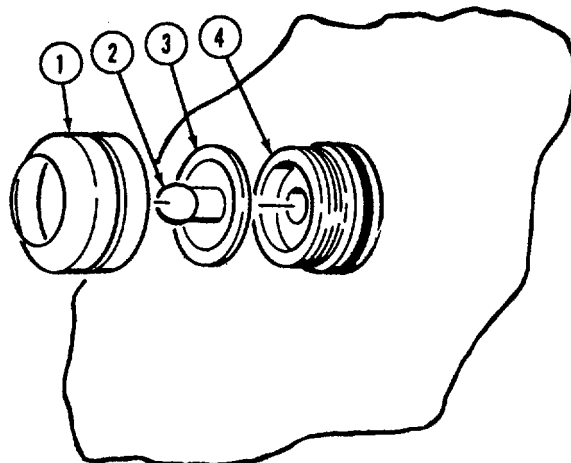

FIGURE 3-15. SWITCH INDICATOR LAMP REPLACEMENT

b. Installation.

- (1) Replace bulb (2) with lamp puller in Storage Box No. 2.
- (2) Cover the lamp base holder (4) with gasket washer (3).

NOTE

Clean lens cap (1) before reassembly.

- (3) Screw on lens cap (1).

3-10. REPLACING LAMP IN THE PANEL LIGHT (Refer to Figure 3-16).

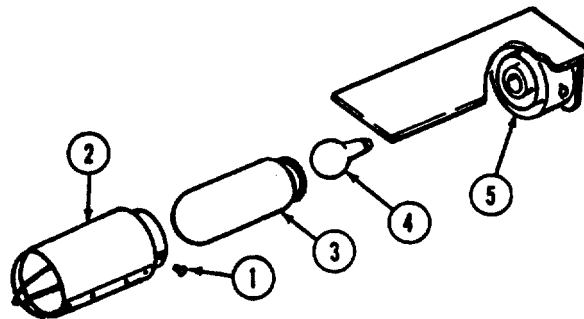

LEGEND:

1. SETSCREW
2. GUARD
3. LENS
4. BULB
5. LAMP BASE

FIGURE 3-16. PANEL LAMP REPLACEMENT

a. Removal.

- (1) Using flat-tip screwdriver, loosen setscrew (1), observing position of shield.
- (2) With your fingers, unscrew guard (2), lens (3), and bulb (4) from lamp base (5).

NOTE

Lens must be cleaned before installation.

b. Installation.

- (1) With yor fingers, screw bulb (4), lens (3), and guard (2) into lamp base (5).
- (2) Position shield in same position it was in before you removed it.
- (3) Using flat-tip screwdriver, tighten setscrew (1) to secure guard.

3-11. REPLACING TOTAL DISSOLVED SOLIDS (TDS) METER. (Refer to figure 3-17).

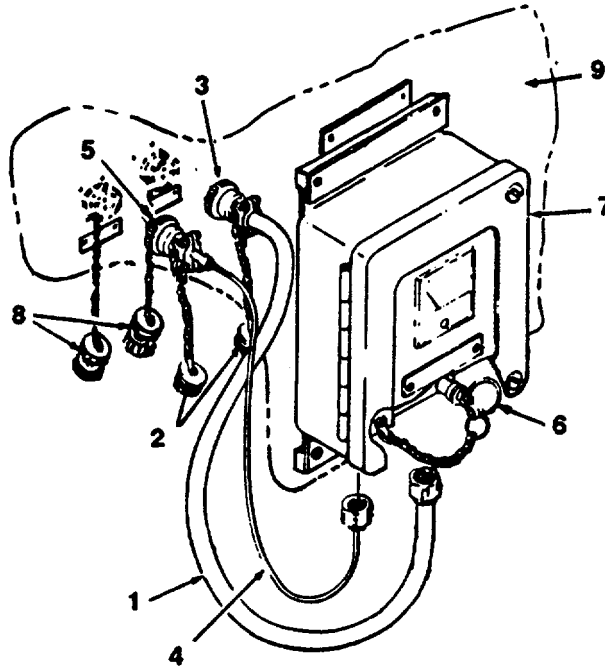

FIGURE 3-17. TOTAL DISSOLVED SOLIDS (TDS) METER

a. Removal.

- (1) Disconnect cable (1) from terminal marked TDS MONITOR POWER and attach protective cover (2) to connector (3).
- (2) Disconnect cable (4) from terminal marked TDS MONITOR SENSOR and attach protective cover (2) to connector (5).
- (3) Remove pin (6) from bottom of panel face and slide meter (7) to right until bottom of meter clears bottom of bracket.
- (4) Lift meter (7) from panel face.
- (5) Attach protective covers (8) to two terminal connectors.
- (6) Install pin (6) to panel face.

b. Installation.

(1) Remove pin (6) from panel face.

(2) Position top of meter (7) inside of upper bracket on panel face.

(3) Slide meter (7) to left and engage bottom of meter in slot of lower bracket.

(4) Continue to slide meter (7) to left until meter is fully engaged. Secure meter by positioning pin (6) through hole in bottom of meter and hole in panel face.

(5) Remove protective cover (8) from terminal marked TDS MONITOR POWER and TDS MONITOR SENSOR located on panel face.

(6) Remove protective covers (2) from cable (1) and attach connector (3) to terminal marked TDS MONITOR POWER.

(7) Remove protective covers (2) from cable (4) and attach connector (5) to terminal marked TDS MONITOR SENSOR.

CHAPTER 4

MAINTENANCE OF AUXILIARY EQUIPMENT

4-1. POWER SOURCE. (ARMY)

Maintenance of Army generator set is covered in TM 5-6115-465-12 for NSN 6115-00-118-1240.

Maintenance of 3,000 gallon water tank is covered in TM 5-5430-227-12&P.

(MC) Marine Corps and (AF) users will refer to applicable publications referencing power sources used by that organization.

4-1/(4-2 blank)

APPENDIX A
REFERENCES

A-1. SCOPE.

This appendix lists all forms, field manuals, and technical manuals, referenced in this manual.

A-2. FORMS.

Consolidated Engineer Equipment Operation Log and Service Record.....	NAVMC 10524
Equipment Daily or Monthly Log	DA Form 2408-1
Equipment Inspection and Maintenance Work Sheet	DA Form 2404
Maintenance Data Collection Record	AFTO Form 349
Maintenance Request	DA Form 2407
Quality Deficiency Report	SF 368
Recommended Changes to DA Publications	DA Form 2028-2
Recommended Changes to Technical Publications	NAVMC 10772
Technical Orders System	
Publication Improvement Report and Reply	AFTO Form 22

A-3. TECHNICAL MANUALS.

Equipment Record Procedures	TM 4700-15/1
Hand Receipt Covering End Item/Components of End Item (COEI), Basic Issue Items (BII), and Additional Authorization List Items (AAL) for Water Purification Unit, Reverse Osmosis	TM 10-4610-240-10-HR
Operator and Organizational Maintenance Manual; Generator Set, Diesel Driven, Tactical Skid Mtd. 30 KW, 3 Phase, 4 Wire, 120/208 and 240/416 Volts, NSN 6115-00-118-1240 (ARMY)	TM 5-6115- 465-12
Operation and Maintenance Manual; 3,000 Gallon Self-Supporting Water Tank	TM 5-5430-227-12&P

A-4. MISCELLANEOUS.

The Army Maintenance Management Systems (TAMMS)	DA PAM 738-750
Department of the Army Information Security Program	AR 380-5
Department of Navy Information and Personnel Security Program Regulations	OPNAVINST 5510.1
Lubricating Order.....	LO 10-4610-240-12
	LI 8580C-12
	TO 40W4-13-31
Identification and Distribution of Department of the Army Publications and Issue of Agency and Command Administrative Publications	AR 310-2
First Aid Manual	FM 21-11
Marine Corps Military Incentive Awards Program	MCO 1650-17
Stock Lists for ROWPU (MC)	SL 3-08580A
Supply Catalog	SC 4610-97-CL-E16

APPENDIX B

COMPONENTS OF END ITEM AND BASIC ISSUE ITEMS LIST

Section I. INTRODUCTION

B-1. SCOPE

This appendix lists components of end item and basic issue items for the ROWPU to help you inventory items required for safe and efficient operation.

B-2. GENERAL

The Components of End Item and Basic Issue Items List are divided into the following sections:

a. Section II. Components of End Item. This listing is for informational purposes only, and is not authority to requisition replacements. These items are part of the end item, but are removed separately packaged for transportation or shipment. As part of the end item, these items must be with the end item whenever it is issued or transferred between property accounts. Illustrations are furnished to assist you in identifying the items.

b. Section III. Basic Issue Items. These are the minimum essential items required to place the ROWPU in operation, to operate it, and to perform emergency repairs. Although shipped separately packaged, BII must be with the ROWPU during operation and whenever it is transferred between property accounts. The illustrations will assist you with hard-to-identify items. This manual is your authority to request/requisition replacement BII, based on TOE/MTOE authorization of the end item.

B-3. EXPLANATION OF COLUMNS

The following provides an explanation of columns found in the tabular listing:

a. Column (1) - Illustration Number (Illus Number). This column indicates the number of the illustration in which the item is shown.

b. Column (2) - National Stock Number. Indicates the national stock number assigned to the item and will be used for requisitioning purposes.

c. Column (3) - Description. Indicates the Federal item and name and, if required, a minimum description to identify and locate the item. The last line for each item indicates the FSCM (in parentheses) followed by the part number.

d. Column (4) - Unit of Measure (U/M). Indicates the measure used in performing the actual operational/maintenance function. This measure is expressed by a two-character alphabetical abbreviation (e.g., ea, in, pr).

e. Column (5) - Quantity required (Qty reqd). Indicates the quantity of the item authorized to be used with/on the equipment.

Section II. COMPONENTS OF END ITEM LIST

(1) Illus Number	(2) National Stock Number	(3) Description FSCM and Part Number	(4) Usable On Code U/M	(5) Qty Rqr
1	4730-01-267-0001	Adapter Assembly, Female NPSH to Female Cam-Lock (97403) 13227E8836	EA	1
2	4730-00-088-9285	Adapter, Cam-Lock; 2-Inch, Female to 2 Inch NPT External Thread MS27026-11	EA	2
3	4210-01-131-8245	Reducer, Hose: cop aly; NPSH 1st/2nd end; 1.500 in. lg; (30659) 369R-1 1/2NPSH x 2NPSH	EA	2
4	4730-01-230-6584	Adapter, Straight, Pipe to Hose: cop aly: 0.500 in NPTF ext pipe 1st end; 0.750 in. id hose 2nd end; 1.860 in. lg; (This item was initially issued by (97403) P/N 13228E3312-14); (97403) 13218E7108-15	EA	4
5	4730-01-331-2848	Adapter, Straight, Pipe to Hose: cop aly; 0.750 in. NPT ext pipe 1st end; 0.750 in. id hose 2nd end; 1.880 in. lg; This item was initially issued by (97403) P/N 13228E3312-16); (93061) 125HBL-12-12	EA	2
6	4730-00-278-8271	Adapter, Straight, Pipe to Hose: Brass Pipe End 1-1/2 Inch - 11-1/2 NPT External; Hose End 1-1/2 Inch - 11-1/2 NPSH Internal; (81349) MIL-C-52404, Type XVI, Class B	EA	2
7	4730-00-277-6844	Adapter, Straight, Pipe to Hose: Brass; Pipe End 1-1/2 Inch - 11-1/2 NPT External; Hose End 1-1/2 NPSH External (81349) MIL-C-52404, Type XVI Class C	EA	1
8	4730-00-277-6845	Adapter, Straight, Pipe to Hose: Brass; Pipe End 2 Inch - 11-1/2 NPT External; Hose End 2 Inch - 11-1/2 NPSH External (81349) MIL-C-52404, Type XVI, Class C	EA	1
9	4730-01-088-1698	Adapter, Swivel, Hose Brass; 2 Inch - 11-1/2 NPSH External One End; 1-1/2 Inch - 11-1/2 NPSH Internal Swivel Other End (97403) 13221E8277	EA	1

Section II. COMPONENTS OF END ITEM LIST

(1) Illus Number	(2) National Stock Number	(3) Description FSCM and Part Number	Usable On Code	(4) U/M	(5) Qty Rqr
10	4730-01-107-7630	Adapter, Swivel, Pipe to Hose: Brass; Pipe End 2 Inch - 11-1/2 NPT External; Hose End 2 Inch - 11-1/2 NPSH Internal (97403) 13221E8290-2		EA	1
11	4730-00-277-1873	Bushing, Pipe: Shoulder (96906) MS14315-20Y		EA	2
12	4730-01-353-2984	Coupling, Cam-Lock; 2 Inch Male to 2 Inch NPSH Internal Thread MS70095-4		EA	4
13	4730-01-353-0585	Coupling Half, Quick Disconnect: al-aly; 150 psi oper press; thd ent str thd type 16, 2 in. NPSH 1st end; cam-locking, female, 2 in. other end; (96909) MS70096-4		EA	4
14	4730-00-432-7448	Coupling, Cam-Lock; 2 Inch Male to 1-1/2 Inch NPT External Thread MS49001-9		EA	2
15	7240-01-223-3439	Can Assembly, Chemical Feed, Chlorine: (97403) 13226E7990-4		EA	1
16	7240-01-224-2852	Can Assembly, Chemical Feed, Citric Acid: (97403) 13226E7990-3		EA	1
17	7240-01-223-3438	Can Assembly, Chemical Feed, Polymer: (97403) 13226E7990-1		EA	1
18	7240-01-223-3437	Can Assembly, Chemical Feed, Sodium Hex: (97403) 13226E7990-2		EA	1
19	4610-01-128-1844	Cartridge, Chemical Agent Removal; (97403) 13221E8341-2		EA	1
20	4610-01-116-0501	Cartridge, Radiological Contaminant Removal; No. D9001 (05852); (97403) 13221E8341-1		EA	1
21	5140-01-223-3440	Chest Assembly, (97403) 13221E8380-1		EA	1
22	5140-01-223-3441	Chest Assembly, (97403) 13221E8380-2		EA	1

Section II. COMPONENTS OF END ITEM LIST

(1) Illus Number	(2) National Stock Number	(3) Description FSCM and Part Number	(4) Usable On Code U/M	(5) Qty Rqr
23	4730-00-908-3194	Clamp, Hose; Low Pressure, Type "F", (96406) MS35842-11 (96406)	EA	6
24	4730-01-125-4456	Coupling, Pipe: Corrosion Resistant: (97403) 13218E0439-8	EA	1
25	4610-01-105-2075	Element, Reverse Osmosis, Spiral Wound (97403) 13226E2212	EA	8
26	4820-00-066-2478	Float, Valve: al aly; cyl; 10 in. oa dia, 27 in. oa lg. 0.750 in. dp, 0.500 in. thk; (07954) 9576-53-1	EA	1
27	6115-00-118-1240	Generator Set, Diesel Engine Driven Tactical, Utility, Skid Mtd, 30 kW, 3 phase, 4 Wire, 120/208 and 240/416 Volts, 50/60 Hertz (81349) MIL-G-52884/5	EA	1
28	4720-00-289-6123	Hose Assembly, Cotton, Rubber Lined: Single Jacket; Synthetic; 300 psi Test Pressure; Brass Coupling Each End, FED Spec WW-C-621, Type B1, Expansion Ring, Rocker Lug, Rigid External THD One End and Swivel Internal THD Other End; 1-1/2 Inch - 11-1/2 NPSH: 1-1/2 in ID: 25 Ft. Lg, Excluding Couplings; ZZ-H-45 1, Type I, Class B, Size 1-1/2	EA	6
29	4720-01-136-6564	Hose Assembly, Polyester, Rubber Lined: Single Jacket; Synthetic; 350 psi Test Pressure; Brass Coupling Each End, FED Spec WW-C-621, Type B1, Expansion Ring, Rocker Lug, Rigid External THD One End and Swivel Internal THD Other End; 2 Inch - 11-1/2 NPSH: 1 Inch ID; 25 Ft. L, Excluding Couplings; ZZ-H-451, Type m, Class B. Size 2,	EA	3
30	4720-01-136-0092	Hose Assembly, Rubber, Smooth Bore, Suction and Discharge, Wrapped Fabric Construction, Wire Reinforcement, 100 psi Test Pressure, Brass Coupling Each End, WW-C-624, Type B1, Expansion Ring. Rocker Lug, Rigid External THD One End and Swivel Internal Thd Other End; 2 Inch - 11-1/2 NPSH, 2 Inch ID: 10 Ft. Long Excluding Coupling; ZZ-H-561, Grade B, Style A, Class 1, Size 2.	EA	3

Section II. COMPONENTS OF END ITEM LIST

(1) Illus Number	(2) National Stock Number	(3) Description FSCM and Part Number	(4) Usable On Code U/M	(5) Qty Rqr
31	4720-00-202-6731	Hose Assembly, Rubber, Smooth Bore Suction and Discharge, Wrapped Fabric Construction, Wire Reinforcement, 100 psi Test Pressure, Brass Coupling Each End, WW-C-024, Type B1, Expansion Ring, Rocker Lug, Rigid External THD One End and Swivel Internal THD Other End; 1-1/2 Inch - 11-1/2 NPSH, 1-1/2 Inch ID; 10 Ft. Long Excluding Couplings; ZZ-H-561, Grade B, Style A, Class 2, Size 1-1/2.	EA	9
32	6630-01-346-7271	Meter, Salinity Indicating, Electric: panel instl; nonmagnetic; (97403) 13227E7385	EA	1
33	2910-01-188-8198	Nozzle, Water Distribution: 1.500 NPT intl thd; rgd spout, w/reducing bushing and dust cap; (This item was initially issued under 4930-00-902-4642); (81718) DC-190-GW-1-1/2	EA	1
34	4320-01-083-9863	Pump Assembly, Backwash (97403) 13222E5260	EA	1
35	4320-01-083-9859	Pump Assembly, Distribution (97403) 13222E5265	EA	1
36	4320-01-084-2235	Pump Assembly, Raw Water (97403) 13222E5250	EA	2
37	7125-01-232-7686	Rack, Chemical Feed Can (97403) 13226E8331	EA	1
38	4730-01-133-1727	Reducer, Adapter; 1/2 NPT External X 3/4 Hose Internal (81343) J530	EA	2
39	4210-00-377-6521	Reducer, Hose; 2 Inch NPSH Internal Thread to 1-1/2 Inch NPSH Internal Thread MIL-C-52404, Type 15, Class A	EA	2
40	5975-01-053-3991	Rod, Ground: Three 3-Ft Sections; w/attachments; W-R-550, Type m, Class B	EA	1
41	2540-01-115-1513	Step, Portable, (97403) 13221E8342	EA	1

Section II. COMPONENTS OF END ITEM LIST

(1) Illus Number	(2) National Stock Number	(3) Description FSCM and Part Number	(4) Usable On Code U/M	(5) Qty Rqr
42	4730-00-684-4296	Strainer, Suction Hose: Brass; Cylindrical, (13228) 13228E8307	EA	1
43	5430-01-170-6984	Tank, Assy Fabric, Collapsible: Water Sto (81349) MIL-T-14398	EA	3
44	2330-01-226-0709	Trailer, Flatbed: 600 GPH ROWPU (97403) 13222E7100	EA	1
45	4720-01-132-0800	Tubing, Flexible, Reinforced; 80.00 Inch Lg (97403) 13221E8367-2	EA	3
46	4820-00-288-7568	Valve, Gate 1-1/2 Inch - 11-1/2 NPT (81348) WWV-54	EA	1
47	4820-00-595-1847	Valve, Gate 2 Inch - 11-1/2 NPT (81348) WWV-54	EA	1
48	4610-01-300-0918	Water Purification Unit, Skid Mtd, TY II, (81349) MIL-W-52960	EA	1
49	4610-01-295-2719	Water Purification Unit, Skid Mounted Type mll: (81349) MIL-W-52960	EA	1
50	4610-01-295-2720	Water Purification Unit, Trailer Mtd, TY I: Reverse Osmosis, 600 GPH, (81349) MIL-W-52960	EA	1

Section II. COMPONENTS OF END ITEM

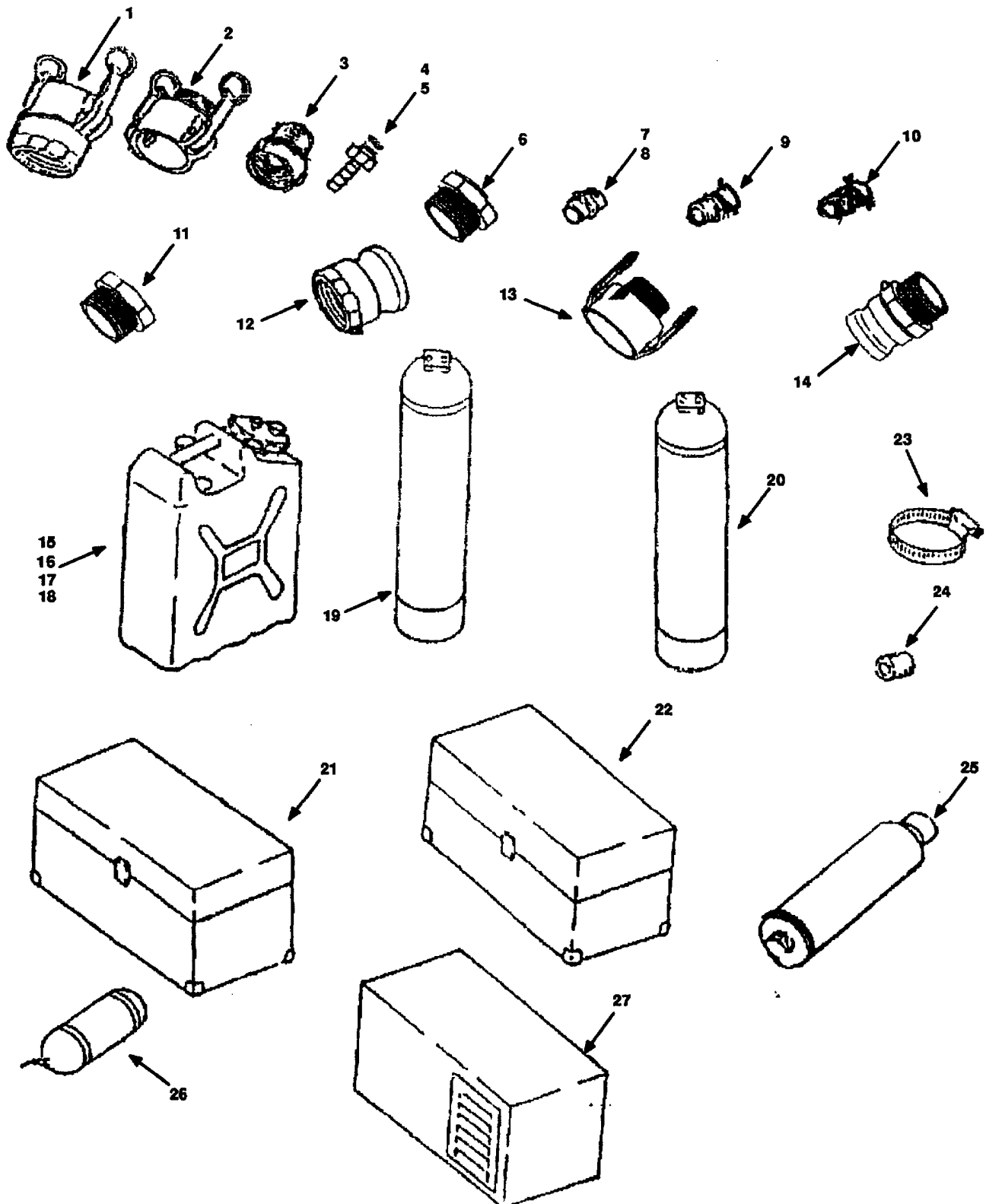

Section II. COMPONENTS OF END ITEM

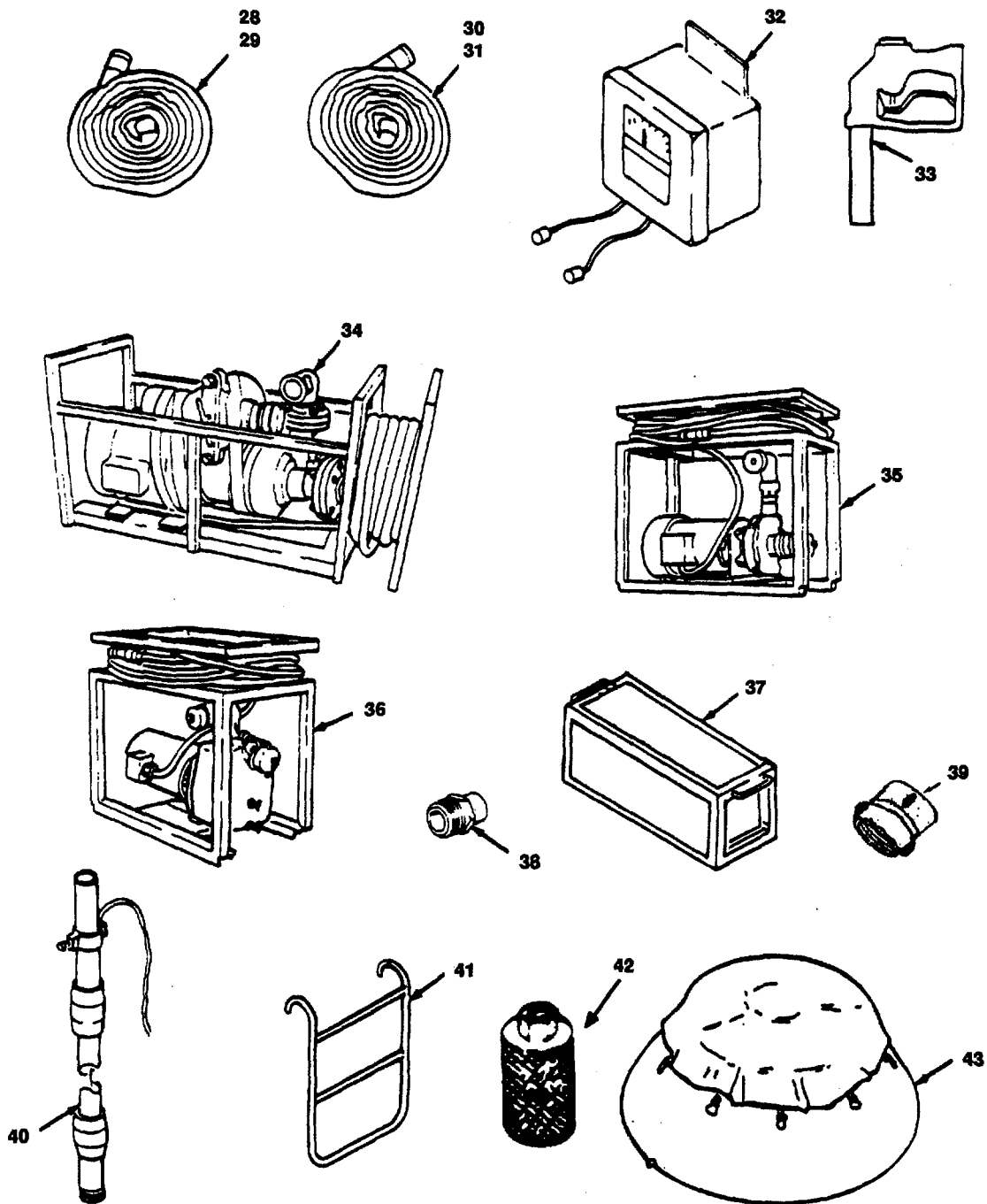

Section II. COMPONENTS OF END ITEM

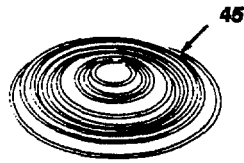
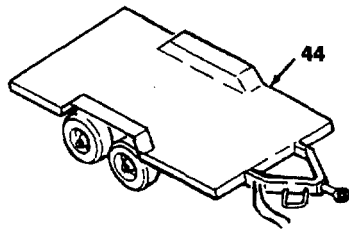

END ITEM

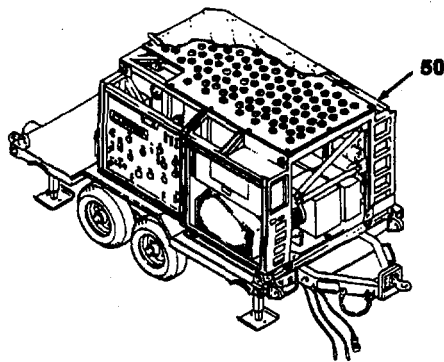
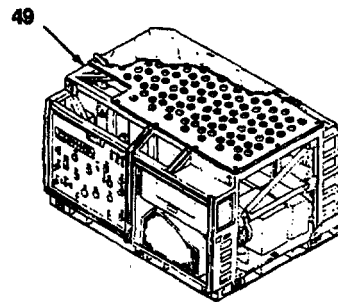
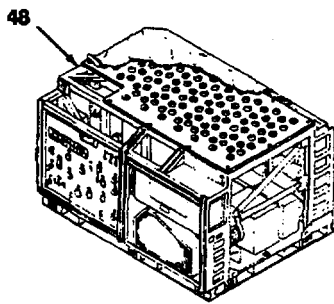

LOADING PLAN STORAGE BOX-ACCESSORIES

COMPARTMENTS

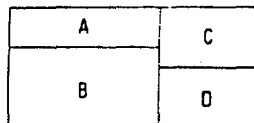

TRAYS



QTY	UNIT	ARTICLE	COMP
1	EA	METER, DISSOLVED SOLIDS	D
9	EA	INDICATOR LAMPS, 6-8-6	F
1	EA	EXTRACTOR, LAMP	D
1	EA	EXTENSION LIGHT, 50 FT CORD	B
1	EA	BULB, INCANDESCENT, 100 W	F
1	EA	THERMOMETER, 0-220° F	F
1	EA	STRAINER, SUCTION HOSE	A
3	EA	GRADUATED BEAKER, 250 ML	D
1	ROLL	TAPE, ANTI-SEIZE	D
1	EA	MEASURE, SODIUM HEX, 0.1 LB	F
1	EA	MEASURE, POLYELECTROLYTE, 107 ML	F
1	EA	MEASURE, CAL. HYPOCHLORITE, 0.06 LB	F
1	EA	FLASHLIGHT	F
1	EA	HANDLE, SOCKET WRENCH, RACHET	B
1	EA	ADAPTER, 2NPT EXT X 2 NPSH EXT	C
1	EA	TOOL CASE WITH CONTENTS:	E
1	EA	SCREWDRIVER, 2 PHILLIPS	E
1	EA	SCREWDRIVER, 6"	E
1	EA	SCREWDRIVER, STUBBY	E
1	EA	PLIERS, 6"	E
1	EA	WRENCH, PLIER	E
1	EA	WRENCH, ADJUSTABLE, 6"	E
1	EA	WRENCH, ADJUSTABLE, 12"	E
2	EA	WRENCH, PIPE, ALUMINUM, 18"	E
1	EA	BALL PEEN HAMMER 240Z	E
1	EA	SPANNER WRENCH, UNIV. HOSE	E
1	EA	TOOL, PACKING ADJUSTMENT	E
1	EA	KEY, WRENCH, SOCKET HEADSCREW, 5MM	E
1	EA	ADAPTER, SWIVEL, 2 NPSH EXT X 1-1/2 NPSH INT	C
2	EA	ADAPTER, 1-1/2 NPT EXT X 1-1/2 NPSH INT	C
2	EA	ADAPTER, 1-1/2 NPSH EXT X 2 NPSH INT	C
1	BOX	BATTERY, 9 VOLT, 2 TERMINALS	F
1	EA	NOZZLE, PISTOL-GRIP, 1-1/2 NPT	B
1	EA	VALVE, GATE, 1-1/2 NPT	B
1	EA	ROPE, MANILA, 1/2 IN X 36"L	B
1	EA	VALVE, GATE, 2-11/2 NPT	C
1	EA	CASE, MAINTENANCE AND OPERATIONAL MAN	A
1	EA	ADAPTER, SWIVEL, 2 NPT EXT X 2 NPSH INT	C
1	EA	ADAPTER, STRAIGHT, 1-1/2 NPT EXT X 1-1/2 NPSH EXT	C
3	EA	LUBRICANT, 'O' RING	F
1	EA	ADJUSTING TOOL	B
1	EA	EXTENSION, SOCKET WRENCH	B
1	EA	HANDLE, SOCKET WRENCH, BRACE	B
1	EA	MALLET, RUBBER	B
8	EA	MACHINE SCREW, HEX HD	C
7	EA	SOCKET, WRENCH, 1/2 - 15/16	B
1	EA	WRENCH BOX AND OPEN END, 1-1/2"	E
1	SET	WRENCH SET, COMB., BOX AND OPEN END	E
1	EA	WRENCH, PIPE - STRAP	B
8	EA	PLUG, PIPE, 1/2 NPT	C
1	EA	PLUG, PIPE, 1/4 NPT	C
1	EA	3/8 HEX BAR	C
1	EA	1/2 HEX BAR	C

STORAGE BOX 2

Change 2 B-10

LOADING PLAN STORAGE BOX - ACCESSORIES

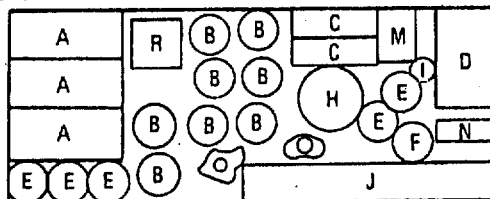

QTY	UNIT	ARTICLE	COMP
3	EA	POLYMER, '' LB EA	A
8	EA	RD ELEMENT END CONNECTION AND O-RINGS	B
2	EA	SODIUM HEX, '' LB EA	C
1	EA	COLOR COMPARATOR	D
5	EA	CITRIC ACID, ¼ LB EA	E
1	EA	SOLUTION, WIDE RANGE ph, 16-oz	H
1	EA	GRADUATED PLASTIC CYLINDER, 100ml	I
4	EA	PADDLE, WOOD	J
1	EA	TRITON X 100 MEMBRANE CLEANING SOLUTION 2 LB PLASTIC BOTTLE	M
1	EA	CHLORINE, PALIN, DPD, 100 TABLETS	N
1	EA	TURBIDITY TUBE	O
1	EA	TOOL CASE WITH CONTENTS	E
1	EA	COUPLING PIPE, CORROSION RESISTANT	P
2	EA	BUSHING PIPE SHOULDER	P
6	EA	ADAPTER, BRASS, PIPE TO HOSE	P
6	EA	CLAMP, HOSE, LOW PRESSURE	P
3	EA	TUBING, FLEXIBLE, REINF 80.00 IN LONG	Q
1	EA	TDS MONITOR	R

STORAGE BOX 3

Section III. BASIC ISSUE ITEMS

(1) Illus Number	(2) National Stock Number	(3) Description FSCM and Part Number	Usable On Code	(4) U/M	(5) Qty Rqr
1	5140-00-772-4142	Bag, Tool, Envelope Type: Cotton Duck; Size 4, 10-1/8 Inch H, 20-1/4 Inch Long, (81349) MIL-B-43648		EA	2
2	6135-00-850-3177	Battery, Dry: 9 Volt; 2 Terminals Snap-On Terminal; Rectangular Shape (81348) W-B-101		BX	1
3	6640-00-942-4393	Beaker, Laboratory: With Spout Borosilicate Glass, 250 ml, (81348) NNN-B-175		EA	3
4	7520-00-559-9618	Case, Maintenance and Operational Manuals; Cotton Duck, Mildew Resistant, Water, Repellant, 22 Inch H, 12.75 Inch Lg. (81349) MIL-C-11743		EA	1
5	6630-01-044-0334	Comparator, Color: (12308) U25337		EA	1
6	6640-01-086-7603	Cylinder, Graduated, Plastic: 100 ml (22527) No. 8-572D		EA	1
7		Discharge Valve Cover Capscrew Adapter, 1/2 Inch Hex Bar, 2 Inch Long (61748) 001		EA	1
8	4240-00-022-2946	Ear Muff-Type Hearing Protectors		EA	1
9	6515-00-137-6345	Ear Plugs, Disposable: 400 per box		BX	1
10	5120-00-243-7326	Extension, Socket Wrench: 5 Inch Long: (81348) GGG-W-641		EA	1
11	5120-00-288-7679	Extractor, Lamp		EA	1
12	4330-01-128-6277	Filter, Tube: For Cartridge Filter: (97403) 13226E2210, (80244) RD. 7FXEE-92-239YXI		EA	1
13	6230-00-264-8261	Flashlight: Type I, Style 2. (81349) MIL-F-3747		EA	1
14		Gland Adjusting Tool, 3/16 Inch Dia Rod, 8 Inch Long (61748) 003		EA	1

Section III. BASIC ISSUE ITEMS

(1) Illus Number	(2) National Stock Number	(3) Description FSCM and Part Number	(4) Usable On Code U/M	(5) Qty Rqr
15	5120-00-061-8545	Hammer. Hand: 1-1/2 lb Head Weight; Type 2, Style B, Class 1, (81348) GGG-H-86	EA	1
16	5120-00-251-4489	Hammer, Hand: 8 lb Head Weight; Double Face, Type X, Class 1, (81348) GGG-H-86	EA	1
17	5120-00-249-1071	Handle, Socket Wrench: Brace Speeder Type; 16 Inch to 20 Inch Long, (81348) GGG-W-641	EA	1
18	5120-00-230-6385	Handle, Socket Wrench: Ratchet Type Reversible; 9 Inch; (81348) GGG-W-641	EA	1
19	5120-00-900-9344	Key, Socket Head Screw: 5 mm (57719) AWM-5C	EA	1
20	6240-00-246-5022	Lamp, Incandescent: 120 Volts, 100 Watts (96906) W-L-101/77	EA	1
21	6240-00-143-3049	Lamp, Incandescent: Bulb Size S-6; 6 Watts (96906) MS 15567-2	EA	9
22	6240-00-901-9755	Light, Extension: Closed End Guard w/Hook; Plastic Body w/Switch, Lamp Accommodation Incl; 50 Ft Lg; (81348) W-L-661	EA	1
23	5120-00-293-3399	Mallet, Rubber: Barrel-Shaped, 20 Oz, Type III, Class 3, (81348) GGG-H-33	EA	1
24		Manuals, Technical Operator's Maintenance Manual, 600 GPH Reverse Osmosis Water Purification Unit, TM-10-4610-240-10 Unit, Direct and General Support Manual, 600 GPH Reverse Osmosis Water Purification Unit, TM 10-4610-240-24 Lubrication Order, LO 10-4610-240-12		

Section III. BASIC ISSUE ITEMS

(1) Illus Number	(2) National Stock Number	(3) Description FSCM and Part Number	(4) Usable On Code U/M	(5) Qty Rqr
25	4610-00-542-4639	Measure, Dry Chemical, Water Purification: Plastic. Calcium Hypochlorite; 0.05 lb Graduations; 0.20 lb; (81349) MIL-M-52379, Figure 6	EA	1
26	4610-01-115-7521	Measure, Dry Chemical, Water Purification: Sodium Hexametaphosphate; 0.1 lb; (97403) 13221E8334	EA	1
27	6640-01-168-0312	Measure, Liquid, Water Purification: Poly- electrolyte, 107 ml (97403)13221E8329	EA	1
28	6630-00-127-4774	Meter, Dissolved Solids (97403) 13222E5258	EA	1
29	7330-00-972-5211	Paddle (81349) MIL-W-52482, Fig 2	EA	4
30	4610-01-088-3233	Paddle, Aluminum (97403) 13221E8328	EA	1
31	7240-00-137-1609	Pail, Utility: Plastic or Rubber, Pouring LIP, with Bail (8134) L-P-65, Size 4	EA	4
32	5120-00-223-7396	Pliers, Slip-Joint: 6 Inch Lg; (81348) GGG-P-471, Type 2, Style A, Class 2	EA	1
33	5120-01-135-0062	Puller, Reverse Osmosis Element: (97403)13221E8330	EA	1
34		Rope, Fibrous: Manila Hemp; Type M Class 1, .75 Inch Dia (81348) T-R-605	FTr	3
35	5305-01-088-7419	Screw, Machine-Steel, Hex HD, Slotted, Carbon Steel, CAD PLTD, 1/4-20 UNC-2A, 2 Inch Lg, (96906) MS 51849-102	EA	8
36	5120-00-234-8913	Screwdriver, Cross Tip: Phillip; Plastic Handle; No. 2 Tip; 4-Inch Blade; Type VI, Class 1, Style 1 (81348) GGG-S-121	EA	1

Section III. BASIC ISSUE ITEMS

(1) Illus Number	(2) National Stock Number	(3) Description FSCM and Part Number	(4) Usable On Code U/M	(5) Qty Rqr
37	5120-00-596-8502	Screwdriver, Flat Tip: Flared Tip; Plastic Handle; 1/4 Inch Width Tip; 1 - 1/2 Inch Nom Blade Lg; (81348) GGG-S-121, Type I, Class 3	EA	1
38	5120-00-234-8910	Screwdriver, Flat Tip: Flared, Plastic Handle; 5/16-Inch Width Tip; 6-Inch Lg Blade; (81348) GGG-S- 121, Type I, Design A, Shape A	EA	1
39	5120-00-237-0984	Socket, Socket Wrench: 1/2-Inch (81348) GGG-W-641	EA	1
40	5120-00-235-5870	Socket, Socket Wrench: 11-16 Inch; (81348) GGG-W-641	EA	1
41	5120-00-189-7985	Socket, Socket Wrench: 3/4-Inch; (81348) GGG-W-641	EA	1
42	5120-00-189-7934	Socket, Socket Wrench: 7/8-Inch; (81348) GGG-W-641	EA	1
43	5120-00-189-7932	Socket, Socket Wrench: 9/16-Inch; (81348) GGG-W-641	EA	1
44	5120-00-189-7935	Socket, Socket Wrench: 15/16-Inch; (81348) GGG-W-641	EA	1
45	5120-00-189-7946	Socket; Socket Wrench: 5/8-Inch; (81348) GGG-W-641	EA	1
46		Stuffing Box Flange Capscrew Adapter, 3/8 Inch Hex Bar, 4 Inch Long (61748) 002	EA	1
47	6685-01-103-9938	Thermometer, Self-Indicating; 0-220°F; 5 Inch Stem (65092) Model 2292	EA	1
48	6630-01-105-2058	Tube, Turbidity (97403)13221E8335	EA	1
49	5120-00-148-7917	Wrench Set, Combination Box and Open End: 15 DEG Offset Box; Opening, 5/16 to 1 Inch Openings; w/Roll (81348) GGG-W-636	SET	1

Section III. BASIC ISSUE ITEMS

(1) Illus Number	(2) National Stock Number	(3) Description FSCM and Part Number	(4) Usable On Code U/M	(5) Qty Rqr
50	5120-00-264-3796	Wrench, Adjustable: Chromium Plated Open End; Single Head (81348) GGG-W-631, Type I Class 1; Size 12	EA	1
51	5120-00-264-3795	Wrench, Adjustable: Steel, Chromium Plated; Open End; Single Head (81348) GGG-W-631, Type I, Class 1, Size 6	EA	1
52	5120-00-228-9517	Wrench, Box and Open End: 1-1/2 Inch (81348) GGG-W-636	EA	1
53	5120-00-242-3249	Wrench, Pipe-Strap: 1/8" - 2" Pipe Size; (81348) GGG-651-TYI	EA	1
54	5120-00-277-1479	Wrench, Pipe: Adjustable Jaw, Stillson Pattern; Aluminum Alloy; 1 to 2 Inch IPS: 18 Inch Lg (81348) GGG-W-651. Type II, Class C	EA	2
55	5120-01-176-6931	Wrench, Plier: Straight Jaw Style: 10 Inch Nom Lg; Type 1, Class 1, Style A (81348) GGG-W-00649	EA	1
56	5120-00-293-1602	Wrench, Spanner: Universal Hose Couplings; 1-3 Inch Hose Coupling: 11 Inch Lg (81348) GGG-W-665	EA	2
57	5120-00-378-4411	Wrench, Wheel Stud Nut: 1-1/2 Inch Hex Opening One End and .812 Inch Sq Opening Other End; w/Removable Handle: (87641) 151	EA	1

Section III. BASIC ISSUE ITEMS

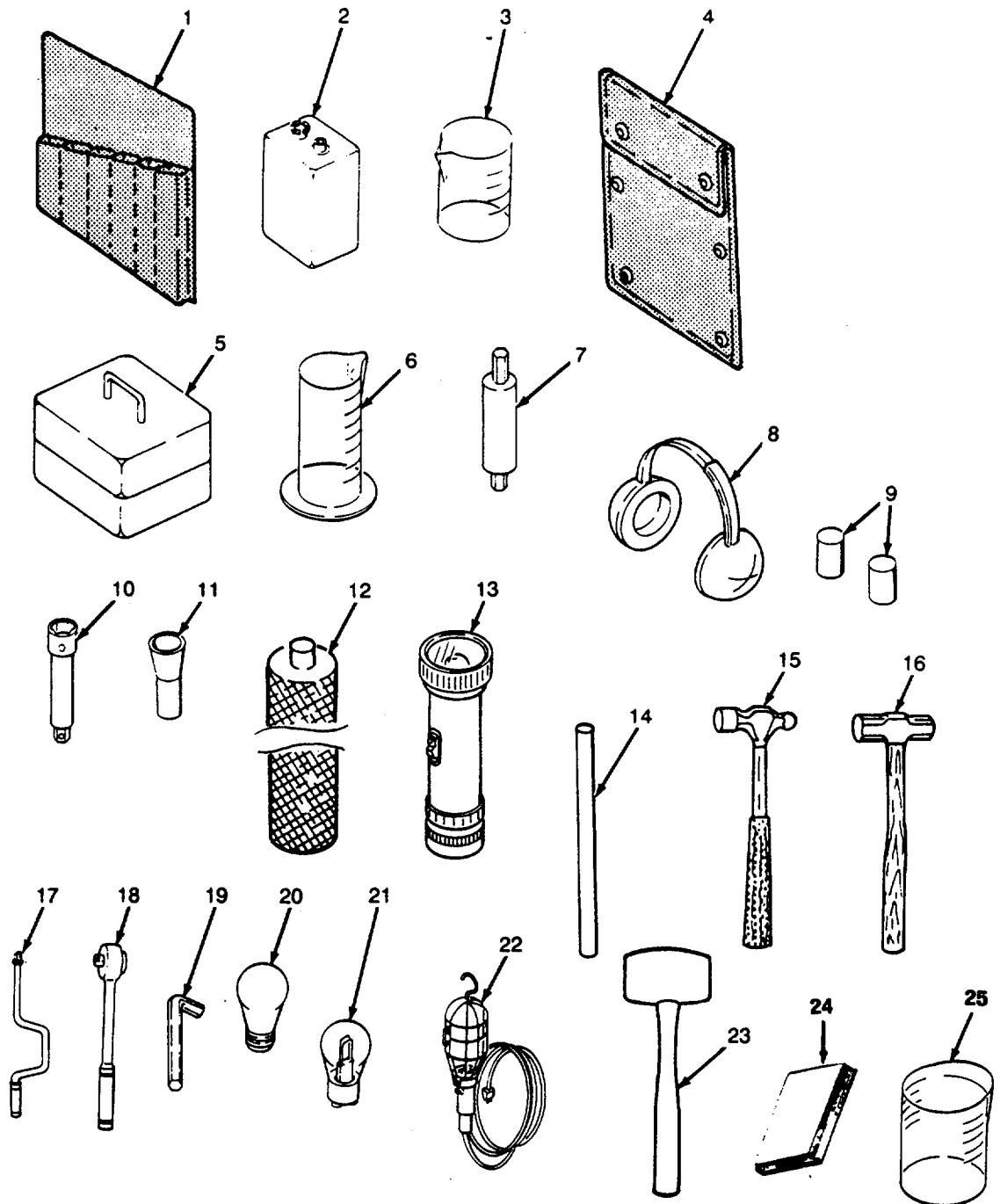

Section III. BASIC ISSUE ITEMS

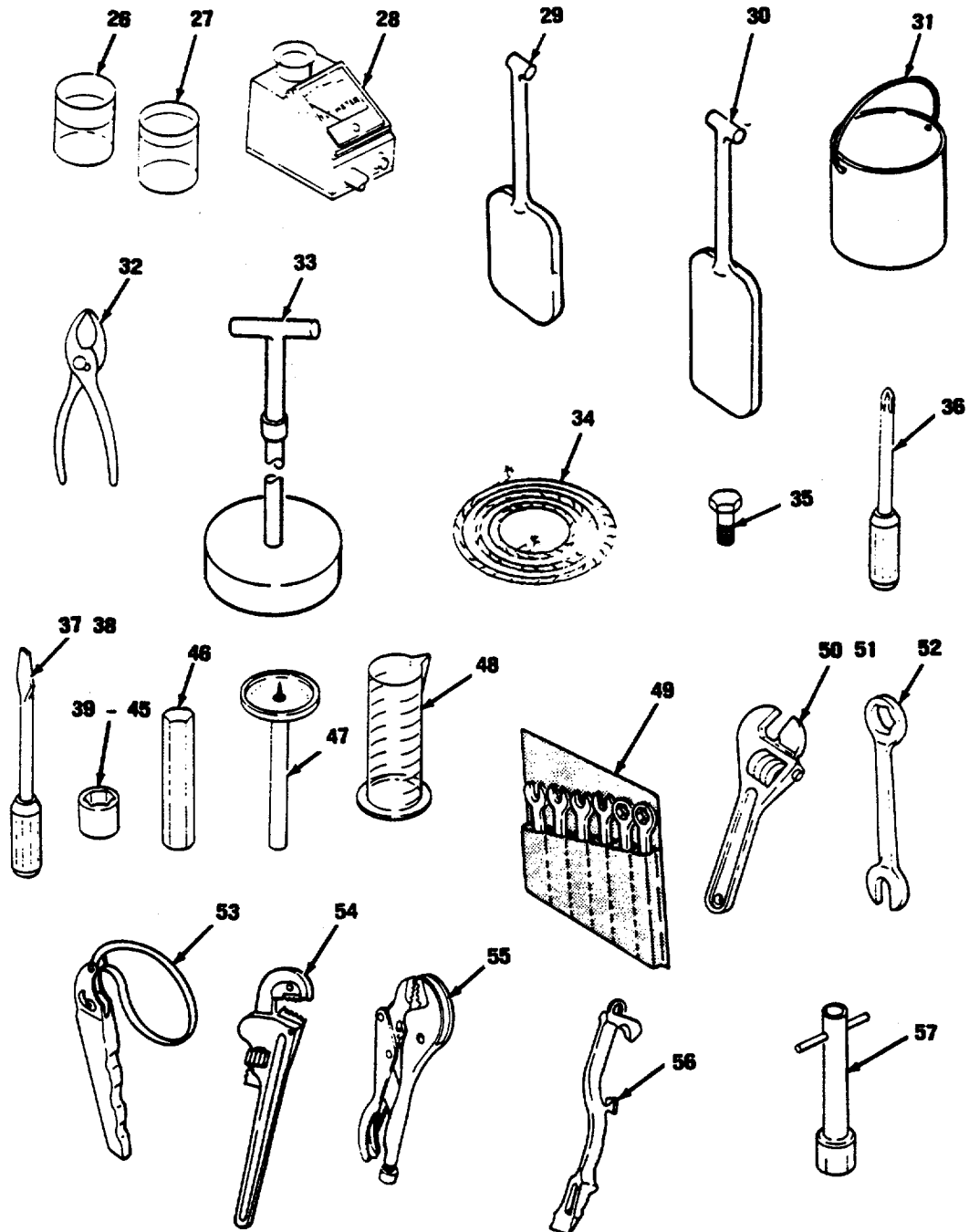

APPENDIX C
ADDITIONAL AUTHORIZATION LIST

Not Applicable

C-1/(C-2 blank)

APPENDIX D

EXPENDABLE/DURABLE SUPPLIES AND MATERIALS LIST

Section I. INTRODUCTION

D-1 SCOPE.

This appendix lists expendable/durable supplies and materials you will need to operate and maintain the Reverse Osmosis Water Purification Unit. This listing is for informational purpose only and is not authority to requisition the listed items. These items are authorized to you by CTA 50-970, Expendable/Durable Items (Except Medical, Class V, Repair Parts, and Heraldic Items), or CTA 8-100, Army Medical Department Expendable/Durable Items.

D-2. EXPLANATION OF COLUMNS.

- a. Column 1 - Item Number. This number is assigned to the entry in the listing and is referenced in the task Initial Setup instructions to identify the material; e.g., "Drycleaning solvent (Item 24, App D)."
- b. Column 2 - Category. This column identifies the lowest category of maintenance that requires the listed item:

C	-	Operator/Crew
O	-	Unit Maintenance
F	-	Direct Support Maintenance
G	-	General Support Maintenance
- c. Column 3 - National Stock Number. This is the national stock number assigned to the item; use it to request or requisition the items.
- d. Column 4 - Description. Indicates, the federal item name and, if required, a description to identify the item. The last line for each item indicates the part number followed by the Commercial And Government Entity (CAGE) Code for Manufacturer in parenthesis, if applicable.
- e. Column 5 - Unit of Measure (U/M). Indicates the measure used in performing the actual maintenance function. This measure is expressed by a two character alphabetical abbreviation (e.g., ea, in, pr). If the unit of measure differs from the rest of the issue, requisition the lowest unit of issue that will satisfy your requirements.

Section II. EXPENDABLE/DURABLE SUPPLIES AND MATERIALS LIST

Item No.	Category	National Stock Number	Description	U/M
1	F	8040-00-262-9005	Adhesive (81348) MMM-A-1617, Type II	TB
2	0		Anthracite, No. 2 (345 lbs required) (76371) 5100191000	LB
3	0	6810-00-238-8115	Calcium Hypochlorite, Technical: 3-3/4 lb Plastic Bottle	EA
4	0	6810-01-044-0315	(81348) O-C114, Type I Chlorine Test Tablets: Palin, DPD Chlorine #1: 100 Per Box; (79172) U-2510	BX
5	0	6810-01-164-3975	Citric Acid, Anhydrous, Technical: Crystalline; 3/4 Lb Plastic Bottle; (81349) MILC-52947	EA
6	F	8305-00-059-5074	Cloth, Cheesecloth	LB
7	0	6850-01-167-5318	(24064) BEP66 Coagulant Liquid, Water Treatment: 2.35 lb Plastic Bottle; (81549) MIL-I-52701	EA
8	0	7930-00-282-9699	Detergent, GP, Liq, WS, A (81349) MIL-D-16791	GL
9	0		Garnet, Course, No. 12 (170 lbs required) (76371) 5100188000	LB
10	0		Garnet, Fine No. 50 (180 lbs required) (76371) 5100189000	LB
11	0		Gravel, 1/4-inch (245 lbs required) (76371) 5100187000	LB
12	0		Grease, (70878) 35-616	LB
13	0	9150-00-190-0904	Grease, Automotive and Artillery, GAA (81349) MIL-G-10924	EA
14	0	6505-00-153-8220	Glycerin, (41946) NDC10789-1287-00	TB

Section II. EXPENDABLE/DURABLE SUPPLIES AND MATERIALS LIST (continued)

Item No.	Category	National Stock Number	Description	U/M
15	0	6810-00-087-2340	Indicator Solution, pH Wide Range 16 Oz Plastic Bottle (81349) MIL-I-52701	EA
16	0	9150-01-132-8871	Lubricant, O-Ring, Silicone Base: Moisture Resistant; - 65 °F to 4000F; 2 Oz Tube (02697) 884-2	TU
17	0		Media, Plastic (60 lbs required) (76371) 5100190000	LB
18	0	9150-01-035-5395	Oil, Lubricating, Internal Combustion Engine (81349) MIL-L-2105	GL
19	0	9150-01-152-4117	Oil, Lubricating, Internal Combustion Engine (81349) MIL-L-2104	GL
20		DELETED		
21	0	7920-00-205-1711	Rags, Wiping (58536) A-A-531	LB
22	0		Sand, Filter (230 lbs required) (76371) 5100191000	LB
23	0	5350-01-279-6314	Sanding Strip, Abrasive (77068) 8225A25	EA
24	0	6810-01-164-3941	Sodium Hexametaphosphate, Technical, 2 LB Plastic Bottle; (81349) MIL-S-51078	BT
25	F	6850-00-664-5685	Solvent, Drycleaning (81349) PD-680	GL
26	0	6850-01-163-7635	Wetting Agent; (77902) P/N 6-1572	EA
27	0	8030-00-889-3534	Tape, Antiseize, Roll (81349) MIL-T-27730	EA

Section II. EXPENDABLE/DURABLE SUPPLIES AND MATERIALS LIST (continued)

Item No.	Category	National Stock Number	Description	U/M
28	0	5970-00-147-5674	Tape, Electrical, Roll (81349) MIL-I-24391	RO
29	0		Tape Insulating (NOMEX) (97403) 1322iE8320-4)	RO
30	0	4020-00-138-7042	Twine, Ball (81349) MIL-T-713	EA

INDEX

Subject	Paragraph	Page
A		
Additional Authorization List	APPENDIX C	C-1
After Operation Preventive Maintenance Checks and Services	2-4b(2)	2-17
Air Brake	2-2	2-1
Auxiliary Equipment	2-15, 4-1	4-1
B		
Backwash of Multimedia Filter	2-10	2-69
Backwash Pump		
Location and Description	1-16b	1-3
Operation	2-10	2-69
Backwash Pump Switch	2-2c	2-2
Backwash Strainer		
Removal	3-6a	3-26
Cleaning	3-6b	3-26
Installation	2-6(13), 3-6c	3-26
Backwash Timer (Solid State)	2-20, 2-10(b)	2-16, 2-69
Backwash Valve	Table 2-1, Key 6	2-7
Backwash Water Flow Meter	Table 2-1, Key 14	2-7
Before Operation Preventive Maintenance Checks and Services	2-14b(2)	2-17
Booster Pump		
Location and Description	1-6e	1-12, 1-13
Operation	2-9g	2-61
Booster Pump Switch	2-2c	2-2
Brake System	2-1	2-2
C		
Cables, power	2-6(26)	2-50
Calcium Hypochlorite, mixing	2-6(20)	2-47
Calibration		
Chemical Feed Pump	2-9e(2)	2-59, 2-60
TDS Meter	2-15c	2-78
Canvas Covers	1-6c	1-8
Cartridge Filter		
Location and Description	1-6e	1-12
Maintenance	3-5	3-23
Cartridge Filter Gage	Table 2-1, Key 21	2-8
Cartridge Filter Tube Elements	3-5	3-23
Chemical Contaminated Areas	2-25	2-96
Chemical Feed Pump		
Adjustment	2-9e(5)	2-60
Valves	2-2j	2-13
Controls	2-2g	2-12
Location and Description.....	1-6e	1-12, 1-13
Operation	2-9	2-56
Chemical Feed Pump Switch	2-2c	2-2

INDEX Continued

Subject	Paragraph	Page
C - (cont.)		
Chlorine, mixing	2-6(20)	2-47
Choosing the Site	2-5	2-30
Circuit Breakers	2-2d	2-2
Citric Acid, mixing	2-6(23)	2-48
Cold Weather Operations	2-20	2-93
Color Comparator Kit	2-2n	2-15
Components of End Item List	APPENDIX B	B-1
Control Box Assembly	2-2c	2-2
Controls and Indicators	Section I, Chapter 2	2-1
Control Panel	2-2b	2-2
D		
Distribution Pump		
Location and Description	1-6b	1-3
Operation	2-9j(13)	2-69
Distribution Pump Switch	2-2c	2-2
Drain Valves	2-2i	2-13
During Operation Preventive Maintenance Checks and Services	2-4b(2)	2-17
Dusty and Sandy Areas	2-22	2-96
E		
EIR	1-4	1-1
Electrical Plug, Trailer	2-1	2-1
Emergency Shutdown Procedures	2-8a, 2-9a(3)	2-55, 2-56
End Cap Removal	3-4c	3-17
Equipment Characteristics, Capabilities and Features	1-5	1-2
Equipment Data	1-7	1-16
Expendable Supplies and Materials List	APPENDIX D	D-1
F		
Float	1-6b	1-4
Fording	2-17	2-91
G		
Gages		
Location and Description	2-2b	2-2
Normal and Trouble Point Reading	2-9j(8)	2-67
Gate Valves	2-2h	2-12
Generator Set	1-6c	1-8
Glossary	Glossary	Glossary 1
Ground Rod		
Location and Description	1-6c	1-8
Installation	2-6(25)	2-49

INDEX Continued

Subject	Paragraph	Page
H		
Hand Receipt	1-3	1-1
High Pressure Relief Valve	2-8a	2-55
Hose Installation		
Backwash	2-6(14)	2-46
Product Water	2-6(15)	2-47
Raw Water	2-6(12)	2-45
Vent Vessels	2-6(16)	2-48
Waste Water	2-6(16)	2-48
Hot Weather Operations	2-21	2-95
I		
Indicator Lamps, Maintenance	3-9	3-28
Initial Adjustment and Checks	2-7	2-50
Installation		
Cartridge Filter Tube Elements	3-5	3-23
R.O. Elements	3-4h	3-20
Rupture Disc	3-7	3-27
J		
Jog Switch	2-2	2-2
Junction Box	1-6c	1-9
K		
Not Applicable		
L		
Lamps, Maintenance	3-9	3-28
Leveling Jacks	2-1b	2-2
Location and Description of Major Components	1-6	1-2
Low Pressure Lamp.....	Table 2-1, Key 24	2-8
Lubrication Instructions	3-1	3-1
Lunette	1-6f	1-14
M		
Maintenance of Auxiliary Equipment	3-8, 4-1	3-28, 4-1
Maintenance Forms and Records	1-2	1-1
Maintenance Procedures		
Backwash Pump Strainer	3-6	3-26
Cartridge Filter	3-5	3-23
Indicator Lamps	3-9	3-29
Panel Light	3-10	3-30
R.O. Elements	3-4	3-16
Rupture Disc	3-7	3-27

INDEX Continued

Subject	Paragraph	Page
M - (cont.)		
TDS Meter	3-8	3-28
Monthly Operation Preventive Maintenance Checks and Services	2-4b(2)	2-17
Multimedia Filter		
Backwash Timer	2-10b	2-69
Location and Description	1-6e	1-12
Multimedia Filter Gage		
Location	2-2b	2-2
Normal and Trouble Point Reading	2-9(8)	2-67
N		
Normal Shutdown Procedures	2-14	2-76
Nuclear Biological, and Chemical Contaminated Areas	2-25	2-96
O		
Oil Level		
Chemical Feed Pump	3-1	3-1
R.O. Pump	3-1	3-1
Operating Procedures	2-9	2-56
Operation of Auxiliary Equipment	2-15	2-78
Operations Under Unusual Conditions	2-17 to 2-25	2-91 to 2-96
Operator's Controls and Indicators	2-1 to 2-2	2-1 to 2-16
P		
Panel Light		
Location	2-2b, 2-2c	2-2
Maintenance	3-10	3-30
Piping Identification	1-8	1-18
Polymer, mixing	2-21(19)	2-47
Posttreatment Kits	2-25	2-96
Power Cables	2-21(26)	2-50
Preparation for Movement	2-16	2-80
Pressure Relief Valve, High	2-8a	2-55
Preventive Maintenance Checks and Service	2-3, 2-4	2-17
Principles of Operation	1-9	1-19
Priming Valves, Chemical Feed Pump		
Location and Description	1-6e	1-12, 1-13
Operation	2-2j	2-13
Product Water Flow Meter	2-2b	2-2
Pulse Dampener		
Location and Description	1-6e	1-12

Q

Not Applicable

INDEX Continued

Subject	Paragraph	Page
R		
Rainy and Damp Areas	2-23	2-96
Raw Water Flow Gage		
Location and Description	2-2b	2-2
Normal and Trouble Point Reading	2-9j(8)	2-67
Raw Water Pumps		
Location and Description	1-6b	1-3
Operation	2-9b-c	2-57 to 2-58
Raw Water Pump Switch	2-9b	2-57
Regulate Product Flow Valve		
Location and Description	2-2b	2-2
Operation	2-7e, 2-29j(5)-(6)	2-52,2-66
References	APPENDIX A	A-1
Reporting Equipment Improvement Recommendations	1-4	1-1
Reset Switch	2-2c	2-2
Reset Locked Air Brakes	2-18	2-91
R.O. Elements		
Cleaning	2-12	2-72
Maintenance	3-4	3-16
Rinse	2-12	2-72
R.O. Element Puller	3-4d	3-18
R.O. Element Cleaning Switch	2-2c	2-2
Operation	2-13a(10)	2-74
R.O. Pressure P.S.I Meter	2-2b	2-2
R.O. Pressure Vessels		
Location	1-6e	1-12
Maintenance	3-4	3-16
R.O. Pump		
Location and Description	1-6e	1-12
Operation	2-9h	2-62
R.O. Pump High Pressure Lamp	2-9a(3)	2-56
R.O. Pump Low Pressure Lamp	2-9a(3)	2-56
R.O. Pump Reset Switch	2-9h(2)	2-62
R.O. Vessels Gage		
Location and Description	2-2b	2-2
Normal and Trouble Point Reading	2-9j(8)	2-67
Rupture Disc Assembly		
Location and Description	2-8c	2-55
Maintenance	3-7	3-27
S		
Safety Valves	2-8	2-55
Saltwater Areas	2-24	2-96
Scope	1-1	1-1
Shutdown Procedures	2-14	2-76
Site Selection	2-5	2-30
Sodium Hex, mixing	2-6(22)	2-48

INDEX Continued

Subject	Paragraph	Page
S - (cont.)		
Storage Boxes	2-6b(4), Append. B	B-2
.....		to B-5
Switches, Location and Function	2-2b	2-2
Swivel Assembly	2-lb	2-2

T

Tanks, Water		
Installation	2-6(11)	2-41
Maintenance	3-8	3-28
TDS Meter		
Location and Description	2-21	2-14
Operation.....	2-15c	2-78
Calibration (Maintenance)	2-15c, 3-9	2-78, 3-29
Technical Principles of Operation	1-9	1-19
Trailer Lights	2-1	2-1
Troubleshooting Procedures	3-2	3-1
Turbidity Tube	2-2m	2-14

U

Not Applicable

V

Valves		
Backwash	Table 2-1, Key 6	2-7
Chemical Feed Pump	2-2j	2-13
Drain	2-2i	2-13
Gate	2-2h	2-12
Product Water Flow, Regulate	Table 2-1, Key 17	2-7
Vent Vessels	2-2e	2-11
Vent Cartridge Filter Valve	Table 2-1, Key 3	2-7
Vent Multimeter Filter Valve	Table 2-1, Key 5	2-7
Vent Product Water Valve	2-2f	2-11
Vent Pulse Dampener Valve	Table 2-1, Key 4	2-7
Vent Vessels Valve		
Location and Description	2-2e	2-11

W

Water Processing and Chemicals	1-9	1-19
Water Tanks		
Installation	2-6(12)	2-42
Maintenance	3-8	3-28
Weekly Operation Preventive Maintenance Checks and Services	2-6b(2)	2-17

INDEX Continued

Subject		Paragraph	Page
	X		
Not Applicable			
	Y		
Not Applicable			
	Z		
Not Applicable			

Index-7/(Index-8 blank)

By Order of the Secretaries of the Army, Air Force and Navy (Including the Marine Corps):

Official:

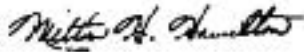

MILTON H. HAMILTON
Administrative Assistant to the
Secretary of the Army
02137

GORDON R. SULLIVAN
General, United States Army
Chief of Staff

Official:

CHARLES C. McDONALD
General, USAF
Commander, Air Force Logistics Command

MERRILL A. McPEAK
General, USAF
Chief of Staff

H. E. REESE
Deputy for Support
Marine Corps Research, Development and
Acquisition Command

DAVID E. BOTTORFF
Rear Admiral, CEC, US Navy
Commander
Navy Facilities Engineering Command

DISTRIBUTION:

To be distributed in accordance with DA Form 12-25E, (qty rqr block no. 4486).

These are the instructions for sending an electronic 2028

The following format must be used if submitting an electronic 2028. The subject line must be exactly the same and all fields must be included; however only the following fields are mandatory: 1, 3, 4, 5, 6, 7, 8, 9, 10, 13, 15, 16, 17, and 27.

From: "Whomever" <whomever@avma27.army.mil>

To: mpmt%avma28@st-louis-emh7.army.mil

Subject: DA Form 2028

1. **From:** Joe Smith
2. Unit: home
3. **Address:** 4300 Park
4. **City:** Hometown
5. **St:** MO
6. **Zip:** 77777
7. **Date Sent:** 19-OCT-93
8. **Pub no:** 55-2840-229-23
9. **Pub Title:** TM
10. **Publication Date:** 04-JUL-85
11. Change Number: 7
12. Submitter Rank: MSG
13. **Submitter FName:** Joe
14. Submitter MName: T
15. **Submitter LName:** Smith
16. **Submitter Phone:** 123-123-1234
17. **Problem: 1**
18. Page: 2
19. Paragraph: 3
20. Line: 4
21. NSN: 5
22. Reference: 6
23. Figure: 7
24. Table: 8
25. Item: 9
26. Total: 123
27. **Text:**

This is the text for the problem below line 27.

RECOMMENDED CHANGES TO EQUIPMENT TECHNICAL PUBLICATIONS

 <p style="font-size: small; margin: 0;"><i>THEN...JOT DOWN THE DOPE ABOUT IT ON THIS FORM. CAREFULLY TEAR IT OUT, FOLD IT AND DROP IT IN THE MAIL.</i></p>		SOMETHING WRONG WITH PUBLICATION	
		FROM: (PRINT YOUR UNIT'S COMPLETE ADDRESS)	
		DATE SENT	
PUBLICATION NUMBER		PUBLICATION DATE	PUBLICATION TITLE
BE EXACT PIN-POINT WHERE IT IS			
PAGE NO.	PARA-GRAPH	FIGURE NO.	TABLE NO.
IN THIS SPACE, TELL WHAT IS WRONG AND WHAT SHOULD BE DONE ABOUT IT.			
PRINTED NAME, GRADE OR TITLE AND TELEPHONE NUMBER			SIGN HERE

The Metric System and Equivalents

Linear Measure

1 centimeter = 10 millimeters = .39 inch
 1 decimeter = 10 centimeters = 3.94 inches
 1 meter = 10 decimeters = 39.37 inches
 1 dekameter = 10 meters = 32.8 feet
 1 hectometer = 10 dekameters = 328.08 feet
 1 kilometer = 10 hectometers = 3,280.8 feet

Weights

1 centigram = 10 milligrams = .15 grain
 1 decigram = 10 centigrams = 1.54 grains
 1 gram = 10 decigrams = .035 ounce
 1 decagram = 10 grams = .35 ounce
 1 hectogram = 10 decagrams = 3.52 ounces
 1 kilogram = 10 hectograms = 2.2 pounds
 1 quintal = 100 kilograms = 220.46 pounds
 1 metric ton = 10 quintals = 1.1 short tons

Liquid Measure

1 centiliter = 10 milliliters = .34 fl. ounce
 1 deciliter = 10 centiliters = 3.38 fl. ounces
 1 liter = 10 deciliters = 33.81 fl. ounces
 1 dekaliter = 10 liters = 2.64 gallons
 1 hectoliter = 10 dekaliters = 26.42 gallons
 1 kiloliter = 10 hectoliters = 264.18 gallons

Square Measure

1 sq. centimeter = 100 sq. millimeters = .155 sq. inch
 1 sq. decimeter = 100 sq. centimeters = 15.5 sq. inches
 1 sq. meter (centare) = 100 sq. decimeters = 10.76 sq. feet
 1 sq. dekameter (are) = 100 sq. meters = 1,076.4 sq. feet
 1 sq. hectometer (hectare) = 100 sq. dekameters = 2.47 acres
 1 sq. kilometer = 100 sq. hectometers = .386 sq. mile

Cubic Measure

1 cu. centimeter = 1000 cu. millimeters = .06 cu. inch
 1 cu. decimeter = 1000 cu. centimeters = 61.02 cu. inches
 1 cu. meter = 1000 cu. decimeters = 35.31 cu. feet

Approximate Conversion Factors

To change	To	Multiply by	To change	To	Multiply by
inches	centimeters	2.540	ounce-inches	Newton-meters	.007062
feet	meters	.305	centimeters	inches	.394
yards	meters	.914	meters	feet	3.280
miles	kilometers	1.609	meters	yards	1.094
square inches	square centimeters	6.451	kilometers	miles	.621
square feet	square meters	.093	square centimeters	square inches	.155
square yards	square meters	.836	square meters	square feet	10.764
square miles	square kilometers	2.590	square meters	square yards	1.196
acres	square hectometers	.405	square kilometers	square miles	.386
cubic feet	cubic meters	.028	square hectometers	acres	2.471
cubic yards	cubic meters	.765	cubic meters	cubic feet	35.315
fluid ounces	milliliters	29.573	cubic meters	cubic yards	1.308
pints	liters	.473	milliliters	fluid ounces	.034
quarts	liters	.946	liters	pints	2.113
gallons	liters	3.785	liters	quarts	1.057
ounces	grams	28.349	liters	gallons	.264
pounds	kilograms	.454	grams	ounces	.035
short tons	metric tons	.907	kilograms	pounds	2.205
pound-feet	Newton-meters	1.356	metric tons	short tons	1.102
pound-inches	Newton-meters	.11296			

Temperature (Exact)

°F	Fahrenheit temperature	5/9 (after subtracting 32)	Celsius temperature	°C
----	---------------------------	-------------------------------	------------------------	----

PIN: 070221-002